



RAIMONDI

SINCE 1974 INNOVATIONS FOR
THE TILE SETTING PROFESSIONAL

OFFICIAL DISTRIBUTOR IN BALTIC STATES

Mproducts, UAB
Address: Verkiu str. 36, Vilnius,
LT-09109 Lithuania
Mob.: +370 650 19699, +370 656 19670
E-mail.: info@mproducts.lt



CATALOG 2019A



**ITALIAN
INNOVATION
AND TECHNOLOGY
FOR THE TILE
SETTING
PROFESSIONALS**

Italy is known to be the cradle of ceramic tiles and it is still one of the most important production areas worldwide especially in terms of product innovation.

Innovative ceramic tiles inevitably lead to innovative tile installation processes since the two are physiologically connected together.

Raimondi, since its founding (1974, Modena) focused on the tools for the tile installation business and stood out in the industry thanks to its strong innovation capacity (which often resulted in being ahead of its time), its technological solutions as well as for the highest quality of its product, elements of which have led the company to become a world leader in the industry.

All this without giving up total control and management of the product, from development to shipment, from our facilities in Modena, Italy, where Raimondi products are still designed and assembled.





PORCELAIN DIAMOND BLADE COMES NOW STANDARD FOR ALL ZOE AND SMS WET SAWS MODELS

PAGE 8-10

To meet the needs of end users, all ZOE and SMS bridge wet saws models are now supplied with Ø 350 mm (14") diamond blade specifically designed for cutting porcelain tiles.



MEGATITINA

PAGE 31

Single-disc/head machine ideal both for scratching porcelain surfaces (but also marble, resin, concrete, etc.) as well as for sanding and smoothing irregular surfaces. The power (4 hp for 400V three-phase version, 3.4 hp for 230V single-phase version) combined with the diameter of the tools holder disc (Ø 280 and/or 380 mm) and the adjustable weight (from 67 to 73 kg thanks to the ballast which can be located in two positions or completely removed) confers the machine an impressive effectiveness and flexibility. Designed to work even in contact to the wall. The tools holder disc is designed for both Frankfurt attachment tools (maximum 3) and with 12x40 mm diamond segments (maximum 6).



FLOW / SLANT RIDGE NOTCHED TROWEL 36x13 cm (14 3/16"x5 1/8")

PAGE 44

The flow / slant ridge trowel allows to obtain a level of coverage unachievable with traditional teeth. Independent external tests have proven that the use of flow / slant ridge trowel (using back-buttering technique) allows to reach 95/96% coverage. This is ideal for any kind of tiles and fundamental for large format tiles / panels (i.e.: 3x1m; 10'x3.3'). Even more if thin (3-5 mm; 1/8"-3/16"). Now this special trowel is available in the 36x13 cm (14 3/16"x5 1/8") size which, if compared to the traditional 28x13 cm (11"x4 3/4"), increases the amount of adhesive set for each pass of 30%.



RLS: TILES CHIPPING (AND SCRATCHING) PREVENTING PLATFORM AND MULTI-SIZE SPACER

PAGE 53

The new (patented) anti-chipping and anti-scratch platform to be used in combination with the well-known RLS leveling system is designed to avoid potential accidental damage during installation of tiles characterized by a particularly delicate top finishing. The platform performs two functions at the same time. Anti-chipping: prevents the stems of the RLS clip to touch the edge of the tile during wedge insertion. Anti-scratch: prevents the wedge to touch the tile. Furthermore, the platform can also be used as a removable and reusable multi-size-spacer (1,5, 2 and 3 mm; 1/16", 3/32", 1/8").



(HAND-FREE) SCRATCH-PREVENTING WASHER FOR RLS VITE

PAGE 54

The highly innovative washer for RLS VITE (patented) had been developed to prevent to scratch tiles characterized by a particularly delicate top finishing as well as to prevent the tiles to eventually move when tightening the RLS VITE Cap. The washer is designed to be connected to the RLS VITE cap for the maximum ease of use. It features an exclusive soft rubber ring that once it gets in contact with the tiles prevents the washer to rotate when tightening the cap. This on the one hand avoid any risk of scratching the tiles, on the other allows to tighten the cap without having to hold the washer with your hand.



ROTOCUNEO

PAGE 54

Kit of 3 wedges: two spiral-shaped and one traditional. The spiral-shape allows to adjust the thickness of the joint (from 2 to 10 mm; 3/32"-3/8") simply by rotating the wedge. Performance which is not achievable by a traditional wedge. This characteristic is particularly appreciated for the installation of large format tiles (i.e.: 3x1m; 10'x3.3') since the rotation of the wedge allows to put and maintain the tile at the desired height and so obtaining the perfect level/plumb. When the installation is complete, the removal of ROTOCUNEO occurs by rotating it in the opposite direction to that of the insertion. This removal methodology is extremely delicate and preserves the edges of the tile intact.



POWER-RAIZOR AND WATER CUT & DUST SUPPRESSION DEVICES

PAGE 59

POWER-RAIZOR is the cutting unit with grinder for RAIZOR. Its variable angle (45/90/180°) allows to perform 45° angle cuts ("jolly"/mitering), 90° (straight cut), 1/2 bullnose shape and kerf. POWER-RAIZOR also features plunge cut to adjust the depth of cut so to perform cuts in the middle of the slab (square and rectangular holes). It comes standard configured for dry cut and provided with clutch hose for dust extraction. However, it can be equipped with a special kit to water cooling the blades which, while improving quality and speed of cut, it completely suppresses even the smallest dust particles. As an alternative another kit for dramatically increasing dust suppression while dry-cutting is available.



BM 180 PLUS. ADJUSTABLE WIDTH (100-150 CM / 3.3'- 5') TABLE FOR LARGE FORMAT TILES

PAGE 61

BM 180 PLUS table is designed to be the perfect workstation for large format tiles up to 160 cm (5.3') wide. In fact, with few simple movements, the width of the worktop can vary from a minimum of 100 cm (3.3') to a maximum of 150 cm (5'). Maximum stability and sturdiness are guarantee at any chosen width. The length of the table is 180 cm (5.9'). Connect two tables together to obtain a worktop of 360 cm (11.8') in length and width of up to 150 cm (5'). BM 180 PLUS is equipped with folding legs for maximum ease of transport and storage.



TILE-SUPPORT CYLINDERS FOR BM 180

PAGE 61

Once mounted on the BM180 table (both BM180 mklI and BM180 plus) this kit of 20 supports keeps the slab lifted with respect to the bench aluminum profiles, always guaranteeing a stable support. The lifted position of the tile allows to perform cuts with angle grinders in every direction without having to worry about the risk of damaging the underlying worktop with the diamond blade. The modularity of the supports allows to arrange them in the best way to combine stability and support to the slab even for the most complex cuts, such as square and rectangular holes. In plastic material and extremely resistant, studied to last for a long time and to be reusable virtually forever.



SIDE PROFILES FOR INCISION AND CUT (124 AND 164 cm; 4' AND 5.4') AND SIDE EXTENSION 90 cm (35 1/2") FOR BM 180

PAGE 61

Two new accessories for the BM180 table. The side profile connects to the short side of the table offering a continuous support for score & cut the short side of the tile (i.e.: cut 120 cm side of a 120x240 cm tile). Available in two lengths: 124 cm and 164 cm (4' and 5.4'). Therefore, suitable even for the largest tiles. We recommend the use of the 164 cm (5.4') version only with BM180 PLUS. Version 124 cm (4') fits on both BM180 mklI and BM180 PLUS. The 90 cm (35 1/2") side extension (compatible only with BM180 mklI) connected to a single BM180 mklI creates a worktop long 270 cm (106"). This make it unnecessary to use two full tables for slabs below this length.



TIP-TOP. FACE-UP MITER-CLAMPING-DEVICE FOR TILES AND STONES OF ANY LENGHT

PAGE 62

Face-up miter clamping devices designed to work with fully visibility of the corner on tiles and stones of any length. Allow the user to see the corner with no need to bend. Independent double micrometric adjustments (vertical - up and down / horizontal - back and forward) allows to easy create the perfect corner. No tile length limits make it perfect for large format porcelain tiles as well. As a general guideline we recommend to use a pair (1 kit) on tiles or stones up to 200 cm (6.6") length. For longer files just add additional units. Slider adjustment to accommodate laminated edges from 30 to 300 mm (1 3/16" - 12").

BRIDGE AND TROLLEY SAW MACHINES



PAGE 6

COMPACT SAW MACHINES



PAGE 14

SAW MACHINES AND PROFILING MACHINES FOR SPECIAL JOBS



PAGE 16

DIAMOND WHEELS AND BLADES



PAGE 23

TOOLS FOR FAÇADE



PAGE 24

HOLE CUTTING MACHINES AND BITS MIXERS



PAGE 25

MIXERS



PAGE 27

VIBRATORS AND ELECTRICAL BARS



PAGE 29

FLOOR PREPARATION MACHINES



PAGE 31

SPONGE MACHINES



PAGE 38

WASH BASINS, SPONGE FLOATS AND SPONGES



PAGE 39

GROUTING TOOLS



PAGE 42

ADHESIVE TOOLS

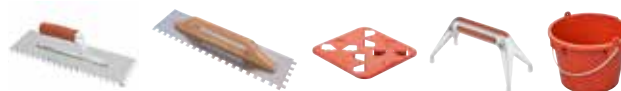

PAGE 44

TOOLS



PAGE 49

R.L.S. - RAIMONDI LEVELLING SYSTEM



PAGE 52

SPACERS, EXTENSION JOINTS AND PROFILES



PAGE 54

MANUAL TILE CUTTERS



PAGE 58

EQUIPMENT FOR BIG TILES/SLABS



PAGE 59



MAX LENGTH OF CUT

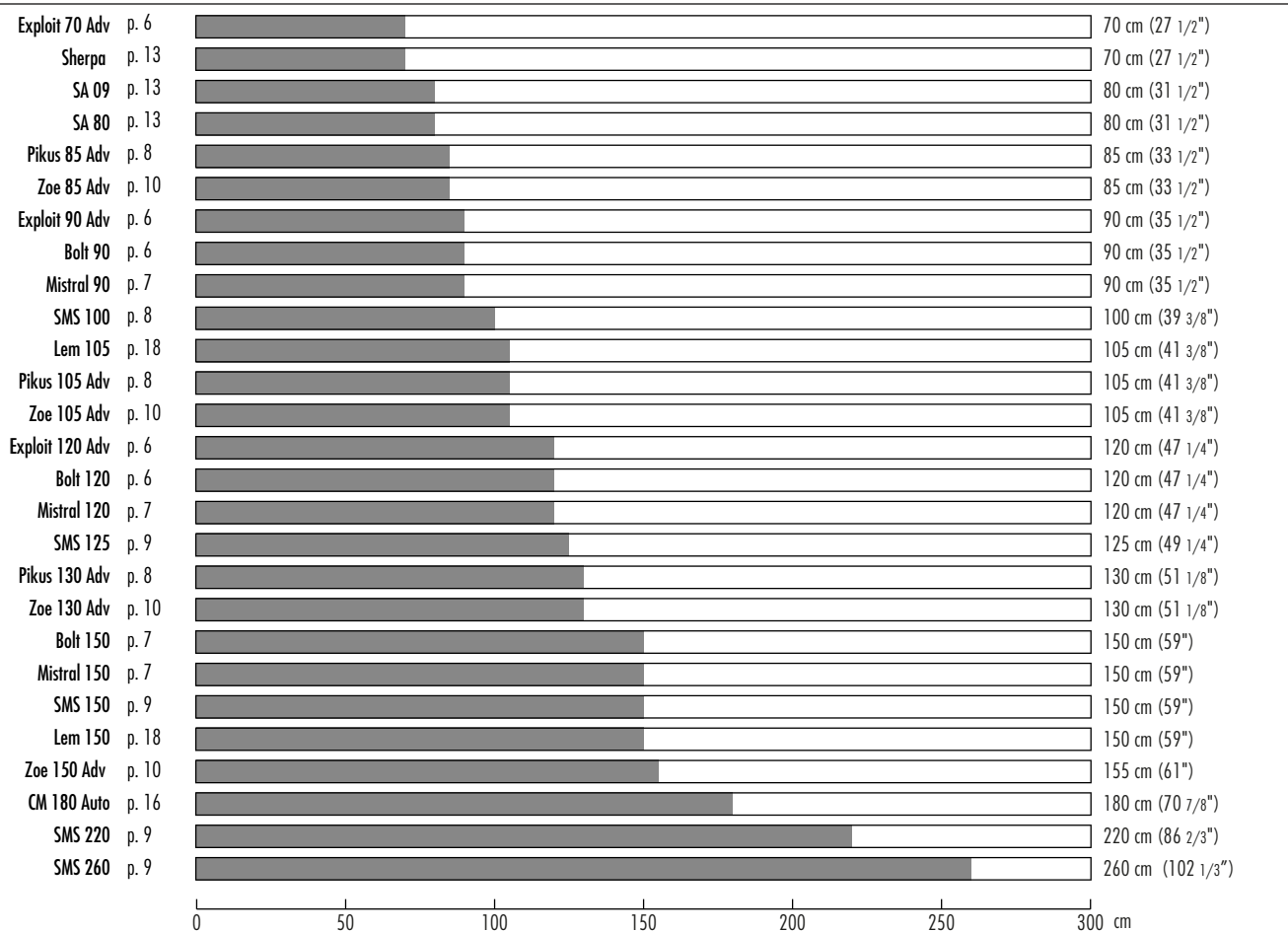

MAX DIAGONAL CUT (TILE SIZE)

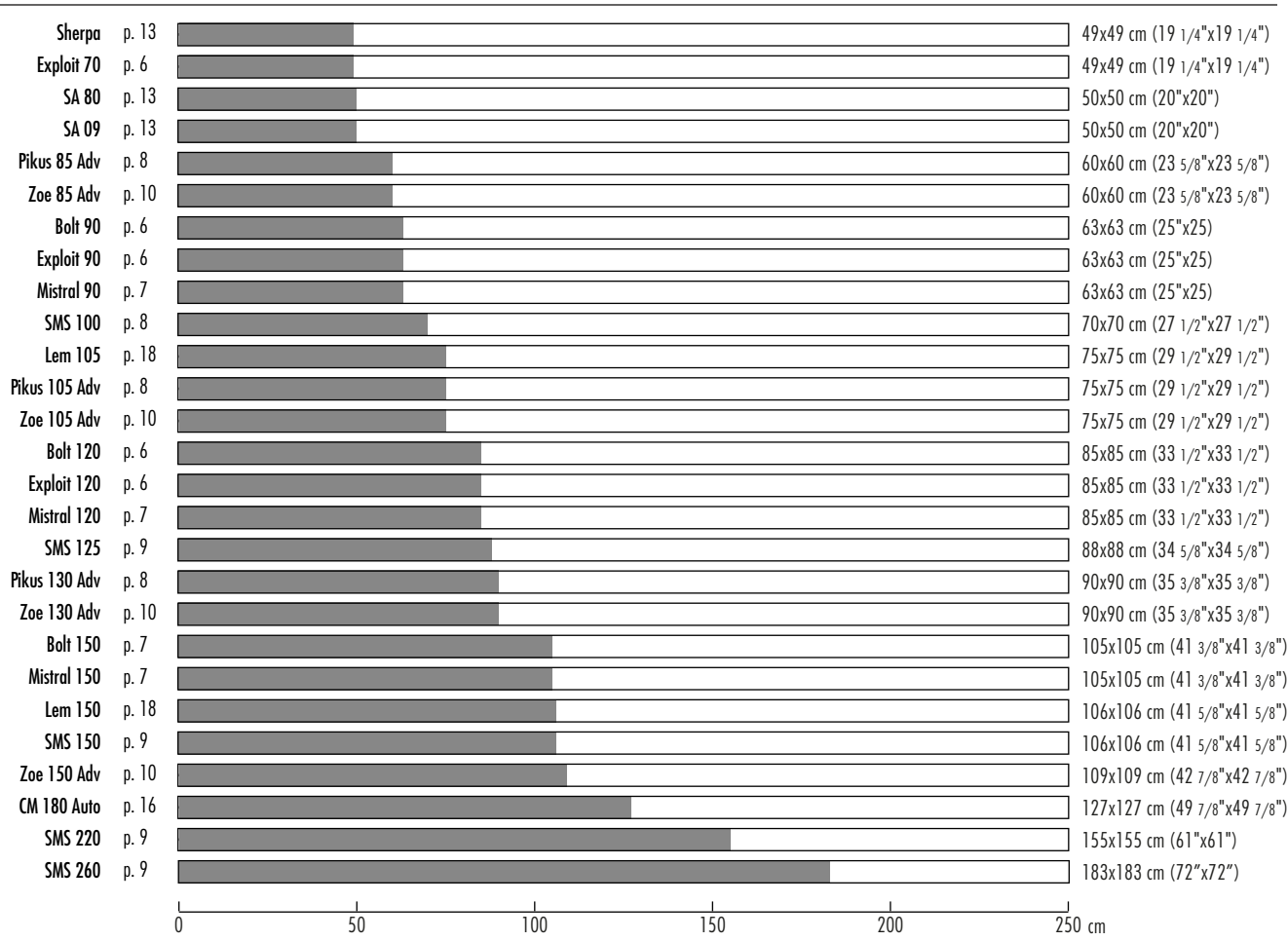

MAX THICKNESS OF CUT (SINGLE PASS)

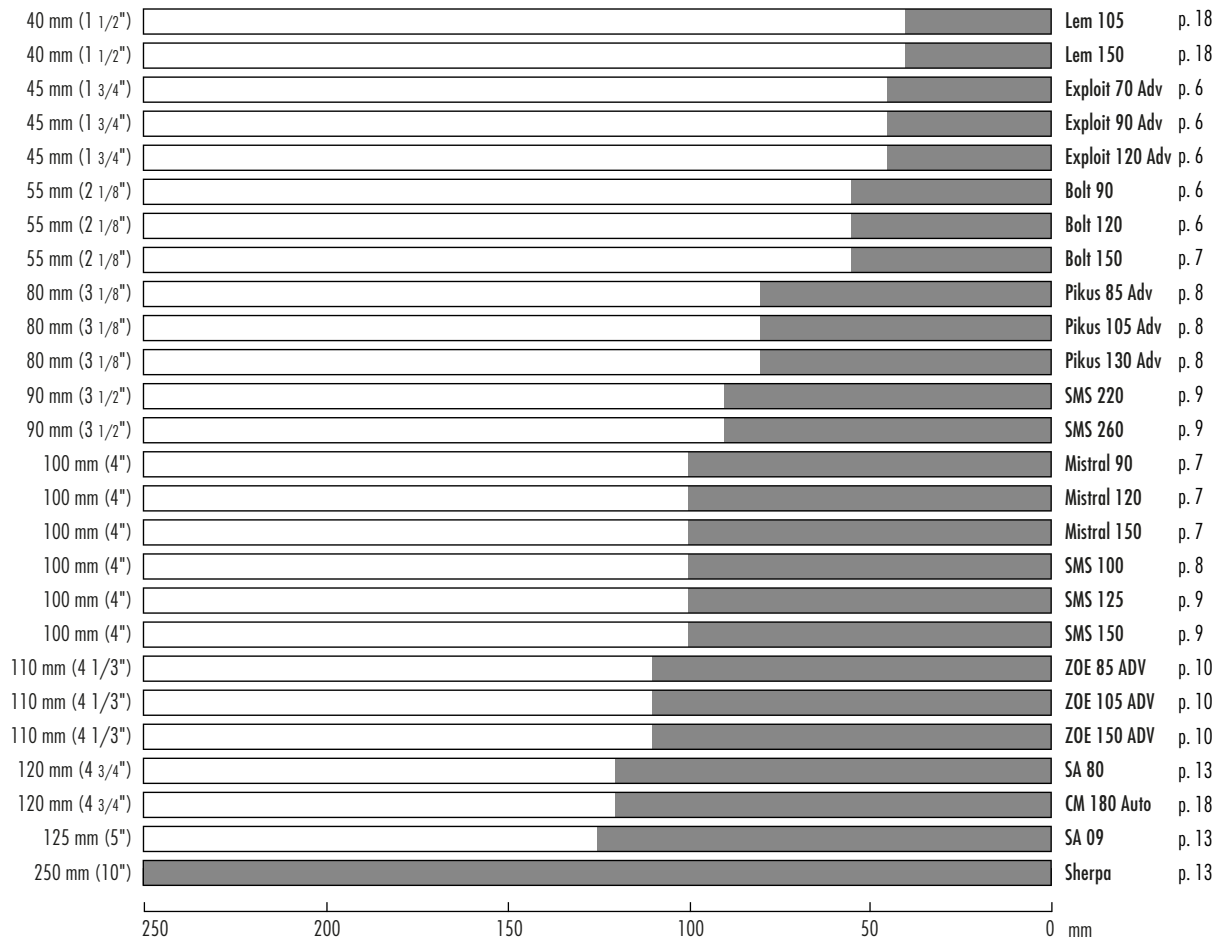

MAX THICKNESS OF CUT (DOUBLE PASS)

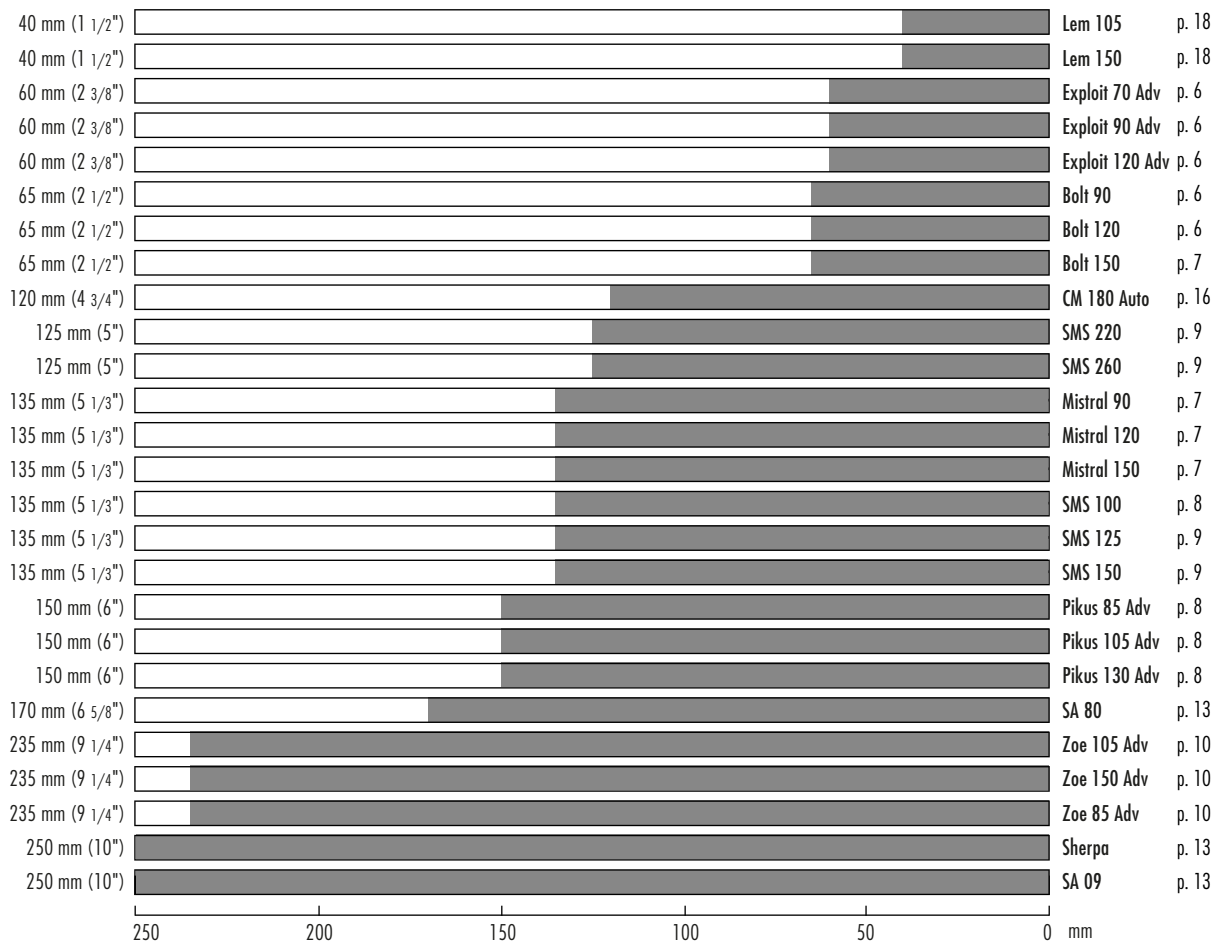

EXPLOIT 70

1



1	393N 070EU	8024648089366	1	Exploit 70 with blade Ø 200 mm (8") continuous rim	Single-phase	230 V 50 Hz	0,65	+ "1"
1	393N 070BR	8024648091017	1	Exploit 70 with blade Ø 200 mm (8") continuous rim	Single-phase	230 V 60 Hz	0,65	+ "1"
1	393N 070US	8024648089380	1	Exploit 70 with blade Ø 200 mm (8") continuous rim	Single-phase	110 V 60 Hz	0,65	+ "1"
1	393N 070GB	8024648089373	1	Exploit 70 with blade Ø 200 mm (8") continuous rim	Single-phase	110 V 50 Hz	0,65	+ "1"

CUTTING SPECIFICATIONS AND MACHINE DIMENSIONS/WEIGHT

Model													
EXPLOIT 70	200 mm	8"	45 mm	1 3/4"	25 mm	1"	70 cm	∞	49x49 cm	100x56x h50 cm	34 Kg	101x57x h41 cm	36 Kg
	180 mm	7"	35 mm	1 3/8"	-	-	27 1/2"		19 1/2" x 19 1/2"	39 3/8" x 22" x h 19 5/8"	75 lbs	39 3/4" x 22 1/2" x h 16 1/8"	79.4 lbs

TECHNICAL CHARACTERISTICS

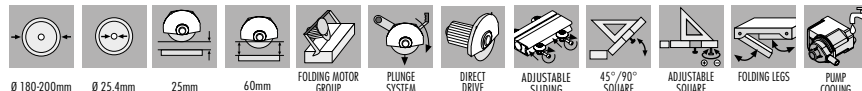

AVAILABLE BLADES

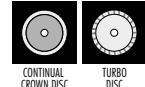

EXPLOIT 90

2



2	393N 090EU	8024648089397	1	Exploit 90 with blade Ø 200 mm (8") continuous rim	Single-phase	230 V 50 Hz	0,65	#2 3/8" 1"
2	393N 090BR	8024648091031	1	Exploit 90 with blade Ø 200 mm (8") continuous rim	Single-phase	230 V 60 Hz	0,65	#2 3/8" 1"
2	393N 090US	8024648089410	1	Exploit 90 with blade Ø 200 mm (8") continuous rim	Single-phase	110 V 60 Hz	0,65	#2 3/8" 1"
2	393N 090GB	8024648089403	1	Exploit 90 with blade Ø 200 mm (8") continuous rim	Single-phase	110 V 50 Hz	0,65	#2 3/8" 1"

CUTTING SPECIFICATIONS AND MACHINE DIMENSIONS/WEIGHT

Model													
EXPLOIT 90	200 mm	8"	45 mm	1 3/4"	25 mm	1"	90 cm	∞	63x63 cm	120x56x h50 cm	35 Kg	130x58 h55 cm	45 Kg
	180 mm	7"	35 mm	1 3/8"	-	-	35 1/2"		25" x 25"	47 1/4" x 22" x h 19 5/8"	77.2 lbs	51 1/8" x 23" x h 21 5/8"	99.2 lbs

TECHNICAL CHARACTERISTICS

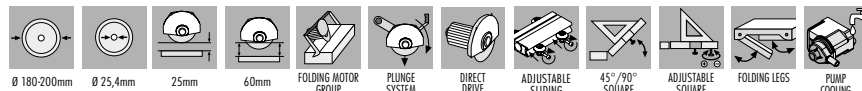

AVAILABLE BLADES

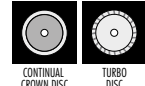

EXPLOIT 120

3



3	393N 120EU	8024648095664	1	Exploit 120 with blade Ø 200 mm (8") continuous rim	Single-phase	230 V 50 Hz	0,9	#3 1/2" 1"
3	393N 120BR	8024648095893	1	Exploit 120 with blade Ø 200 mm (8") continuous rim	Single-phase	230 V 60 Hz	0,9	#3 1/2" 1"
3	393N 120US	8024648095701	1	Exploit 120 with blade Ø 200 mm (8") continuous rim	Single-phase	110 V 60 Hz	0,9	#3 1/2" 1"
3	393N 120GB	8024648095909	1	Exploit 120 with blade Ø 200 mm (8") continuous rim	Single-phase	110 V 50 Hz	0,9	#3 1/2" 1"

CUTTING SPECIFICATIONS AND MACHINE DIMENSIONS/WEIGHT

Model													
EXPLOIT 120	200 mm	8"	45 mm	1 3/4"	25 mm	1"	120 cm	∞	85x85 cm	155x70xh 50 cm	46 Kg	165x65xh 55 cm	62 Kg
	180 mm	7"	35 mm	1 3/8"	-	-	47 1/4"		33 1/2" x 33 1/2"	61" x 27" x h 20"	101.4 lbs	65" x 25 1/2" x h 21 5/8"	136.7 lbs

TECHNICAL CHARACTERISTICS

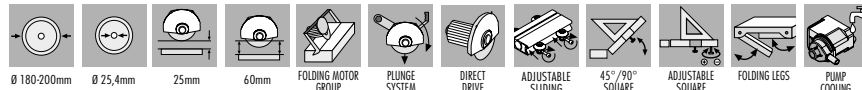

AVAILABLE BLADES

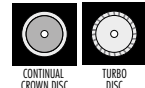

BOLT 90

4



4	225MS 90EU	8024648088659	1	Bolt 90 with blade Ø 250 mm (10") for porcelain	Single-phase	230 V 50 Hz	1,1	#3 1/2" 1"
4	225MS 90BR	8024648089717	1	Bolt 90 with blade Ø 250 mm (10") for porcelain	Single-phase	230 V 60 Hz	1,1	#3 1/2" 1"
4	225MS 90US	8024648089731	1	Bolt 90 with blade Ø 250 mm (10") for porcelain	Single-phase	110 V 60 Hz	1,1	#3 1/2" 1"
4	225MS 90GB	8024648089724	1	Bolt 90 with blade Ø 250 mm (10") for porcelain	Single-phase	110 V 50 Hz	1,1	#3 1/2" 1"

CUTTING SPECIFICATIONS AND MACHINE DIMENSIONS/WEIGHT

Model													
BOLT 90	250 mm	10"	55 mm	2 1/8"	30 mm	1 3/16"	90 cm	∞	63x63 cm	120x56x h50 cm	46 Kg	130x58xh 55 cm	56 Kg
										47 1/4" x 22" x h 19 5/8"	101.4 lbs	51 1/8" x 23" x h 21 5/8"	123.5 lbs

TECHNICAL CHARACTERISTICS

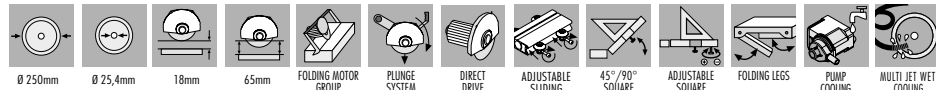

BOLT 120

5



5	225MS 120EU	8024648088673	1	Bolt 120 with blade Ø 250 mm (10") for porcelain	Single-phase	230 V 50 Hz	1,1	#3 1/2" 1"
5	225MS 120BR	8024648089755	1	Bolt 120 with blade Ø 250 mm (10") for porcelain	Single-phase	230 V 60 Hz	1,1	#3 1/2" 1"
5	225MS 120US	8024648089779	1	Bolt 120 with blade Ø 250 mm (10") for porcelain	Single-phase	110 V 60 Hz	1,1	#3 1/2" 1"
5	225MS 120GB	8024648089762	1	Bolt 120 with blade Ø 250 mm (10") for porcelain	Single-phase	110 V 50 Hz	1,1	#3 1/2" 1"

CUTTING SPECIFICATIONS AND MACHINE DIMENSIONS/WEIGHT

Model													
BOLT 120	250 mm	10"	55 mm	2 1/8"	30 mm	1 3/16"	120 cm	∞	85x85 cm	150x56x h50 cm	50 Kg	160x65xh 55 cm	66 Kg
										59" x 22" x h 19 5/8"	110.2 lbs	63" x 25 1/2" x h 21 5/8"	145.5 lbs

TECHNICAL CHARACTERISTICS

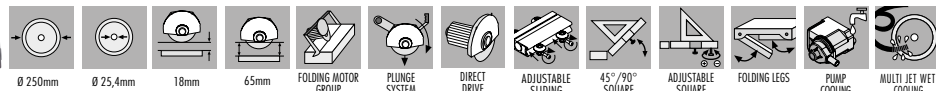

**BOLT 150**

7



7	225MS 150EU	8024648089809	1	Bolt 150 with blade Ø 250 mm (10") for porcelain	Single-phase	230 V 50 Hz	1,1	#20' 1" ¹¹
7	225MS 150BR	8024648089793	1	Bolt 150 with blade Ø 250 mm (10") for porcelain	Single-phase	230 V 60 Hz	1,1	#26' 1" ¹¹
7	225MS 150US	8024648089823	1	Bolt 150 with blade Ø 250 mm (10") for porcelain	Single-phase	110 V 60 Hz	1,1	#28' 1" ¹¹
7	225MS 150GB	8024648089816	1	Bolt 150 with blade Ø 250 mm (10") for porcelain	Single-phase	110 V 50 Hz	1,1	#28' 1" ¹¹

CUTTING SPECIFICATIONS AND MACHINE DIMENSIONS/WEIGHT

Model										
BOLT 150	250 mm 10"	55 mm 2 1/8"	30 mm 1 3/16"	150 cm 59"	∞	105x105 cm 41 3/8" x 41 3/8"	180x56x h50 cm 71" x 22" x h19 5/8"	56 Kg 123.5 lbs	195x65x h55 cm 76 3/4" x 25 1/2" x h 21 5/8"	72 Kg 158.7 lbs

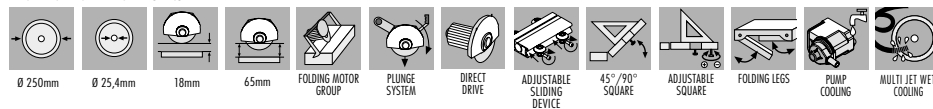
TECHNICAL CHARACTERISTICS**MISTRAL 90**

2



2	224MS 90EU	8024648088611	1	Mistral 90 with blade Ø 350 mm (14") for porcelain	Single-phase	230 V 50 Hz	2,2	#26' 1" ¹¹
2	224MS 90BR	8024648090492	1	Mistral 90 with blade Ø 350 mm (14") for porcelain	Single-phase	230 V 60 Hz	2,2	#26' 1" ¹¹
2	224MS 90US	8024648090508	1	Mistral 90 with blade Ø 350 mm (14") for porcelain	Single-phase	110 V 60 Hz	1,5	#26' 1" ¹¹

CUTTING SPECIFICATIONS AND MACHINE DIMENSIONS/WEIGHT

Model										
MISTRAL 90	350 mm 14"	100 mm 4"	60 mm 2 3/8"	90 cm 35 1/2"	∞	63x63 cm 25" x 25"	120x60x h60 cm 47 1/4" x 23 5/8" x h23 5/8"	60 Kg 132.3 lbs	130x58x h72 cm 51 1/8" x 22 3/4" x h 28 3/8"	70 Kg 154.3 lbs

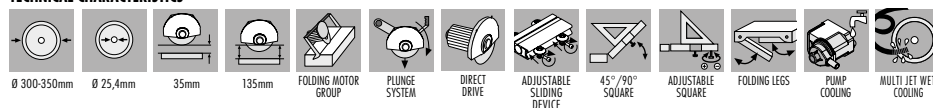
TECHNICAL CHARACTERISTICS**MISTRAL 120**

3



3	224MS 120EU	8024648088628	1	Mistral 120 with blade Ø 350 mm (14") for porcelain	Single-phase	230 V 50 Hz	2,2	#28' 1" ¹¹
3	224MS 120BR	8024648090522	1	Mistral 120 with blade Ø 350 mm (14") for porcelain	Single-phase	230 V 60 Hz	2,2	#28' 1" ¹¹
3	224MS 120US	8024648090539	1	Mistral 120 with blade Ø 350 mm (14") for porcelain	Single-phase	110 V 60 Hz	1,5	#28' 1" ¹¹

CUTTING SPECIFICATIONS AND MACHINE DIMENSIONS/WEIGHT

Model										
MISTRAL 120	350 mm 14"	100 mm 4"	60 mm 2 3/8"	120 cm 47 1/4"	∞	85x85 cm 33 1/2" x 33 1/2"	150x60x h60 cm 59" x 23 5/8" x h23 5/8"	63 Kg 138.9 lbs	165x65x h72 cm 65" x 25 1/2" x h 28 3/8"	83 Kg 183 lbs

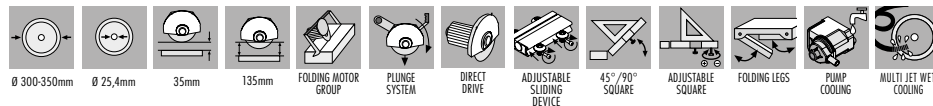
TECHNICAL CHARACTERISTICS**MISTRAL 150**

4



4	224MS 150EU	8024648088635	1	Mistral 150 with blade Ø 350 mm (14") for porcelain	Single-phase	230 V 50 Hz	2,2	#28' 1" ¹¹
4	224MS 150BR	8024648090553	1	Mistral 150 with blade Ø 350 mm (14") for porcelain	Single-phase	230 V 60 Hz	2,2	#28' 1" ¹¹
4	224MS 150US	8024648090560	1	Mistral 150 with blade Ø 350 mm (14") for porcelain	Single-phase	110 V 60 Hz	1,5	#28' 1" ¹¹

CUTTING SPECIFICATIONS AND MACHINE DIMENSIONS/WEIGHT

Model										
MISTRAL 150	350 mm 14"	100 mm 4"	60 mm 2 3/8"	150 cm 59"	∞	105x105 cm 41 3/8" x 41 3/8"	180x60x h60 cm 71" x 23 5/8" x h23 5/8"	73 Kg 160.9 lbs	195x65x h72 cm 77" x 25 1/2" x h 28 3/8"	90 Kg 198.4 lbs

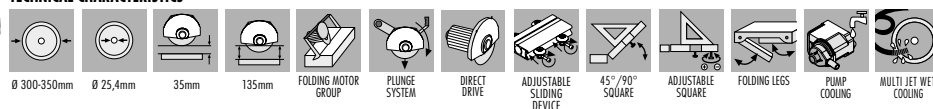
TECHNICAL CHARACTERISTICS



PIKUS 85 ADVANCED

1



1	424ADV	8024648054791	1	Pikus 85 ADV with blade Ø 250 mm (10") for porcelain	Single-phase	230V 50Hz	1,1	#Z\$*1"
1	424ADV 60	8024648055941	1	Pikus 85 ADV with blade Ø 250 mm (10") for porcelain	Single-phase	230V 60Hz	1,1	#Z\$*1"
1	424ADV US	8024648054807	1	Pikus 85 ADV with blade Ø 250 mm (10") for porcelain	Single-phase	110V 60Hz	1	#Z\$*1"
1	424ADV GB	8024648055934	1	Pikus 85 ADV with blade Ø 250 mm (10") for porcelain	Single-phase	115V 50Hz	1,1	#Z\$*1"

CUTTING SPECIFICATIONS AND MACHINE DIMENSIONS/WEIGHT

Model										
PIKUS 85 ADVANCED	250 mm 10"	80 mm 3 1/8"	55 mm 2 1/8"	85 cm 33 1/2"	∞	60x60 cm 23 5/8"x23 5/8"	125x70xh 79 cm 50"x27"x h 31"	60 Kg 132.3 lbs	150x73xh 95cm 59"x29"x h 37"	78 Kg 172 lbs

TECHNICAL CHARACTERISTICS

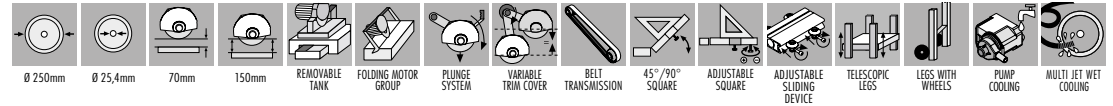

PIKUS 105 ADVANCED

2



2	423ADV	8024648055163	1	Pikus 105 ADV with blade Ø 250 mm (10") for porcelain	Single-phase	230V 50Hz	1,1	#Z%1"
2	423ADV 60	8024648055927	1	Pikus 105 ADV with blade Ø 250 mm (10") for porcelain	Single-phase	230V 60Hz	1,1	#Z\$*1"
2	423ADV US	8024648055910	1	Pikus 105 ADV with blade Ø 250 mm (10") for porcelain	Single-phase	110V 60Hz	1	#Z\$*1"
2	423ADV GB	8024648055903	1	Pikus 105 ADV with blade Ø 250 mm (10") for porcelain	Single-phase	115V 50Hz	1,1	#Z\$*1"

CUTTING SPECIFICATIONS AND MACHINE DIMENSIONS/WEIGHT

Model										
PIKUS 105 ADVANCED	250 mm 10"	80 mm 3 1/8"	55 mm 2 1/8"	105 cm 41 3/8"	∞	75x75 cm 29 1/2"x29 1/2"	145x70xh 79 cm 57"x27"x h 31"	64 Kg 141 lbs	150x73xh 95cm 59"x29"x h 37"	82 Kg 181 lbs

TECHNICAL CHARACTERISTICS

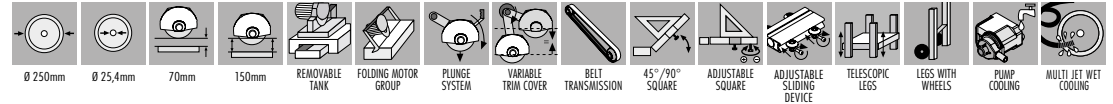

PIKUS 130 ADVANCED

3



3	425ADV	8024648055170	1	Pikus 130 ADV with blade Ø 250 mm (10") for porcelain	Single-phase	230V 50Hz	1,1	#Z\$*1"
3	425ADV 60	8024648055972	1	Pikus 130 ADV with blade Ø 250 mm (10") for porcelain	Single-phase	230V 60Hz	1,1	#Z\$*1"
3	425ADV US	8024648055965	1	Pikus 130 ADV with blade Ø 250 mm (10") for porcelain	Single-phase	110V 60Hz	1	#Z\$*1"
3	425ADV GB	8024648055958	1	Pikus 130 ADV with blade Ø 250 mm (10") for porcelain	Single-phase	115V 50Hz	1,1	#Z\$*1"

CUTTING SPECIFICATIONS AND MACHINE DIMENSIONS/WEIGHT

Model										
PIKUS 130 ADVANCED	250 mm 10"	80 mm 3 1/8"	55 mm 2 1/8"	130 cm 51 1/8"	∞	90 x 90 cm 35 3/8"x35 3/8"	170x70xh 79 cm 68"x27"x h 31"	78 Kg 172 lbs	200x80xh 110cm 78 3/4"x31 1/2"x h 43 3/8"	119 Kg 264.4 lbs

TECHNICAL CHARACTERISTICS

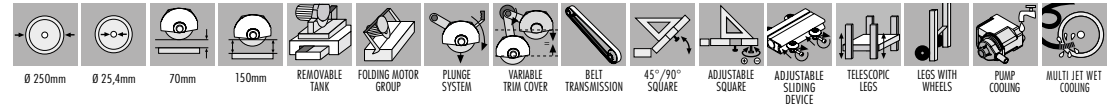

SMS 100

4



4	223MS100EUP	8050532006690	1	SMS 100 with blade Ø 350 mm (14") for porcelain	Single-phase	230 V 50 Hz	2,2	#Z&1"
4	223MS100V400P	8050532006461	1	SMS 100 with blade Ø 350 mm (14") for porcelain	Three-phase	400 V 50 Hz	2,2	#Z\$*1"
4	223MS100BRP	8050532006829	1	SMS 100 with blade Ø 350 mm (14") for porcelain	Single-phase	230 V 60 Hz	2,2	#Z\$*1"
4	223MS100USP	8050532006836	1	SMS 100 with blade Ø 350 mm (14") for porcelain	Single-phase	110 V 60 Hz	1,5	#Z\$*1"

CUTTING SPECIFICATIONS AND MACHINE DIMENSIONS/WEIGHT

Model										
SMS 100	350 mm 14"	100 mm 4"	60 mm 2 3/8"	100 cm 39 3/8"	∞	70x70 cm 27 1/2"x 27 1/2"	147x70xh85 cm 58"x27 1/2" xh 33 1/2"	80 Kg 176.4 lbs	150x73x h95 cm 59"x29"x h37"	98 Kg 216.1 lbs

TECHNICAL CHARACTERISTICS

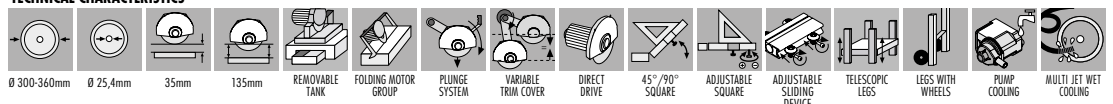



SMS 125



7	223MS125EUP	8050532006706	1	SMS 125 with blade Ø 350 mm (14") for porcelain ⓘ	Single-phase	230 V 50 Hz	2,2	#Z+1"1"
7	223MS125V400P	8050532006478	1	SMS 125 with blade Ø 350 mm (14") for porcelain ⓘ	Three-phase	400 V 50 Hz	2,2	#Z+8"1"
7	223MS125BRP	8050532006843	1	SMS 125 with blade Ø 350 mm (14") for porcelain ⓘ	Single-phase	230 V 60 Hz	2,2	#Z+8"1"
7	223MS125USP	8050532006850	1	SMS 125 with blade Ø 350 mm (14") for porcelain ⓘ	Single-phase	110 V 60 Hz	1,5	#Z+8"1"

CUTTING SPECIFICATIONS AND MACHINE DIMENSIONS/WEIGHT

Model										
SMS 125	350 mm 14"	100 mm 4"	60 mm 2 3/8"	125 cm 49 1/4"	∞	88x88 cm 34 5/8"x34 5/8"	175x70xh85 cm 69"x27 1/2"xh33 1/2"	84 Kg	200x80xh110 cm 783/4"x31 1/2"xh433/8"	125 Kg 275.6 lbs

TECHNICAL CHARACTERISTICS

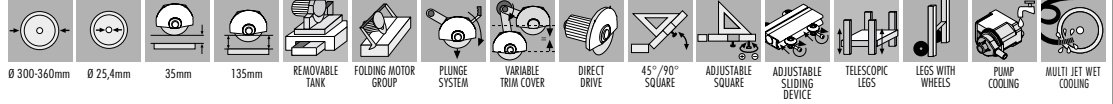

SMS 150



2	223MS150EUP	8050532002760	1	SMS 150 with blade Ø 350 mm (14") for porcelain ⓘ	Single-phase	230 V 50 Hz	2,2	#Z+1"1"
2	223MS150V400	8050532005471	1	SMS 150 with blade Ø 350 mm (14") for porcelain ⓘ	Three-phase	400 V 50 Hz	2,2	\$Z+8"1"
2	223MS150BRP	8050532002753	1	SMS 150 with blade Ø 350 mm (14") for porcelain ⓘ	Single-phase	230 V 60 Hz	2,2	\$Z+8"1"
2	223MS150USP	8050532002777	1	SMS 150 with blade Ø 350 mm (14") for porcelain ⓘ	Single-phase	110 V 60 Hz	1,5	\$Z+8"1"

CUTTING SPECIFICATIONS AND MACHINE DIMENSIONS/WEIGHT

Model										
SMS 150	350 mm 14"	100 mm 4"	60 mm 2 3/8"	150 cm 59"	∞	106x106 cm 41 5/8"x41 5/8"	200x70xh85 cm 78 3/4"x27 1/2"xh33 1/2"	89 Kg	200x80xh110 cm 78 3/4"x31 1/2"xh43 3/8"	130 Kg 286.6 lbs

TECHNICAL CHARACTERISTICS

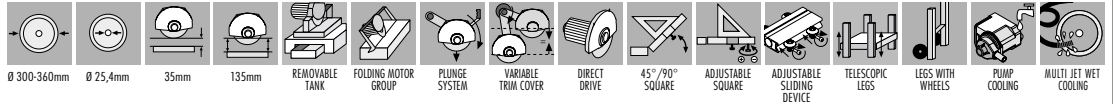

SMS 220



3	223MS200EU	8024648096289	1	SMS 220 with blade Ø 350 mm (14") for porcelain ⓘ	Single-phase	230 V 50 Hz	2,2	2.535,00
3	223MS200V400	8050532005518	1	SMS 220 with blade Ø 350 mm (14") for porcelain ⓘ	Three-phase	400 V 50 Hz	2,2	2.615,00
3	223MS200BR	8024648096265	1	SMS 220 with blade Ø 350 mm (14") for porcelain ⓘ	Single-phase	230 V 60 Hz	2,2	2.585,00
3	223MS200US	8024648096302	1	SMS 220 with blade Ø 350 mm (14") for porcelain ⓘ	Single-phase	110 V 60 Hz	1,5	2.595,00

CUTTING SPECIFICATIONS AND MACHINE DIMENSIONS/WEIGHT

Model										
SMS 220	350 mm 14"	90 mm 3 1/2"	50 mm 2"	220 cm 86 2/3"	∞	155x155 cm 61"x61"	270x85xh85 cm 106"x33 1/2"xh33 1/2"	120 Kg	275x85xh92 cm 108 1/4"x33 1/2"xh36 1/5"	208 Kg 458.6 lbs

TECHNICAL CHARACTERISTICS

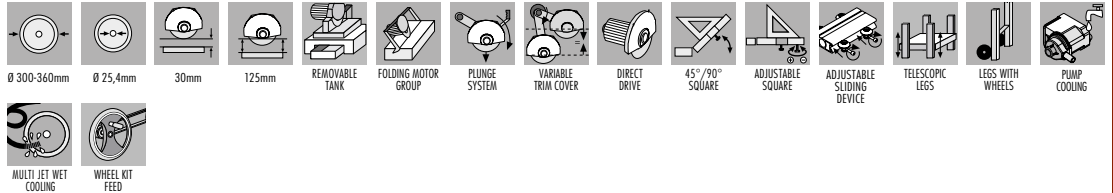

SMS 260



4	223MS260EU	8050532001756	1	SMS 260 with blade Ø 350 mm (14") for porcelain & side bench ⓘ	Single-phase	230 V 50 Hz	2,2	4.800,00
4	223MS260V400	8050532005532	1	SMS 260 with blade Ø 350 mm (14") for porcelain & side bench ⓘ	Three-phase	400 V 50 Hz	2,2	4.880,00
4	223MS260BR	8050532001589	1	SMS 260 with blade Ø 350 mm (14") for porcelain & side bench ⓘ	Single-phase	230 V 60 Hz	2,2	4.850,00
4	223MS260US	8050532001640	1	SMS 260 with blade Ø 350 mm (14") for porcelain & side bench ⓘ	Single-phase	110 V 60 Hz	1,5	4.860,00

CUTTING SPECIFICATIONS AND MACHINE DIMENSIONS/WEIGHT

Model									
SMS 260	350 mm 14"	90 mm 3 1/2"	260 cm 102 1/3"	181x181 cm 71"x71"	∞	310x75xh135 cm 122"x29 1/2"xh53"	199 Kg	315x95xh170 cm 124"x37 1/2"xh67"	279 Kg 615.1 lbs

TECHNICAL CHARACTERISTICS

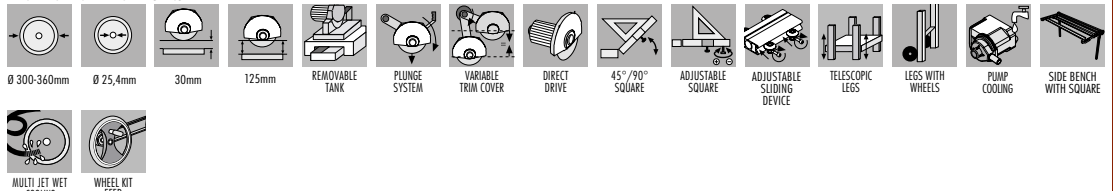

ZOE 85 ADVANCED



1	42085A P	8050532006744	1	Zoe 85 ADV with blade Ø 350 mm (14") for porcelain		Single-phase	230 V 50Hz	2,2	#Z & I"
1	42085A 400VP	8050532006898	1	Zoe 85 ADV with blade Ø 350 mm (14") for porcelain		Three-phase	400 V 50Hz	2,2	#Z+I"
1	42085A 60HZP	8050532006904	1	Zoe 85 ADV with blade Ø 350 mm (14") for porcelain		Single-phase	230 V 60Hz	2,2	#Z+I"
1	42085A USP	8050532006874	1	Zoe 85 ADV with blade Ø 350 mm (14") for porcelain		Single-phase	110 V 60Hz	1,65	#Z+I"
1	42085A GBP	8050532006867	1	Zoe 85 ADV with blade Ø 350 mm (14") for porcelain		Single-phase	115 V 50Hz	1,65	#Z+I"

CUTTING SPECIFICATIONS AND MACHINE DIMENSIONS/WEIGHT

Model											
ZOE 85 ADVANCED	Ø 350 mm 14"	110 mm 4 1/3"	80 mm 3 1/8"	85 cm 33 1/2"	∞	60x60 cm 23 5/8"x23 5/8"	125x70xh 95 cm 50"x27"x h 37"	80 Kg 176.4 lbs	150x73xh 110 cm 59"x29"x h 43"	98 Kg 216.1 lbs	

TECHNICAL CHARACTERISTICS

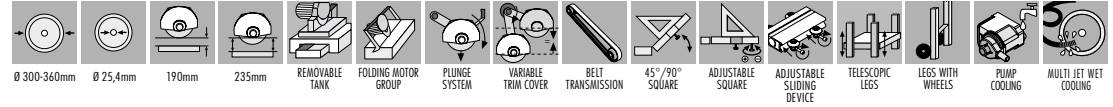

ZOE 105 ADVANCED



2	420105A P	8050532006508	1	Zoe 105 ADV with blade Ø 350 mm (14") for porcelain		Single-phase	230 V 50Hz	2,2	#Z+I"
2	420105A 400VP	8050532006539	1	Zoe 105 ADV with blade Ø 350 mm (14") for porcelain		Three-phase	400 V 50Hz	2,2	#Z+I"
2	420105A 60HZP	8050532006546	1	Zoe 105 ADV with blade Ø 350 mm (14") for porcelain		Single-phase	230 V 60Hz	2,2	#Z+I"
2	420105A USP	8050532006515	1	Zoe 105 ADV with blade Ø 350 mm (14") for porcelain		Single-phase	110 V 60Hz	1,65	#Z+I"
2	420105A GBP	8050532006492	1	Zoe 105 ADV with blade Ø 350 mm (14") for porcelain		Single-phase	115 V 50Hz	1,65	#Z+I"

CUTTING SPECIFICATIONS AND MACHINE DIMENSIONS/WEIGHT

Model											
ZOE 105 ADVANCED	Ø 350 mm 14"	110 mm 4 1/3"	80 mm 3 1/8"	105 cm 41 3/8"	∞	75 x 75 cm 29 1/2"x29 1/2"	145x70xh 95 cm 57"x27"x h 37"	84 Kg 185.2 lbs	150x73xh 110 cm 59"x29"x h 43"	102 Kg 224.9 lbs	

TECHNICAL CHARACTERISTICS

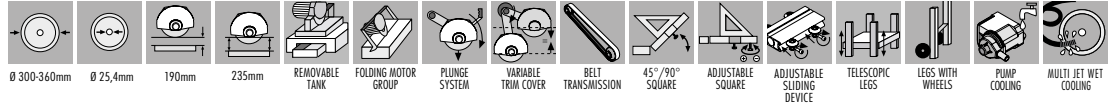

ZOE 130 ADVANCED



3	420130A P	8050532006560	1	Zoe 130 ADV with blade Ø 350 mm (14") for porcelain		Single-phase	230 V 50Hz	2,2	#Z+I"
3	420130A 400VP	8050532006584	1	Zoe 130 ADV with blade Ø 350 mm (14") for porcelain		Three-phase	400 V 50Hz	2,2	#Z+I"
3	420130A 60HZP	8050532006591	1	Zoe 130 ADV with blade Ø 350 mm (14") for porcelain		Single-phase	230 V 60Hz	2,2	#Z+I"
3	420130A USP	8024648056900	1	Zoe 130 ADV with blade Ø 350 mm (14") for porcelain		Single-phase	110 V 60Hz	1,65	#Z+I"
3	420130A GBP	8050532006553	1	Zoe 130 ADV with blade Ø 350 mm (14") for porcelain		Single-phase	115 V 50Hz	1,65	#Z+I"

CUTTING SPECIFICATIONS AND MACHINE DIMENSIONS/WEIGHT

Model											
ZOE 130 ADVANCED	Ø 350 mm 14"	110 mm 4 1/3"	80 mm 3 1/8"	130 cm 51 1/8"	∞	90 x 90 cm 35 3/8"x35 3/8"	170x70xh 95 cm 68"x27"x h 37"	98 Kg 216 lbs	200x80xh 110 cm 78 3/4"x30"x h 43"	139 Kg 306.4 lbs	

TECHNICAL CHARACTERISTICS

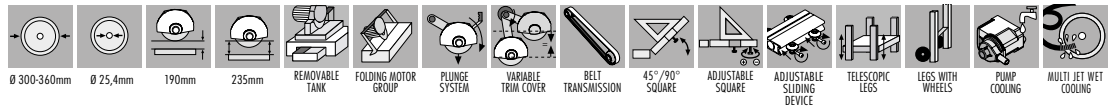

ZOE 150 ADVANCED



4	420150A AP	8050532002692	1	Zoe 150 ADV with blade 350 mm (14") for porcelain		Single-phase	230 V 50Hz	2,2	#Z+I"
4	420150A 400P	8050532002739	1	Zoe 150 ADV with blade 350 mm (14") for porcelain		Three-phase	400 V 50Hz	2,2	#Z+I"
4	420150A 60HP	8050532002746	1	Zoe 150 ADV with blade 350 mm (14") for porcelain		Single-phase	230 V 60Hz	2,2	#Z+I"
4	420150A USP	8050532002715	1	Zoe 150 ADV with blade 350 mm (14") for porcelain		Single-phase	110 V 60Hz	1,65	#Z+I"
4	420150A GBP	8050532002760	1	Zoe 150 ADV with blade 350 mm (14") for porcelain		Single-phase	110 V 50Hz	1,65	#Z+I"

CUTTING SPECIFICATIONS AND MACHINE DIMENSIONS/WEIGHT

Model											
ZOE 150 ADVANCED	Ø 350 mm 14"	110 mm 4 1/3"	80 mm 3 1/8"	155 cm 61"	∞	109 x 109 cm 42 7/8"x42 7/8"	200x70xh 95 cm 78 3/4"x27"x h 37"	106 Kg 233.7 lbs	200x80xh 110 cm 78 3/4"x31 1/2"x h 37 1/2"	147 Kg 324 lbs	

TECHNICAL CHARACTERISTICS

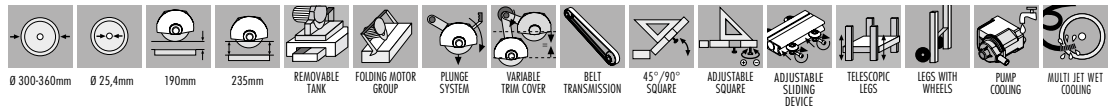



ACCESSORIES FOR EXPLOIT, BOLT, MISTRAL, PIKUS, PIKUS ADV, SMS, ZOE ADV

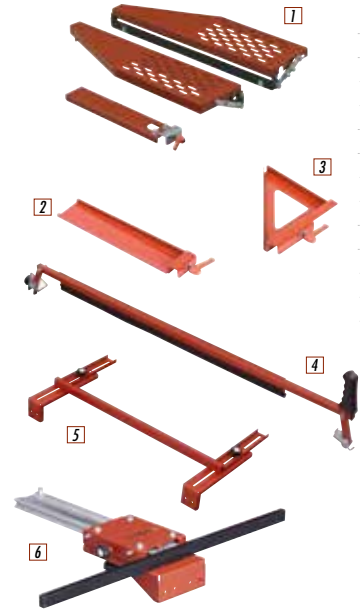

	Ref.	Part No.	Description	EXPLOIT			BOLT			MISTRAL			PIKUS			PIKUS ADV			SMS			ZOE				
				70	90	120	90	120	150	90	120	150	75	85	105	130	100	125	150	220	260	85	105	130		150
1	7	423KITDL	8024648010476	1	Extensions & left square 90°																					113,00
2	2	1925Q03A	8024648014986	1	Sliding square 90°																					19,50
3	3	1925Q07A	8024648053893	1	Left sliding square 45°/90°																					16,20
4	4	424BL75	8024648006622	1	Tile holding device																					59,50
4	4	423BL105ADV	8024648056757	1	Tile holding device																					76,40
4	4	423BL130ADV	8024648066459	1	Tile holding device																					109,00
4	4	423BL150ADV	8024648071187	1	Tile holding device																					118,00
5	5	191CL04A	8024648056122	1	Countersquare																					82,00
6	6	191CL04A1	8024648080998	1	Telescopic Countersquare 90°/45°																					198,00
7	7	191CL04A2	8024648088123	1	Countersquare																					90,00
8	8	374RUS40I	8024648090256	1	Self-standing 5 rollers bench (70x50cm)																					250,00
9	9	191CL05A	8024648058003	1	Countersquare for side tables with rollers																					86,00
10	10	315CR02K	8024648089908	1	4 Wheels + handles kit																					82,00

LASER FOR PIKUS ADV, SMS, ZOE ADV



	Ref.	Part No.	Description	EXPLOIT			BOLT			MISTRAL			PIKUS			PIKUS ADV			SMS			ZOE				
				70	90	120	90	120	150	90	120	150	75	85	105	130	100	125	150	220	260	85	105	130		150
11	11	411SE01A	8024648065254	1	Laser for wet saws without stirrup																					62,00
		411SE A2	8024648070913	1	Laser with stirrup for Pikus Adv																					79,00
		411SE A4	8024648070937	1	Laser with stirrup for SMS 100/125/150																					74,00
		411SE A9	8024648005663	1	Laser with stirrup for SMS 220/260																					74,00
		411SE A1	8024648070906	1	Laser with stirrup for Zoe Adv																					83,00

MANUAL FEED KIT WITH WHEEL FOR BOLT, MISTRAL, PIKUS ADV, SMS, ZOE ADV



	Ref.	Part No.	Description	EXPLOIT			BOLT			MISTRAL			PIKUS			PIKUS ADV			SMS			ZOE				
				70	90	120	90	120	150	90	120	150	75	85	105	130	100	125	150	220	260	85	105	130		150
12	12	419AVPK 085	8024648091543	1	Manual feed kit with wheel																					198,00
12	12	419AVPK 105	8024648091550	1	Manual feed kit with wheel																					200,00
12	12	419AVPK 130	8024648092755	1	Manual feed kit with wheel																					204,00
13	13	419AVBO=120	8024648090331	1	Manual feed kit with wheel																					177,00
13	13	419AVBO=150	8024648090348	1	Manual feed kit with wheel																					182,00
14	14	419AVMS=120	8024648090355	1	Manual feed kit with wheel																					173,50
14	14	419AVMS=150	8024648090362	1	Manual feed kit with wheel																					175,80
14	14	419AVMS=155	8024648022714	1	Manual feed kit with wheel																					178,00
15	15	419AVZO 085	8024648093233	1	Manual feed kit with wheel																					215,00
15	15	419AVZO 105	8024648093240	1	Manual feed kit with wheel																					224,00
15	15	419AVZO 130	8024648093257	1	Manual feed kit with wheel																					229,00
15	15	419AVZO 150	8024648093264	1	Manual feed kit with wheel																					231,00

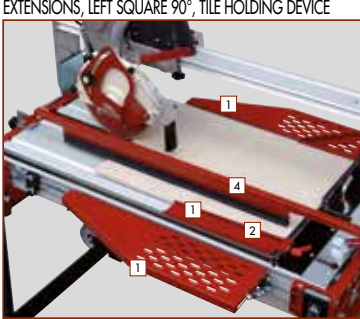

COUNTERSQUARE FOR SIDE TABLES WITH ROLLERS

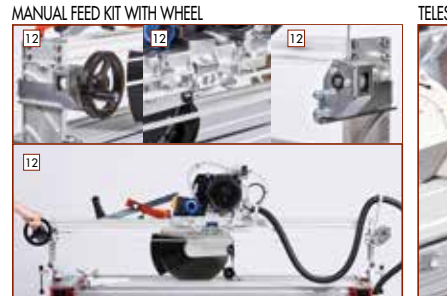

MANUAL FEED KIT WITH WHEEL



TELESCOPIC COUNTERSQUARE



LASER



SIDE BENCH WITH ADJUSTABLE SQUARE FOR PIKUS ADV, ZOE ADV E SMS



1	374BSQ 130	8024648099068	1	Side bench with adjustable square
1	374BSQ 150	8024648099075	1	Side bench with adjustable square
1	374BSQ 220	8024648099082	1	Side bench with adjustable square
2	374BSQ 260	8050532001718	1	Side bench with adjustable square

EXPLOIT	BOLT	MISTRAL	PIKUS	PIKUS ADV	SMS	ZOE	
70 90 120 90	120 150 90 120 150	90 120 150	75	85 105 130	100 125 150 220 260	85 105 130 150	
-	-	-	-	•	•	-	1.277,00
-	-	-	-	-	•	-	1.290,00
-	-	-	-	-	-	•	1.500,00
-	-	-	-	-	-	•	1.560,00



WATER CONTAINMENT BARS WITH NYLON BRUSHES FOR PIKUS ADV, ZOE ADV E SMS



3	263PE04A085	8024648019585	1	Water containment bars (pair)
3	263PE04A105	8024648019592	1	Water containment bars (pair)
3	263PE04A130	8024648022233	1	Water containment bars (pair)
3	263PE04A150	8024648022851	1	Water containment bars (pair)
3	263PE04A200	8024648026507	1	Water containment bars (pair)
3	263PE04A260	8050532001824	1	Water containment bars (pair)

EXPLOIT	BOLT	MISTRAL	PIKUS	PIKUS ADV	SMS	ZOE	
70 90 120 90	120 150 90 120 150	90 120 150	75	85 105 130	100 125 150 220 260	85 105 130 150	
-	-	-	-	•	-	-	100,00
-	-	-	-	•	-	-	105,00
-	-	-	-	-	•	-	114,00
-	-	-	-	-	•	-	118,00
-	-	-	-	-	•	-	143,00
-	-	-	-	-	•	-	154,00

FLANGES Ø 200 mm / 8"



4	278CP05D1	8024648079060	1	Flanges (pair) Ø 200 mm (8")
4	278CP05D2	8024648079077	1	Flanges (pair) Ø 200 mm (8")

EXPLOIT	BOLT	MISTRAL	PIKUS	PIKUS ADV	SMS	ZOE	
70 90 120 90	120 150 90 120 150	90 120 150	75	85 105 130	100 125 150 220 260	85 105 130 150	
-	-	-	-	-	•	•	60,00
-	-	-	-	-	•	•	60,00

DIAMOND DISCS FOR EXPLOIT



6	179SET200SP	8024648076137	1	Ø 200 mm (8") for porcelain tiles
5	179CC200E	8024648004086	1	Ø 200 mm (8") continuous rim (ceramic)
5	179CC180	8024648004093	1	Ø 180 mm (7") continuous rim (ceramic)

EXPLOIT	BOLT	MISTRAL	PIKUS	PIKUS ADV	SMS	ZOE	
70 90 120 90	120 150 90 120 150	90 120 150	75	85 105 130	100 125 150 220 260	85 105 130 150	
•	•	-	-	-	-	-	118,00
•	•	-	-	-	-	-	64,00
•	•	-	-	-	-	-	46,40

DIAMOND DISCS FOR BOLT, PIKUS, PIKUS ADV



8	179CCT250	8024648004000	1	Ø 250 mm (10") turbo (ceramic)
8	179CCT250E	8050532002319	1	Ø 250 mm (10") turbo (building materials)
7	179SET250SP	8024648080912	1	Ø 250 mm (10") segmented (porcelain)
7	179SET250BE	8024648055002	1	Ø 250 mm (10") segmented (porcelain)

EXPLOIT	BOLT	MISTRAL	PIKUS	PIKUS ADV	SMS	ZOE	
70 90 120 90	120 150 90 120 150	90 120 150	75	85 105 130	100 125 150 220 260	85 105 130 150	
-	•	•	-	•	•	-	186,00
-	•	•	-	•	•	-	105,00
-	•	•	-	•	•	-	160,00
-	•	•	-	•	•	-	97,00

DIAMOND DISCS FOR MISTRAL, SMS, ZOE ADV



9	179CCT300	8024648003997	1	Ø 300 mm (12") turbo (ceramic)
9	179CCT300E	8050532002326	1	Ø 300 mm (12") turbo (building materials)
10	179CC300	8024648004055	1	Ø 300 mm (12") continuous rim (ceramic)
11	179SET300	8024648004130	1	Ø 300 mm (12") segmented (building materials)
11	179SET300G	8024648004147	1	Ø 300 mm (12") segmented (granite)
12	179SET300B	8024648004154	1	Ø 300 mm (12") segmented (porcelain)
12	179SET300BS	8024648076076	1	Ø 300 mm (12") special segmented for porcelain
9	179CCT350	8024648003980	1	Ø 350 mm (14") turbo (ceramic)
9	179CCT350E	8050532002333	1	Ø 350 mm (14") turbo (building materials)
10	179CC350	8024648004048	1	Ø 350 mm (14") continuous rim (ceramic)
11	179SET360E	8024648054166	1	Ø 360 mm (14") segmented (building materials)
11	179SET350G	8024648005946	1	Ø 350 mm (14") segmented (granite)
12	179SET350B	8024648011022	1	Ø 350 mm (14") segmented (porcelain)

EXPLOIT	BOLT	MISTRAL	PIKUS	PIKUS ADV	SMS	ZOE	
70 90 120 90	120 150 90 120 150	90 120 150	75	85 105 130	100 125 150 220 260	85 105 130 150	
-	-	•	•	-	•	•	253,00
-	-	•	•	-	•	•	165,00
-	-	•	•	-	•	•	180,00
-	-	•	•	-	•	•	204,00
-	-	•	•	-	•	•	281,00
-	-	•	•	-	•	•	234,00
-	-	•	•	-	•	•	170,00
-	-	•	•	-	•	•	316,00
-	-	•	•	-	•	•	205,00
-	-	•	•	-	•	•	206,50
-	-	•	•	-	•	•	140,00
-	-	•	•	-	•	•	335,00
-	-	•	•	-	•	•	248,00



SA 80

7



7	218A	8024648019202	1	SA80 with Ø 360 mm (14") segmented diamond blade	Single-phase	230 V 50 Hz	2,2	1.640,00
7	218A60HZ	8024648019240	1	SA80 with Ø 360 mm (14") segmented diamond blade	Single-phase	230 V 60 Hz	2,2	1.700,00
7	218AUSA	8024648019226	1	SA80 with Ø 360 mm (14") segmented diamond blade	Single-phase	110 V 60 Hz	2,2	1.710,00
7	218AGB	8024648019219	1	SA80 with Ø 360 mm (14") segmented diamond blade	Single-phase	115 V 50 Hz	2,2	1.720,00

CUTTING SPECIFICATIONS AND MACHINE DIMENSIONS/WEIGHT

Model												
SA 80	300 mm	12"	95 mm	3 3/4"	40 mm	1 5/8"	80 cm	60 cm	50x50 cm	110x75xh 80 cm	77 Kg	120x80xh 100 cm
	360 mm	14"	120 mm	4 3/4"	65 mm	2 9/16"	31 1/2"	23 5/8"	20" x20"	169.8 lbs	47 1/4"x31 1/2" xh 39 3/8"	96 Kg

TECHNICAL CHARACTERISTICS

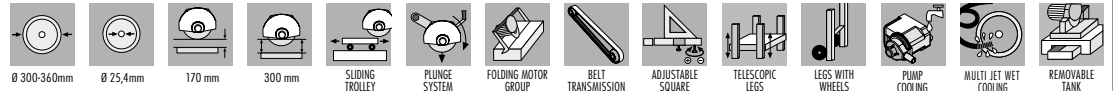

SA 09

2



2	203SA09	8024648064561	1	SA09 with Ø 360 mm (14") segmented diamond blade; without handles	Single-phase	230V 50Hz	2,2	1.345,00
2	203SA09 60HZ	8024648066510	1	SA09 with Ø 360 mm (14") segmented diamond blade; without handles	Single-phase	230V 60Hz	2,2	1.385,00
2	203SA09 US	8024648066503	1	SA09 with Ø 360 mm (14") segmented diamond blade; without handles	Single-phase	110V 60Hz	1,5	1.395,00

CUTTING SPECIFICATIONS AND MACHINE DIMENSIONS/WEIGHT

Model												
SA 09	SINGLE PASS	360 mm	105 mm	210 mm	50 mm	80 cm	60 cm	50x50cm	120x70xh 75 cm	80 Kg	120x80xh 100 cm	99 Kg
		14"	4 1/8"	8 1/4"	2"	31 1/2"	23 5/8"	20"x20"	47"x27 1/2"xh 29 1/2"	176.4 lbs	47"x31 1/2"xh 39 3/8"	218.3 lbs
	DOUBLE PASS	406 mm	125 mm	250 mm	70 mm	80 cm	60 cm	50x50cm	120x70xh 75 cm	80 Kg	120x80xh 100 cm	99 Kg
		16"	5"	10"	2 3/4"	31 1/2"	23 5/8"	20"x20"	47"x27 1/2"xh 29 1/2"	176.4 lbs	47"x31 1/2"xh 39 3/8"	218.3 lbs

TECHNICAL CHARACTERISTICS

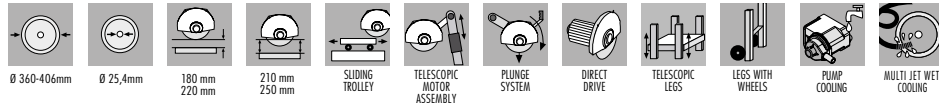

* handles not included.

SHERPA

3



3	218AS 230SD	8024648017659	1	SHERPA without blade	Single-phase	230V 50Hz	2,4	2.790,00
3	218AS 400SDN	8024648082466	1	SHERPA without blade	Three-phase	400V 50Hz	3,3	3.010,00

CUTTING SPECIFICATIONS AND MACHINE DIMENSIONS/WEIGHT

Model												
SHERPA		630 mm	25 cm	13 cm	25 cm	9 7/8"	45 cm	17 11/16"	49x49 cm	137 Kg	170x90xh 140 cm	179 Kg
		25"	10"	5 1/8"	14 cm	5 1/2"	70 cm	27 1/2"	19 9/32"x19 9/32"	302 lbs	67"x35 1/2"xh 55"	394.6 lbs
		500 mm	18 cm	11 cm	18 cm	7"	70 cm	27 1/2"	57"x30"xh 43"	302 lbs	67"x35 1/2"xh 55"	394.6 lbs

TECHNICAL CHARACTERISTICS

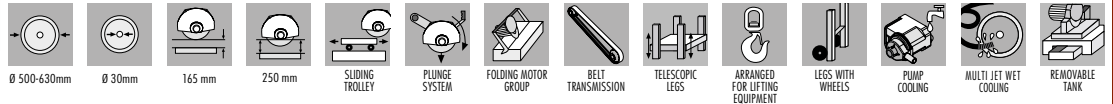

GS86



1	125INOX F	8024648003584	1	GS 86 with Ø 115 mm (4 1/2") turbo blade	Single-phase	230 V 50 Hz	0,66	1.000,00
1	125INOX 60	8024648017055	1	GS 86 with Ø 115 mm (4 1/2") turbo blade	Single-phase	230 V 60 Hz	0,66	1.000,00
1	125INOX US	8024648009265	1	GS 86 with Ø 115 mm (4 1/2") turbo blade	Single-phase	110 V 60 Hz	0,66	1.010,00
1	125INOX GB	8024648009258	1	GS 86 with Ø 115 mm (4 1/2") turbo blade	Single-phase	115 V 50 Hz	0,66	1.010,00

CUTTING SPECIFICATIONS AND MACHINE DIMENSIONS/WEIGHT

Model													
GS 86	100 mm 115 mm	4" 4 1/2"	18 mm 25 mm	25/32" 1"	10 mm 10 mm	4" 4"	∞	∞	∞	45x45xh 30 cm 17 3/4"x17 3/4"xh 11 7/8"	25 Kg 55.1 lbs	50x50xh 35 cm 19 3/4"x19 3/4"xh 13 3/4"	26 Kg 57.3 lbs

TECHNICAL CHARACTERISTICS

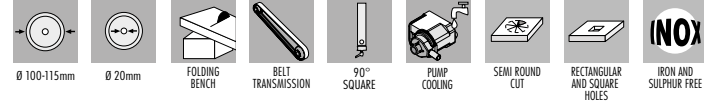

ECO 92



2	370 DF	8024648003607	1	ECO 92 with blade Ø 200 mm (8") continuous rim	Single-phase	230 V 50/60 Hz	0,66	470,00
2	370 USA	8024648010384	1	ECO 92 with blade Ø 200 mm (8") continuous rim	Single-phase	110 V 60 Hz	0,66	490,00
2	370 GB	8024648009289	1	ECO 92 with blade Ø 200 mm (8") continuous rim	Single-phase	115 V 50 Hz	0,66	490,00

CUTTING SPECIFICATIONS AND MACHINE DIMENSIONS/WEIGHT

Model										
ECO 92	200 mm 7 7/8"	36 mm 1 3/8"	40 mm 1 5/8"	∞	∞	∞	47x45xh 27 cm 18 1/2"x17 3/4"xh 10 5/8"	16 Kg 35.3 lbs	50x50xh 32 cm 19 3/4"x19 3/4"xh 12 5/8"	17 Kg 37.5 lbs

TECHNICAL CHARACTERISTICS

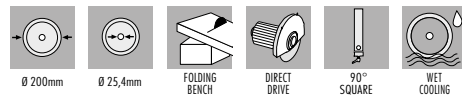

SUPERECO 98



3	378 98	8024648003621	1	SUPERECO 98 with Ø 150 mm (6") continuous rim blade	Single-phase	230 V 50/60 Hz	0,37	330,00
3	378 USA	8024648008824	1	SUPERECO 98 with Ø 150 mm (6") continuous rim blade	Single-phase	110 V 60 Hz	0,24	310,00
3	378 GB	8024648008800	1	SUPERECO 98 with Ø 150 mm (6") continuous rim blade	Single-phase	115 V 50 Hz	0,24	310,00

CUTTING SPECIFICATIONS AND MACHINE DIMENSIONS/WEIGHT

Model										
SUPERECO 98	150 mm 6"	20 mm 13/16"	30 mm 1 3/16"	∞	∞	∞	45x42xh 22 cm 17 3/4"x16 1/2"xh 8 5/8"	11 Kg 24 lbs	50x45xh 30 cm 19 5/8"x17 3/4"xh 11 7/8"	12 Kg 26 lbs

TECHNICAL CHARACTERISTICS

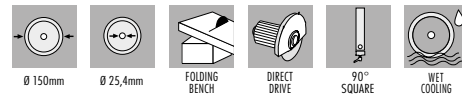

**ACCESSORIES AND DIAMOND DISCS FOR SA80, SA09, SHERPA E TS94/60**

				SA80	SA09	SHERPA	
1	218DJ	8024648009777	1	-	•	-	72,00
2	154SE17CP	8024648066480	1	•	•	•	53,50
3	192SQ24A	8024648005656	1	•	•	•	48,00
4	191CL05A	80246480058003	1	•	-	-	86,00
5	179CCT300	8024648003997	1	•	-	-	253,00
6	179CCT300E	8050532002326	1	•	-	-	165,00
6	179CC300	8024648004055	1	•	-	-	180,00
7	179SET300G	8024648004147	1	•	-	-	281,00
8	179SET300B	8024648004154	1	•	-	-	234,00
9	179SET300BS	80246480076076	1	•	-	-	170,00
9	179CCT350	8024648003980	1	•	•	-	316,00
6	179CCT350E	8050532002333	1	•	•	-	205,00
6	179CC350	8024648004048	1	•	•	-	206,50
7	179SET360E	80246480054166	1	•	•	-	140,00
8	179SET350G	8024648005946	1	•	•	-	335,00
8	179SET350B	8024648011022	1	•	•	-	248,00
8	179SET400TU	8024648065667	1	-	•	-	230,00
8	179SET500	8024648017925	1	-	-	•	290,00
8	179SET600	8024648059536	1	-	-	•	320,00
8	179SET600CF	8024648060761	1	-	-	•	445,00

**LASER FOR SA80, SA09, SHERPA**

				SA80	SA09	SHERPA	
9	411SE01A	8024648065254	1	-	-	-	62,00
	411SE A4	8024648070937	1	•	-	-	74,00
	411SE A3	8024648070920	1	-	-	•	78,00

DIAMOND DISCS FOR GS86, ECO92, SUPRECO 98

				GS86	ECO92	SUPRECO98	
10	179CCT115	8024648004024	1	•	-	-	77,40
11	179CC115	8024648004192	1	•	-	-	69,70
11	179CC200E	8024648004086	1	-	•	-	64,00
11	179CC150	8024648004109	1	-	-	•	36,00

**CM 180 AUTOMATIC
(AUTOMATIC FEED)**



1	379ADV 230	8024648065834	1 CM 180 Auto with bench-square; without disc & tile-holder		Single-phase	230 V 50 Hz	2,2	11.500,00
	379ADV 230/6	8024648073105	1 CM 180 Auto with bench-square; without disc & tile-holder		Single-phase	230 V 60 Hz	2,2	11.650,00
	379ADV 400DE	8024648079985	1 CM 180 Auto with bench-square; without disc & tile-holder		Three-phase	400 V 50 Hz	2,2	11.680,00

CUTTING SPECIFICATIONS AND MACHINE DIMENSIONS/WEIGHT

Model										
CM 180 AUTOMATICA	360 mm 14"	120 mm 4 3/4"	65 mm 2 9/16"	180 cm 70 7/8"	100 cm 39 3/8"	125x125 cm 49 1/4"x49 1/4"	280x200xh 150 cm 110"x78 3/4"xh 59"	450 Kg 992 lbs	300x130xh 177 cm 118"x51"xh 69 3/4"	542 Kg 1194 lbs

TECHNICAL CHARACTERISTICS

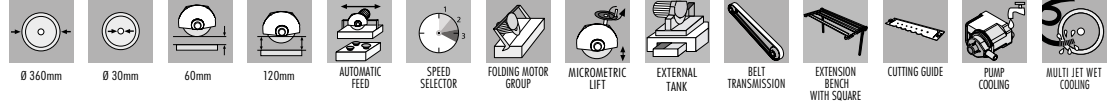

DISC COVER KIT FOR CM 180 AUTOMATIC



2	379AKITDMI	8024648072542	1 Disc-cover-kit for multi-blades cut for CM 180 Automatic					285,00
	379AKITMT	8024648073112	1 Universal flanges-kit for multi-blades cut					265,00
	379AKIT2T	8024648073143	1 Multi-blades flanges-kit for cut & bevel (max 2 discs)					136,30
	379AKITSCAN	8024648073129	1 Multi-blades flanges-kit multi-blades for grooves					182,00

**ACCESSORIES FOR CM 180 AUTOMATIC AND
CM 150 AUTOMATIC**



				CM180 AUTO	CM150 AUTO	
4	379BLOADVN	8024648082374	1 Extension bench with square for CM 180 Auto	•	–	415,00
5	379BLOPIA	8024648011862	1 Tile holding device ADV for CM 150 Auto	–	•	235,00
6	374RUSD40CM180	8024648095473	1 Self-standing 5 rollers bench (70x50cm - 27 1/2" x 19 5/8") for CM180 Auto	•	–	265,00
6	374RUSD40ICM	8024648078674	1 Self-standing 5 rollers bench (70x50cm - 27 1/2" x 19 5/8") for CM 150 Auto	–	•	275,00
7	191CLO5A	8024648058003	1 Extension side square for rolling side tables	•	–	86,00
8	192SQ21A	8024648011893	1 Sliding V square for diagonal cut for extension bench	•	–	27,90
9	411SE A6	8024648070951	1 Laser with stirrup for CM 180 Auto	•	–	88,00
10	379AKITRUOTE	8024648090270	1 Kit of 4 supports with 4 wheels each for CM180 Auto	•	–	390,00



**Ø 200 mm (8") FLANGES FOR CM 180 AUTOMATIC
AND CM 150 AUTOMATIC**



				CM180 AUTO	CM150 AUTO	
11	278CP05D1	8024648079060	1 Flanges (pair) Ø 200 mm (8") for CM 180 Auto	•	–	60,00
11	278CP05D	8024648059390	1 Flanges (pair) Ø 200 mm (8") for CM 150 Auto	–	•	66,00

**DIAMOND DISCS FOR CM 180 AUTOMATIC
AND CM 150 AUTOMATIC**



				CM180 AUTO	CM150 AUTO	
12	179CCT300	8024648003997	1 Ø 300 mm (12") turbo diamond blade (ceramic)	•	•	253,00
12	179CCT300E	8050532002326	1 Ø 300 mm (12") turbo (building materials)	–	•	165,00
13	179CC300	8024648004055	1 Ø 300 mm (12") continuous rim diamond blade (ceramic)	•	•	180,00
14	179SET300	8024648004130	1 Ø 300 mm (12") segmented diamond blade (building materials)	–	•	204,00
14	179SET300G	8024648004147	1 Ø 300 mm (12") segmented diamond blade (granite)	•	•	281,00
15	179SET300B	8024648004154	1 Ø 300 mm (12") segmented diamond blade (porcelain)	•	•	234,00
15	179SET300BS	8024648076076	1 Ø 300 mm (12") segmented diamond disc for porcelain	•	•	170,00
12	179CCT350	8024648003980	1 Ø 350 mm (14") continuous rim diamond blade (ceramic)	•	–	316,00
12	179CCT350E	8050532002333	1 Ø 350 mm (14") turbo (building materials)	•	–	205,00
13	179CC350	8024648004048	1 Ø 350 mm (14") continuous rim diamond blade (ceramic)	•	–	206,50
14	179SET360E	8024648054166	1 Ø 360 mm (14") segmented diamond blade (building materials)	•	–	140,00
14	179SET350G	8024648005946	1 Ø 350 mm (14") segmented diamond blade (granite)	•	–	335,00
15	179SET350B	8024648011022	1 Ø 350 mm (14") segmented diamond blade (porcelain)	•	–	248,00
13	179C250B	8024648004161	1 Ø 250 mm (10") continuous rim V45° diamond blade for bevel	•	•	198,00
16	179SCAN4D300	8024648071415	1 Ø 300 mm (12") diamond disc for grooves / engraving - thickness 4 mm	•	–	230,00
17	288YA46	8024648079619	1 Sharpening stone for diamond disc 45x230x25 mm	•	•	11,00

**JOLLY ADV (AUTOMATIC FEED)**

7



7	354J1200 CSQ	8024648093370	1	Jolly Adv with blade Ø 200 mm (8") continuous rim	Single-phase	230 V 50 Hz	1,5	9.000,00
---	---------------------	---------------	---	---	--------------	-------------	-----	-----------------

CUTTING SPECIFICATIONS AND MACHINE DIMENSIONS/WEIGHT

Model								
JOLLY ADV	200 mm	—	15 mm	120 cm		287 Kg	165x125xh 145 cm 65"x49 1/4"xh 57"	185x135xh 105 cm 73"x53"xh 41 1/4"
	8"	—	5/8"	47 1/4"				

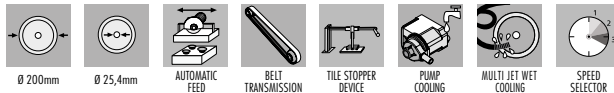
TECHNICAL CHARACTERISTICS**JOLLYNA**

2



2	431J2015EU	8024648091086	1	Jollyna with blade Ø 200 mm (8") continuous rim	Single-phase	230 V 50 Hz	1,1	1.725,00
2	431J2015BR	8024648094865	1	Jollyna with blade Ø 200 mm (8") continuous rim	Single-phase	230 V 60 Hz	1,1	1.760,00
2	431J2015US	8024648094889	1	Jollyna with blade Ø 200 mm (8") continuous rim	Single-phase	110 V 60 Hz	1,1	1.780,00
2	431J2015GB	8024648094872	1	Jollyna with blade Ø 200 mm (8") continuous rim	Single-phase	110 V 50 Hz	1,1	1.780,00

CUTTING SPECIFICATIONS AND MACHINE DIMENSIONS/WEIGHT

Model								
JOLLYNA	200 mm	—	20 mm	120 cm		59 Kg	55x85x h 80 cm 22"x33 1/2"x h 31 1/2"	90x72x h 90 cm 35 1/2"x28 3/8"x h 35 1/2"
	8"	—	13/16"	47 1/4"				

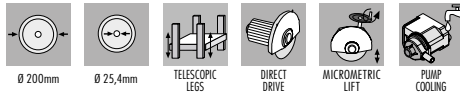
TECHNICAL CHARACTERISTICS**ACCESSORIES FOR JOLLY ADV, JOLLYNA**

				JOLLY ADV	JOLLYNA	JOLLY 1000		
3	431EP01A	8024648092878	1	Extension side table for tiles (120x80 cm - 47 1/4"x31 1/2") for Jollyna	-	•	-	249,00
	431PR02A	8024648092946	1	Left and right extension for Jollyna - pair	-	•	-	262,00
4	192SQ21A	8024648011893	1	Sliding V square for diagonal cut for Jolly 1000	-	-	•	27,90
5	179CC200	8024648004079	1	Ø 200 mm (8") continuous rim diamond blade (ceramic)	•	•	•	120,00

LEM 150 (VERTICAL CUT)



1	426 150	8024648069580	1	LEM 150 with Ø 200 mm (8") diamond disc for porcelain	Single-phase	230 V 50 Hz	0,9	2.890,00
	426 150 US	8024648079664	1	LEM 150 with Ø 200 mm (8") diamond disc for porcelain	Single-phase	110 V 60 Hz	0,9	2.925,00

CUTTING SPECIFICATIONS AND MACHINE DIMENSIONS/WEIGHT

Model										
LEM 150	200 mm 8"	40 mm 1 9/32"	30 mm 1 3/16"	150 cm 59"	∞	105x105 cm 41 3/8"x41 3/8"	240 x 65 x h65 cm 94 1/2"x25 1/2"xh25 1/2"	86 Kg 190 lbs	250x90x h85 cm 98 7/16"x41 3/8"xh43 3/8"	131 Kg 289 lbs

TECHNICAL CHARACTERISTICS

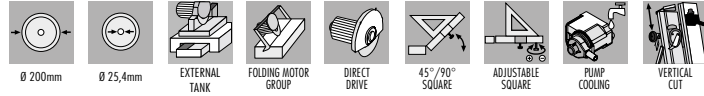

LEM 105 (VERTICAL CUT)



2	426 105	8024648080424	1	LEM 105 with Ø 200 mm (8") diamond disc for porcelain	Single-phase	230 V 50 Hz	0,9	2.200,00
	426 105 US	8024648081254	1	LEM 105 with Ø 200 mm (8") diamond disc for porcelain	Single-phase	110 V 60 Hz	0,9	2.250,00

CUTTING SPECIFICATIONS AND MACHINE DIMENSIONS/WEIGHT

Model										
LEM 105	200 mm 8" mm	40 mm 1 9/32"	30 mm 1 3/16"	105 cm 41 3/8"	∞	75x75 cm 29 1/2" x29 1/2"	170x84xh 55 cm 67"x33"xh 21 1/2"	67 Kg 148 lbs	176x79xh 71 cm 69"x31"xh 28"	92 Kg 203 lbs

TECHNICAL CHARACTERISTICS

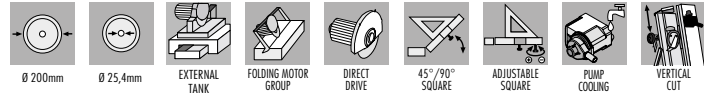

ACCESSORIES AND DIAMOND BLADES FOR LEM 150/LEM 105



	411SE A5	8024648070944	1	Laser with stirrup for LEM 150 / LEM 105		LEM 150	LEM 105	LEM 120	
3	426EP01A	8024648066749	1	Extension side supports for LEM 150 / LEM 105 / LEM 120		•	•	•	195,00
4	179SET200SP	8024648076137	1	Ø 200 mm (8") diamond disc for porcelain for LEM 150 / LEM 105 / LEM 120		•	•	•	118,00
	192SQ03A	8024648014986	1	Sliding square 90° for LEM 120		-	-	•	19,50
	192SQ07A	8024648053893	1	Left sliding square 45°/90° for LEM 120		-	-	•	16,20



**BI-BULL DOG ADV AUTOMATIC**

1



1	428AUT 230	8024648071767	1	Bi-Bull Dog ADV Automatic with "universal" table; without diamond wheel	Single-phase	230 V 50 Hz	1,1	6.400,00
1	428AUT 60	8024648071774	1	Bi-Bull Dog ADV Automatic with "universal" table; without diamond wheel	Single-phase	230 V 60 Hz	1,1	6.500,00
1	428AUT USA	8024648071750	1	Bi-Bull Dog ADV Automatic with "universal" table; without diamond wheel	Single-phase	110 V 60 Hz	1,1	6.640,00
1	428AUT GB	8024648071729	1	Bi-Bull Dog ADV Automatic with "universal" table; without diamond wheel	Single-phase	110 V 50 Hz	1,1	6.640,00

CUTTING SPECIFICATIONS AND MACHINE DIMENSIONS/WEIGHT

Model	Profile											
BI-BULLDOG ADV AUTOMATIC		30 mm 1 3/16"	30 mm 1 3/16"	-	-	-	120 cm	60 cm	222x85xh 105 cm	185 Kg	250x105x h 110 cm	230 Kg
		20 mm 3/4"	20 mm 3/4"	-	-	-						
		15 mm 5/8"	15 mm 5/8"	-	-	-						
		12 mm 15/32"	12 mm 15/32"	-	-	-						
		10 mm 3/8"	10 mm 3/8"	-	-	-	47 1/4"	23 5/8"	87"x33"xh 41"	407.9 lbs	98"x41"x h 43"	507.1 lbs
		8 mm 5/16"	8 mm 5/16"	-	-	-						
		V 45°	-	-	15 mm 5/8"	-						
		90°	30 mm 1 3/16"	-	-	-	-	-	-	-	-	-
	11 mm 7/16"	22 mm 7/8"	-	-	-	-	-	-	-	-	-	-

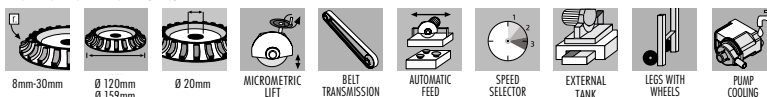
TECHNICAL CHARACTERISTICS**BI-BULL DOG ADV WITH WHEEL KIT FEED**

2



2	428AVOL 230	8024648079350	1	Bi-Bull Dog ADV with wheel kit, "universal" table, without diamond wheel	Single-phase	230V 50Hz	1,1	3.700,00
2	428AVOL 60	8024648079367	1	Bi-Bull Dog ADV with wheel kit, "universal" table, without diamond wheel	Single-phase	230V 60Hz	1,1	3.770,00
2	428AVOL USA	8024648079343	1	Bi-Bull Dog ADV with wheel kit, "universal" table, without diamond wheel	Single-phase	110V 60Hz	1,1	3.860,00
2	428AVOL GB	8024648079329	1	Bi-Bull Dog ADV with wheel kit, "universal" table, without diamond wheel	Single-phase	110V 50Hz	1,1	3.870,00

CUTTING SPECIFICATIONS AND MACHINE DIMENSIONS/WEIGHT

Model	Profile											
BI-BULLDOG ADV WITH WHEEL KIT FEED		30 mm 1 3/16"	30 mm 1 3/16"	-	-	-	120 cm	60 cm	222x85xh 105 cm	152 Kg	250x100x h 135 cm	197 Kg
		20 mm 3/4"	20 mm 3/4"	-	-	-						
		15 mm 5/8"	15 mm 5/8"	-	-	-						
		12 mm 15/32"	12 mm 15/32"	-	-	-						
		10 mm 3/8"	10 mm 3/8"	-	-	-	47 1/4"	23 5/8"	87"x33"xh 41"	335.1 lbs	98"x40"x h 53"	434.3 lbs
		8 mm 5/16"	8 mm 5/16"	-	-	-						
		V 45°	-	-	15 mm 5/8"	-						
		90°	30 mm 1 3/16"	-	-	-	-	-	-	-	-	-
	11 mm 7/16"	22 mm 7/8"	-	-	-	-	-	-	-	-	-	-

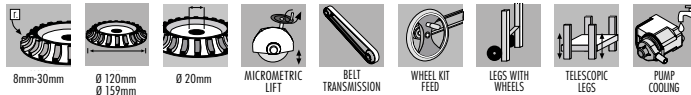
TECHNICAL CHARACTERISTICS**BI-BULL DOG ADV**

3



3	428	8024648005878	1	Bi-Bull Dog ADV with "universal" table without diamond wheel	Single-phase	230V 50Hz	1,1	2.950,00
3	428 60	8024648062093	1	Bi-Bull Dog ADV with "universal" table without diamond wheel	Single-phase	230V 60Hz	1,1	3.000,00
3	428 USA	8024648062086	1	Bi-Bull Dog ADV with "universal" table without diamond wheel	Single-phase	110V 60Hz	1,1	3.140,00
3	428 GB	8024648062079	1	Bi-Bull Dog ADV with "universal" table without diamond wheel	Single-phase	115V 50Hz	1,1	3.140,00

CUTTING SPECIFICATIONS AND MACHINE DIMENSIONS/WEIGHT

Model	Profile											
BI-BULLDOG ADV		30 mm 1 3/16"	30 mm 1 3/16"	-	-	-	120 cm	60 cm	113x80xh 70 cm	136 Kg	120x80xh 100 cm	155 Kg
		20 mm 3/4"	20 mm 3/4"	-	-	-						
		15 mm 5/8"	15 mm 5/8"	-	-	-						
		12 mm 15/32"	12 mm 15/32"	-	-	-						
		10 mm 3/8"	10 mm 3/8"	-	-	-	47 1/4"	23 5/8"	44 1/2"x31 1/2"xh 27 1/2"	299.8 lbs	47"x31 1/2"xh 40"	341.7 lbs
		8 mm 5/16"	8 mm 5/16"	-	-	-						
		V 45°	-	-	15 mm 5/8"	-						
		90°	30 mm 1 3/16"	-	-	-	-	-	-	-	-	-
	11 mm 7/16"	22 mm 7/8"	-	-	-	-	-	-	-	-	-	-

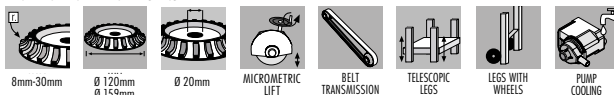
TECHNICAL CHARACTERISTICS

BULL DOG ADV



1	427ADV	8024648058928	1	Bull Dog ADV with "universal" table, radius 10mm (3/8") bullnose wheel	Single-phase	230 V 50 Hz	1,1	2.130,00
1	427ADV 60	8024648060488	1	Bull Dog ADV with "universal" table, radius 10mm (3/8") bullnose wheel	Single-phase	230 V 60 Hz	1,1	2.180,00
1	427ADV USA	8024648060471	1	Bull Dog ADV with "universal" table, radius 10mm (3/8") bullnose wheel	Single-phase	110 V 60 Hz	1,1	2.230,00
1	427ADV GB	8024648060464	1	Bull Dog ADV with "universal" table, radius 10mm (3/8") bullnose wheel	Single-phase	115 V 50 Hz	1,1	2.230,00

CUTTING SPECIFICATIONS AND MACHINE DIMENSIONS/WEIGHT

Model	Profile										
BULLDOG ADV		30 mm 1 3/16"	30 mm 1 3/16"	-	-	80 cm	90x80xh 70 cm	75 Kg	120x80xh 100 cm	94 Kg	
		20 mm 3/4"	20 mm 3/4"	-	-						
		15 mm 5/8"	15 mm 5/8"	-	-						
		12 mm 15/32"	12 mm 15/32"	-	-						
		10 mm 3/8"	10 mm 3/8"	-	-	31 1/2"	23 5/8"	35 1/2" x 31 1/2" x h 27 1/2"	165.3 lbs	47" x 31 1/2" x h 40"	207.2 lbs
		8 mm 5/16"	8 mm 5/16"	-	-						
		V 45°	-	-	15 mm 5/8"						
		90°	30 mm 1 3/16"	-	-						
	11 mm 7/16"	22 mm 7/8"	-	-							

TECHNICAL CHARACTERISTICS

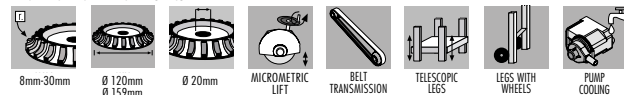

STANDALONE BACK-FINISHER BULLDOG



2	427 BARIRIEU	8024648094407	1	STANDALONE BACK-FINISHER BULLDOG with extensions and table, without table and without diamond wheel	Single-phase	230 V 50 Hz	1,1	1.830,00
2	427 BARIRIBR	8024648094636	1	STANDALONE BACK-FINISHER BULLDOG with extensions and table, without table and without diamond wheel	Single-phase	230 V 60 Hz	1,1	1.855,00
2	427 BARIRIUS	8024648094421	1	STANDALONE BACK-FINISHER BULLDOG with extensions and table, without table and without diamond wheel	Single-phase	110 V 60 Hz	1,1	1.880,00
2	427 BARIRIGB	8024648094414	1	STANDALONE BACK-FINISHER BULLDOG with extensions and table, without table and without diamond wheel	Single-phase	110 V 50 Hz	1,1	1.880,00

CUTTING SPECIFICATIONS AND MACHINE DIMENSIONS/WEIGHT

Model	Profile						
STANDALONE BACK-FINISHER BULLDOG	 	120 cm 47 1/4"	60 cm 23 5/8"	165x75x h 100 cm 65" x 29 1/2" x h 39 3/8"	73 Kg 160.9 lbs	90x72x h 90 cm 35 1/2" x 28 1/8" x h 35 1/2"	88,5 Kg 195.1 lbs

TECHNICAL CHARACTERISTICS

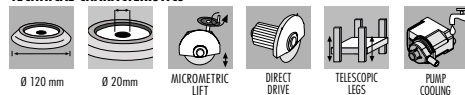

AVAILABLE BLADES



BACK-FINISHER BULLDOG FOR CONNECTION IN LINE



3	427 BARIOHEU	8024648094179	1	BACK-FINISHER BULLDOG FOR CONNECTION IN LINE without extensions without table and without diamond wheel	Single-phase	230 V 50 Hz	1,1	1.070,00
3	427 BARIOHBR	8024648094629	1	BACK-FINISHER BULLDOG FOR CONNECTION IN LINE without extensions without table and without diamond wheel	Single-phase	230 V 60 Hz	1,1	1.095,00
3	427 BARIOHUS	8024648094391	1	BACK-FINISHER BULLDOG FOR CONNECTION IN LINE without extensions without table and without diamond wheel	Single-phase	110 V 60 Hz	1,1	1.120,00
3	427 BARIOHGB	8024648094186	1	BACK-FINISHER BULLDOG FOR CONNECTION IN LINE without extensions without table and without diamond wheel	Single-phase	110 V 50 Hz	1,1	1.120,00

CUTTING SPECIFICATIONS AND MACHINE DIMENSIONS/WEIGHT

Model	Profile						
BACK-FINISHER BULLDOG FOR CONNECTION IN LINE	 	120 cm 47 1/4"	60 cm 23 5/8"	63x75x h 90 cm 25" x 29 1/2" x h 35 1/2"	41 Kg 90 lbs	90x72x h 90 cm 35 1/2" x 28 1/8" x h 35 1/2"	56,5 Kg 124.6 lbs

TECHNICAL CHARACTERISTICS

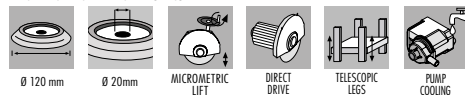

AVAILABLE BLADES

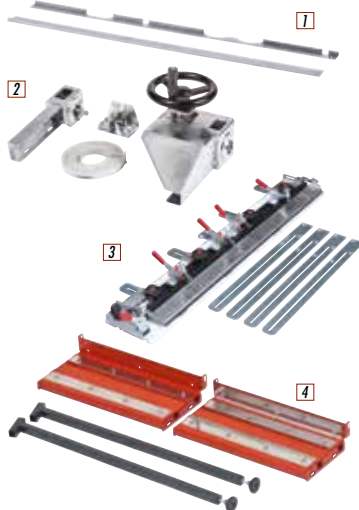

**ACCESSORIES FOR CONNECTING BACK-FINISHER-
BULLDOG TO BULLDOG AND BI-BULLDOG**

7	114TOK05A	8024648061577	1	Guides to connect Back-finisher with Bi-Bulldog Adv - pair	95,00
7	114TOK06A	8024648093219	1	Guides to connect Back-finisher with Bulldog Adv - pair	75,00
	286DT14D	8024648094551	1	Belt for updating wheel-feed-kit (Back-finisher + Bi-Bulldog)	48,00
	286DT15D	8024648094568	1	Belt for updating wheel-feed-kit (Back-finisher + Bulldog)	44,00
2	419AVBU BBRIH	8024648094452	1	Wheel-feed-kit for Back-finisher + Bi-Bulldog	494,00
	419AVBU BURIH	8024648094476	1	Wheel-feed-kit for Back-finisher + Bulldog	490,00
3	039CA00AB	8024648082756	1	"Universal" table for tiles: max length 80 cm (31 1/2")	435,00
3	039CA00ABB	8024648082763	1	"Universal" table for tiles: max length 120 cm (47 1/4")	567,00
4	428PR03A	8024648062161	1	Side extensions for Bulldog Adv, Bi-Bulldog Adv and Back-finisher - pair	205,00

Part No.	BULLDOG ADV	BI-BULLDOG ADV	BULLDOG ADV WITH WHEEL-FEED-KIT	BI-BULLDOG ADV WITH WHEEL-FEED-KIT	BULLDOG ADV AUTO	BI-BULLDOG ADV AUTO	STAND ALONE BACK-FINISHER	BACK-FINISHER FOR CONNECTION				
114TOK05A	-	•	-	•	-	-	-	•	170xØ 10 cm	67"xØ 4 cm	5,8 Kg	12.8 lbs
114TOK06A	•	-	•	-	-	-	-	•	170xØ 10 cm	67"xØ 4 cm	5,2 Kg	11.5 lbs
286DT14D	-	-	-	•	-	-	-	•	-	-	-	-
286DT15D	-	-	•	-	-	-	-	•	-	-	-	-
419AVBU BBRIH	-	•	-	-	-	-	-	•	-	-	-	-
419AVBU BURIH	•	-	-	-	-	-	-	•	-	-	-	-
039CA00AB	standard	-	-	-	-	-	-	•	90x25xh 9cm	35 1/2"x9 7/8"xh 3 1/2"	7,5 Kg	16.5 lbs
039CA00ABB	•*	standard	standard	standard	standard	standard	standard	•	137x25xh 9 cm	54"x9 7/8"xh 3 1/2"	9,5 Kg	21 lbs
428PR03A	•	standard	standard	standard	standard	standard	standard	•	80x33xh 21 cm	31 1/2"x13"xh 8 1/4"	13 Kg	28.6 lbs

* The "universal" table length 120 cm can be mounted on Bull-Dog Adv only in combination with the side extensions (cod.428PR03A)

What machine do I have	Back-finisher for connection	what do I add					What do I obtain
		Guides	Belt	Wheel feed kit	Universal trolley	Side extensions	
Automatic Bi-Bulldog				It is not possible to connect the back-finisher to automatic version			
Bi-Bulldog with wheel-feed-kit	427 BARIOHEU 427 BARIOHBR	114TOK05A	286DT14D	standard	standard	standard	Back-Finisher Bulldog and Bi-Bulldog in line with wheel-feed-kit
Bi-Bulldog manual	427 BARIOHUS 427 BARIOHGB	114TOK05A	-	419AVBU BBRIH	standard	standard	Back-Finisher Bulldog and Bi-Bulldog in line with wheel-feed-kit
Bi-Bulldog manual		114TOK05A	-	standard	standard	standard	Back-Finisher Bulldog and Bi-Bulldog in line with manual feed
Bulldog with wheel-feed-kit	427 BARIOHEU 427 BARIOHBR	114TOK06A	286DT15D	standard	standard	standard	Back-Finisher Bulldog and Bulldog in line with wheel-feed-kit
Bulldog manual	427 BARIOHUS 427 BARIOHGB	114TOK06A	-	419AVBU BURIH	039CA00ABB	438PR03A	Back-Finisher Bulldog and Bulldog in line with wheel-feed-kit
Bulldog manual		114TOK06A	-	standard	standard	standard	Back-Finisher Bulldog and Bulldog in line with manual feed

Given the huge number of variables involved, you should always consult Raimondi experts to verify the correct configuration of the system.

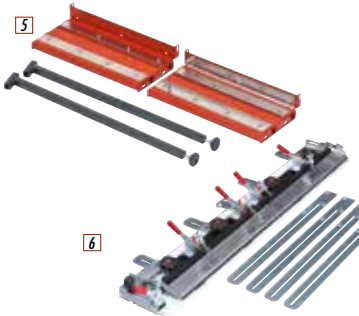
**ACCESSORIES AND SPARE PARTS FOR
BACK-FINISHER AND PROFILING MACHINES**

5	428PR03A	8024648062161	1	Side extensions for Bulldog Adv, Bi-Bulldog Adv and Back-finisher - pair	205,00
	039CA00AB	8024648058553	1	"Universal" table for tiles: max length 80x60 cm; min 80x4 cm	435,00
6	039CA00ABB	8024648082763	1	"Universal" table for tiles: max length 120x60 cm; min 120x4 cm	567,00

* The "universal" table length 120 cm can be mounted on Bull-Dog Adv only in combination with the side extensions (cod.428PR03A)

**MANUAL FEED KIT WITH WHEEL FOR BULLDOG ADV
AND BI-BULLDOG ADV**

7	419AVBU BULL	8024648073785	1	Manual feed kit with wheel for Bulldog Adv	1.290,00
	419AVBU BIBU	8024648073778	1	Manual feed kit with wheel for Bi-Bulldog Adv	1.100,00

**AUTOMATION KIT FOR BULLDOG ADV AND
BI-BULLDOG ADV**

8	429KIT 428	8024648071200	1	Automation kit for Bi-Bulldog Adv 230V 50/60 Hz	3.900,00
8	429KIT 428US	8024648071798	1	Automation kit for Bi-Bulldog Adv 110V 50/60 Hz	3.900,00

**REMOVABLE TANK KIT AND PUMP FOR
BULLDOG ADV AND BI-BULLDOG ADV**

9	429KITVA230	8024648071835	1	Removable tank kit and pump for Bulldog Adv 230V 50 Hz	218,00
	429KITVA220H6	8024648075093	1	Removable tank kit and pump for Bulldog Adv 230V 60 Hz	230,00
	429KITVA110/6	8024648081278	1	Removable tank kit and pump for Bulldog Adv 110V 60Hz	235,00
	429KITVA110	8024648071828	1	Removable tank kit and pump for Bulldog Adv 110V 50 Hz	227,00
	429KITV 230	8024648072108	1	Removable tank kit and pump for Bi-Bulldog Adv 230V 50 Hz	222,00
	429KITV 230BB	8024648071811	1	Removable tank kit and pump for Bi-Bulldog Adv 230V 60 Hz	233,00
	429KITV 110BB	8024648071804	1	Removable tank kit and pump for Bi-Bulldog Adv 110V 50 Hz	233,00
	429KITV 110B6	8024648081261	1	Removable tank kit and pump for Bi-Bulldog Adv 110V 60 Hz	240,00



CONTINUOUS RIM DIAMOND DISCS



7



2



				EXPLOIT	BOLT	MISTRAL	PKIUS ADV	SMS	ZOE ADV	CM	SA80	SA09	SHERPA	GS86	ECO92	SUPERCO98	CM180AUTO	JOLLY ADV	JOLLYNA	LEM105/150		Suitable for		
7	179CC350	8024648004048	1	-	-	•	-	•	•	•	•	•	-	-	-	-	•	-	-	-	350 mm	14"	ceramic	206,50
2	179CC300	8024648004055	1	-	-	•	-	•	•	•	•	•	-	-	-	-	•	-	-	-	300 mm	12"	ceramic	180,00
2	179CC200E	8024648004086	1	•	-	-	-	-	-	-	-	-	-	-	-	-	•	•	•	•	200 mm	8"	ceramic	64,00
2	179CC200	8024648004079	1	•	-	-	-	-	-	-	-	-	-	-	-	•	-	-	-	-	200 mm	8"	ceramic	120,00
7	179CC180	8024648004093	1	•	-	-	-	-	-	-	-	-	-	-	-	-	-	-	-	-	180 mm	7"	ceramic	46,40
2	179CC150	8024648004109	1	-	-	-	-	-	-	-	-	-	-	-	-	•	-	-	-	-	150 mm	6"	ceramic	36,00
2	179CC115	8024648004192	1	-	-	-	-	-	-	-	-	-	-	-	-	-	-	-	-	-	115 mm	4 1/2"	ceramic	69,70
7	179CC250B	8024648004161	2	-	-	-	-	-	-	-	-	-	-	-	-	-	•	-	-	-	250 mm	10"	bisel	198,00

TURBO DIAMOND DISCS



3



4



				EXPLOIT	BOLT	MISTRAL	PKIUS ADV	SMS	ZOE ADV	CM	SA80	SA09	SHERPA	GS86	ECO92	SUPERCO98	CM180AUTO	JOLLY ADV	JOLLYNA	LEM105/150		Suitable for		
3	179CCT350	8024648003980	1	-	-	•	-	•	•	•	•	•	-	-	-	-	•	-	-	-	350 mm	14"	ceramic	316,00
3	179CCT350E	8050532002333	1	-	-	•	-	•	•	•	•	•	-	-	-	-	•	-	-	-	350 mm	14"	building mat.	205,00
3	179CCT300	8024648003997	1	-	-	•	-	•	•	•	•	•	-	-	-	-	•	-	-	-	300 mm	12"	ceramic	253,00
3	179CCT300E	8050532002326	1	-	-	•	-	•	•	•	•	•	-	-	-	-	•	-	-	-	300 mm	12"	building mat.	165,00
3	179CCT250	8024648004000	1	-	•	-	•	-	-	-	-	-	-	-	-	-	-	-	-	-	250 mm	10"	ceramic	186,00
3	179CCT250E	8050532002319	1	-	•	-	•	-	-	-	-	-	-	-	-	-	-	-	-	-	250 mm	10"	building mat.	105,00
4	179CCT125	8024648075703	1	-	-	-	-	-	-	-	-	-	-	-	-	-	-	-	-	-	125 mm	5"	ceramic	55,00
4	179CCT115	8024648004024	1	-	-	-	-	-	-	-	-	-	-	•	-	-	-	-	-	-	115 mm	4 1/2"	ceramic	77,40

SEGMENTED DIAMOND DISC



5



6



7



8



				EXPLOIT	BOLT	MISTRAL	PKIUS ADV	SMS	ZOE ADV	CM	SA80	SA09	SHERPA	GS86	ECO92	SUPERCO98	CM180AUTO	JOLLY ADV	JOLLYNA	LEM105/150		Suitable for		
6	179SET600	8024648059536	1	-	-	-	-	-	-	-	-	-	•	-	-	-	-	-	-	-	630 mm	25"	building mat.	320,00
6	179SET600CF	8024648060761	1	-	-	-	-	-	-	-	-	-	•	-	-	-	-	-	-	-	600 mm	23 5/8"	concrete&steel	445,00
6	179SET500	8024648017925	1	-	-	-	-	-	-	-	-	-	•	-	-	-	-	-	-	-	500 mm	20"	building mat.	290,00
6	179SET400TU	8024648065667	1	-	-	-	-	-	-	-	-	-	•	-	-	-	-	-	-	-	406 mm	16"	tufa	230,00
5	179SET360E	8024648054166	1	-	-	•	-	•	•	•	•	•	-	-	-	-	•	-	-	-	360 mm	14 3/16"	building mat.	140,00
6	179SET300	8024648004130	1	-	-	•	-	•	•	•	•	•	-	-	-	-	•	-	-	-	300 mm	12"	building mat.	204,00
7	179SET350G	8024648005946	1	-	-	•	-	•	•	•	•	•	-	-	-	-	•	-	-	-	350 mm	14"	granite	335,00
7	179SET300G	8024648004147	1	-	-	•	-	•	•	•	•	•	-	-	-	-	•	-	-	-	300 mm	12"	granit	281,00
7	179SET350B	8024648011022	1	-	-	•	-	•	•	•	•	•	-	-	-	-	•	-	-	-	350 mm	14"	porcelain	248,00
8	179SET300B	8024648004154	1	-	-	•	-	•	•	•	•	•	-	-	-	-	•	-	-	-	300 mm	12"	porcelain	234,00
8	179SET300BS	8024648076076	1	-	-	•	-	•	•	•	•	•	-	-	-	-	•	-	-	-	300 mm	12"	porcelain	170,00
8	179SET250SP	8024648080912	1	-	•	-	•	-	-	-	-	-	-	-	-	-	-	-	-	-	250 mm	10"	porcelain	160,00
8	179SET250BE	8024648055002	1	-	•	-	•	-	-	-	-	-	-	-	-	-	-	-	-	-	250 mm	10"	porcelain	97,00
8	179SET200SP	8024648076137	1	•	-	-	-	-	-	-	-	-	-	-	-	-	-	•	•	•	200 mm	8"	porcelain	118,00

DIAMOND WHEELS FOR CHANNEL CUT/ANTI-SLIP GROOVE



9



9	179SCAN4D300	8024648071415	1	Ø 300 mm (12") diamond disc thickness 4 mm (5/32")	Milling	CM180 AUTO	•	230,00
---	---------------------	---------------	---	--	---------	------------	---	---------------

DRESSING/SHARPENING STONES



12

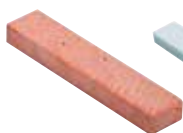

10



10	288	8024648004178	5	30 x 100 x h 15 mm dressing stone for saws and hole cutting machines	2,40
11	288 L	8024648013965	6	30 x 200 x h 10 mm dressing stone for Bulldog Adv - Bi-Bulldog Adv	3,80
12	288YA46	8024648079619	1	Sharpening stone for diamond disc 45x230x25 mm for saws and hole cutting machines	11,00

11

FORACOSTE



7	210F EU	8050532002173	1	Foracoste (without core-drills)	Single-phase	230 V 50/60 Hz	1,1	978,00
----------	----------------	---------------	---	---------------------------------	--------------	----------------	-----	---------------

PERFORMANCE

Model	Diamond Bits Ø	Maximum tile thickness	Minimum tile thickness	Maximum hole depth	Max tile length	Max tile width
FORACOSTE	4 - 12 mm	5/32" - 1/2"	30 mm 1 3/16"	20 mm 13/16"	30 mm 1 3/16"	∞

DIMENSIONS AND WEIGHT

Model	Dimensions	Weight	Dimensions	Weight
210F EU	72x45x h 47 cm	28 3/8"x17 3/4"x 18 1/2"	74x58x h 41 cm	29"x23"x h 16"

TECHNICAL CHARACTERISTICS

ADJUSTABLE SLIDING DEVICE

SECURITY DEVICE

PUMP COOLING

VARIABLE SPEED

SLOT



2	209SLOT 230V	8024648093004	1	Slot with angle grinder with diamond disc Ø 150 mm (6") continuous rim Single-phase	230 V 50/60 Hz	0,9	610,00
3	209SLOT OH	8024648092984	1	Slot without angle grinder with diamond disc Ø 150 mm (6") continuous rim	-	0,9	459,00

PERFORMANCE

Model	Disc	Maximum tile thickness	Minimum tile thickness	Max slot/incision length	Maximum hole depth	Max tile length	Max tile width
SLOT	150 mm 6"	30 mm 1 3/16"	20 mm 13/16"	130 mm 5 1/8"	15 mm 5/8"	∞	∞

DIMENSIONS AND WEIGHT

Model	Weight	Weight	Dimensions	Weight	Weight
209SLOT 230V	9,4 Kg	20.7 lbs	49x39x h 25 cm	10,3 Kg	22.7 lbs
209SLOT OH	6,7 Kg	14.8 lbs	19"x15 1/8"x h 10"	7,6 Kg	16.8 lbs

TECHNICAL CHARACTERISTICS

ACCESSORIES, RELATED PRODUCTS AND DIAMOND TOOLS FOR FORACOSTE AND SLOT



Code	Part No.	Description	FORACOSTE	SLOT	Price
4	209KIT	8024648093523 1 Squares kit + 2 stand alone tile holders for BM180		•	271,00
5	179CC150SE	8024648087171 1 Ø 150 mm (6") continuous rim diamond disc (dry use)	-	•	85,00
6	394MA RAI	8050532000995 1 BM180 modular bench (worktop dim: 180x90cm - 6'x3'; max load 150Kg-331lbs)	•	•	468,00
7	394BLOPIACP	8024648096678 1 Stand alone tile holder for BM180 - pair	•	•	65,00
8	181D12	8024648003942 1 Diamond bit	12 mm	15/32"	39,00
9	181D10	8024648003959 1 Diamond bit	10 mm	13/32"	31,20
10	181D8	8024648003966 1 Diamond bit	8 mm	5/16"	28,90
11	181D6	8024648003973 1 Diamond bit	6 mm	1/4"	26,70
12	181D4	8024648075123 1 Diamond bit	4 mm	5/32"	43,40



RAI-FIX - SAFETY WITH HOLDING HOOK



Code	Part No.	Description	8 mm (5/16")	24x18xh5	Price
13	299	8024648075604 1 Safety with holding stainless steel hook RAI-FIX 70 pcs package	8 mm (5/16")	24x18xh5	87,00
13	299 C120	8024648076267 1 Safety with holding stainless steel hook RAI-FIX 120 pcs box	8 mm (5/16")	27x15xh10	140,00
13	299 C500	8024648078230 1 Safety with holding stainless steel hook RAI-FIX 500 pcs box	8 mm (5/16")	33x23xh17	570,00
13	299 6MM 120	8024648081582 1 Safety with holding stainless steel hook RAI-FIX 120 pcs box	6 mm (0.24") 7,9 mm (0.31")	27x15xh10	140,00
13	299 6MM 500	8024648081681 1 Safety with holding stainless steel hook RAI-FIX 500 pcs box	6 mm (0.24") 7,9 mm (0.31")	33x23xh17	570,00
13	299 5MM 120	8050532002906 1 Safety with holding stainless steel hook RAI-FIX 120 pcs box	5 mm (0.20") 5,9 mm (0.23")	27x15xh10	140,00
13	299 5MM 500	8050532002913 1 Safety with holding stainless steel hook RAI-FIX 500 pcs box	5 mm (0.20") 5,9 mm (0.23")	33x23xh17	570,00

Model	5 mm - 0.20"	5.5 mm - 0.22"	6 mm - 0.24"	6.5 mm - 0.26"	7 mm - 0.28"	7.5 mm - 0.30"	8 mm - 0.31"	> 8 mm - 0.31"
299	-	-	-	-	-	-	•	•
299C120	-	-	-	-	-	-	•	•
299C500	-	-	-	-	-	-	•	•
2996MM120	-	-	•	•	•	•	-	-
2996MM500	-	-	•	•	•	•	-	-
2995MM120	•	•	-	-	-	-	-	-
2995MM500	•	•	-	-	-	-	-	-

RAI-CUT

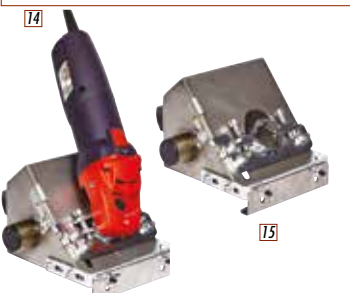

14	299RAICUT UN	8024648088116	1	RAI-CUT - Grooving tool (max thickness 30 mm) for RAI-FIX system with universal angle grinder attachment. Complete angle grinder 850W - 230V 50/60 Hz included	40x40xh15	5,6	299,00
14	299RAICUT110V	8024648077516	1	RAI-CUT - Grooving tool (max thickness 30 mm) for RAI-FIX system with universal angle grinder attachment (Complete angle grinder 850W - 110 50/60 Hz included)	40x40xh15	5,6	299,00
14	299RAICUTGB	8024648083531	1	RAI-CUT - Grooving tool (max thickness 30 mm) for RAI-FIX system with universal angle grinder attachment (Complete angle grinder 850W - 110 50/60 Hz included)	40x40xh15	5,6	309,00
15	299PFLEX UN	8024648087621	1	RAI-CUT frame for RAI-FIX system with universal attachment for angle grinder Supplied without angle grinder.	-	2,2	124,00
	179CCT125	8024648075703	1	Turbo diamond disc Ø 125 mm for RAI-CUT - dry use	-	-	55,00



FORASPEED



1

1 **205F EU** 8050532000834 1 Foraspeed (without core-drills) Single-phase 230V 50/60Hz 1,1 **925,00**

CUTTING SPECIFICATIONS AND MACHINE DIMENSIONS/WEIGHT

Model								
FORASPEED	4 - 120 mm 5/32" - 4 3/4"	30 mm 1 3/16"	35 cm 14"	∞	65x43xh 48 cm 25 1/2"x17"xh 19"	21,1 Kg 46.5 lbs	76x54xh 65 cm 30"x21 1/4"xh 25 1/2"	26,3 Kg 58 lbs

TECHNICAL CHARACTERISTICS



BUCANIERE



2

2 **422** 8024648007629 1 Bucaniere (without core-drills) Single-phase 230V 50Hz 0,6 **870,00**

CUTTING SPECIFICATIONS AND MACHINE DIMENSIONS/WEIGHT

Model								
BUCANIERE	4 - 115 mm 5/32" - 4 1/2"	30 mm 1 3/16"	30 cm 12"	∞	62x32xh 50 cm 24 3/8"x12 5/8"xh 19 5/8"	33 Kg 72.8 lbs	65x35xh 55 cm 25 3/8"x13 3/4"xh 21 5/8"	35 Kg 77.2 lbs

TECHNICAL CHARACTERISTICS

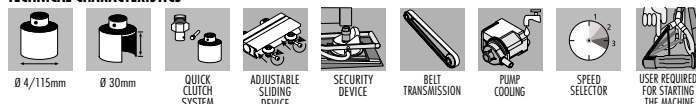

QUICK CHANGE DIAMOND CORE-DRILLS

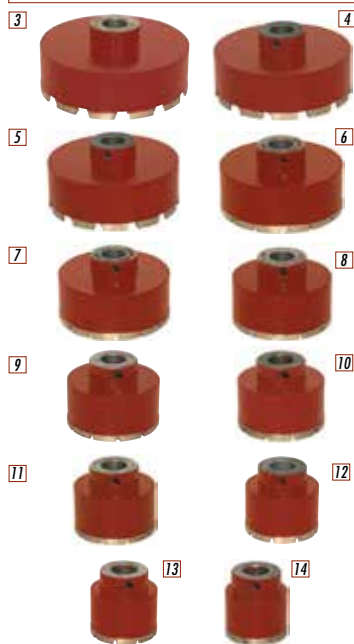

						FORASPEED	BUCANIERE					
3	181D120	8024648006981	1	Quick change diamond core-drill	•	•	•	30 mm	1 3/16"	120 mm	4 3/4"	210,00
4	181D115	8024648010445	1	Quick change diamond core-drill	•	•	•	30 mm	1 3/16"	115 mm	4 1/2"	193,20
5	181D110	8024648010575	1	Quick change diamond core-drill	•	•	•	30 mm	1 3/16"	110 mm	4 3/8"	179,20
6	181D100	8024648006899	1	Quick change diamond core-drill	•	•	•	30 mm	1 3/16"	100 mm	4"	149,80
7	181D90	8024648011237	1	Quick change diamond core-drill	•	•	•	30 mm	1 3/16"	90 mm	3 1/2"	154,00
8	181D85	8024648076229	1	Quick change diamond core-drill	•	•	•	30 mm	1 3/16"	85 mm	3 11/16"	154,00
8	181D80	8024648006974	1	Quick change diamond core-drill	•	•	•	30 mm	1 3/16"	80 mm	3 1/8"	130,20
9	181D75	8024648007049	1	Quick change diamond core-drill	•	•	•	30 mm	1 3/16"	75 mm	3"	123,20
10	181D70	8024648006967	1	Quick change diamond core-drill	•	•	•	30 mm	1 3/16"	70 mm	2 3/4"	114,80
11	181D65	8024648006950	1	Quick change diamond core-drill	•	•	•	30 mm	1 3/16"	65 mm	2 9/16"	109,20
12	181D60	8024648007032	1	Quick change diamond core-drill	•	•	•	30 mm	1 3/16"	60 mm	2 3/8"	103,60
13	181D55	8024648007025	1	Quick change diamond core-drill	•	•	•	30 mm	1 3/16"	55 mm	2 1/8"	98,00
14	181D50	8024648006943	1	Quick change diamond core-drill	•	•	•	30 mm	1 3/16"	50 mm	2"	88,20
15	181D45	8024648007018	1	Quick change diamond core-drill	•	•	•	30 mm	1 3/16"	45 mm	1 3/4"	86,20
16	181D40	8024648006936	1	Quick change diamond core-drill	•	•	•	30 mm	1 3/16"	40 mm	1 5/8"	79,80
17	181D35	8024648006929	1	Quick change diamond core-drill	•	•	•	30 mm	1 3/16"	35 mm	1 3/8"	72,20
18	181D30	8024648006912	1	Quick change diamond core-drill	•	•	•	30 mm	1 3/16"	30 mm	1 3/16"	70,60
19	181D25	8024648006905	1	Quick change diamond core-drill	•	•	•	30 mm	1 3/16"	25 mm	1"	70,60
20	181D22	8024648007001	1	Quick change diamond core-drill	•	•	•	30 mm	1 3/16"	22 mm	7/8"	75,00
21	181D20	8024648006998	1	Quick change diamond core-drill	•	•	•	30 mm	1 3/16"	20 mm	3/4"	75,00

DIAMOND BITS



						FORASPEED	BUCANIERE	FORACOSTE			
22	181D12	8024648003942	1	Diamond bit	•	•	•	•	12 mm	15/32"	39,00
23	181D10	8024648003959	1	Diamond bit	•	•	•	•	10 mm	13/32"	31,20
24	181D8	8024648003966	1	Diamond bit	•	•	•	•	8 mm	5/16"	28,90
25	181D6	8024648003973	1	Diamond bit	•	•	•	•	6 mm	1/4"	26,70
26	181D4	8024648075123	1	Diamond bit	•	•	•	•	4 mm	5/32"	43,40

ADAPTER FOR DIAMOND CORE-DRILLS AND BITS



						FORASPEED	BUCANIERE		
27	181ADATT	8024648011428	1	Adapter for diamond core-drills and bits	•	•	•		14,90
28	181SPINA	8024648011435	1	Core-bit locking pin	•	•	•		4,30

DIAMOND CORE-BITS FOR DRY-DRILLING



1	181S75	8024648057297	1	For grinder (14MA screw attachment)
2	181S65	8024648057280	1	For grinder (14MA screw attachment)
3	181S60	8024648057273	1	For grinder (14MA screw attachment)
4	181S50	8024648057266	1	For grinder (14MA screw attachment)
5	181S40	8024648057259	1	For grinder (14MA screw attachment)
6	181S35	8024648057242	1	For grinder (14MA screw attachment)
7	181S27	8024648057235	1	For grinder (14MA screw attachment)
8	181S20	8024648057228	1	For grinder (14MA screw attachment)
9	181S14	8024648057211	1	For grinder (14MA screw attachment)
10	181S12	8024648057204	1	For grinder (14MA screw attachment)
11	181S10	8024648057198	1	For grinder (14MA screw attachment)
12	181S08	8024648057181	1	For grinder (14MA screw attachment)
13	181S06	8024648057174	1	For grinder (14MA screw attachment)

75 mm	3"	35 mm	1 3/8"	186,90
65 mm	2 9/16"	35 mm	1 3/8"	173,50
60 mm	2 3/8"	35 mm	1 3/8"	166,20
50 mm	2"	35 mm	1 3/8"	134,70
40 mm	1 5/8"	35 mm	1 3/8"	117,90
35 mm	1 3/8"	35 mm	1 3/8"	107,30
27 mm	1 1/16"	35 mm	1 3/8"	89,50
20 mm	3/4"	35 mm	1 3/8"	71,60
14 mm	9/16"	35 mm	1 3/8"	54,80
12 mm	1/2"	35 mm	1 3/8"	49,50
10 mm	3/8"	35 mm	1 3/8"	43,30
8 mm	5/16"	35 mm	1 3/8"	43,00
6 mm	1/4"	35 mm	1 3/8"	42,70



DIAMOND CORE-BITS FOR HUMID DRILLING



14	181U100	8024648068514	1	For drill (shaft attachment Ø 10 mm – 3/8")
15	181U090	8024648068507	1	For drill (shaft attachment Ø 10 mm – 3/8")
16	181U075	8024648068491	1	For drill (shaft attachment Ø 10 mm – 3/8")
	181U070	8024648073525	1	For drill (shaft attachment Ø 10 mm – 3/8")
	181U065	8024648073518	1	For drill (shaft attachment Ø 10 mm – 3/8")
	181U060	8024648073501	1	For drill (shaft attachment Ø 10 mm – 3/8")
	181U055	8024648076748	1	For drill (shaft attachment Ø 10 mm – 3/8")
17	181U050	8024648068484	1	For drill (shaft attachment Ø 10 mm – 3/8")
18	181U045	8024648068477	1	For drill (shaft attachment Ø 10 mm – 3/8")
	181U040	8024648073334	1	For drill (shaft attachment Ø 10 mm – 3/8")
19	181U035	8024648068460	1	For drill (shaft attachment Ø 10 mm – 3/8")
	181U030	8024648076731	1	For drill (shaft attachment Ø 10 mm – 3/8")
20	181U025	8024648068453	1	For drill (shaft attachment Ø 10 mm – 3/8")
21	181U020	8024648068446	1	For drill (shaft attachment Ø 10 mm – 3/8")
22	181U012	8024648068439	1	For drill (shaft attachment Ø 10 mm – 3/8")
23	181U010	8024648068422	1	For drill (shaft attachment Ø 10 mm – 3/8")
24	181U008	8024648068415	1	For drill (shaft attachment Ø 10 mm – 3/8")
25	181U006	8024648068408	1	For drill (shaft attachment Ø 10 mm – 3/8")

100 mm	4"	22 mm	7/8"	109,00
90 mm	3 1/2"	22 mm	7/8"	95,60
75 mm	3"	22 mm	7/8"	80,30
70 mm	2 3/4"	22 mm	7/8"	73,50
65 mm	2 9/16"	22 mm	7/8"	67,00
60 mm	2 3/8"	22 mm	7/8"	60,00
55 mm	2 3/16"	22 mm	7/8"	56,00
50 mm	2"	22 mm	7/8"	43,60
45 mm	1 3/4"	22 mm	7/8"	43,00
40 mm	1 5/8"	22 mm	7/8"	42,40
35 mm	1 3/8"	22 mm	7/8"	36,30
30 mm	1 3/16"	22 mm	7/8"	35,00
25 mm	1"	22 mm	7/8"	30,80
20 mm	3/4"	22 mm	7/8"	17,50
12 mm	1/2"	22 mm	7/8"	16,80
10 mm	3/8"	22 mm	7/8"	12,60
8 mm	5/16"	22 mm	7/8"	10,00
6 mm	1/4"	22 mm	7/8"	8,40





IPERBET

7



7	110	8024648003331	1	Iperbet with 2 buckets 45 litres	Single-phase 230V 50/60 Hz	0,37	710,00
7	110 USA	8024648014092	1	Iperbet with 2 buckets 45 litres	Single-phase 115V 60 Hz	0,37	740,00
7	110 GB	8024648005403	1	Iperbet with 2 buckets 45 litres	Single-phase 115V 50 Hz	0,37	740,00

CUTTING SPECIFICATIONS AND MACHINE DIMENSIONS/WEIGHT

Model				
IPERBET	60x51xh 77 cm	23 5/8" x 19 5/8" xh 30 5/8"	34 Kg 75 lbs	85x60xh 60 cm 33 1/2" x 23 5/8" xh 23 5/8" 39 Kg 86 lbs

TECHNICAL CHARACTERISTICS

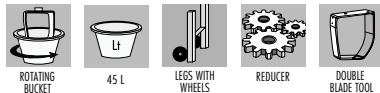

IPERBET FLUID

2



2	110 FLUID	8024648011374	1	Iperbet with 2 buckets 45 litres (12 gal) for fluid materials	Single-phase 230V 50/60 Hz	0,37	820,00
2	110 FLUUS	8024648014948	1	Iperbet with 2 buckets 45 litres (12 gal) for fluid materials	Single-phase 115V 60 Hz	0,37	850,00
2	110 FLUGB	8024648014955	1	Iperbet with 2 buckets 45 litres (12 gal) for fluid materials	Single-phase 115V 50 Hz	0,37	850,00

CUTTING SPECIFICATIONS AND MACHINE DIMENSIONS/WEIGHT

Model				
IPERBET FLUID	60x51xh 77 cm	23 5/8" x 19 5/8" xh 30 5/8"	35 Kg 77 lbs	85x60xh 60 cm 33 1/2" x 23 5/8" xh 23 5/8" 40 Kg 88 lbs

TECHNICAL CHARACTERISTICS



ACCESSORIES AND BUCKETS



3	239KITC01A	8024648007094	1	Tool kit for mixing fluid	IPERBET	IPERBET FLUID	CICO-MIX	158,00
4	239UF02D	8024648011442	1	Double bladed tool	•	standard	–	49,00
5	239VG02A	8050532003774	1	Mass (clump) breaker	•	–	–	14,40
6	289IPER	8024648000989	1	Bucket 45 litres (12 gal) with handles	standard	standard	–	13,70
7	289CICO	8024648007605	1	Bucket 27 litres (7 gal) without handles	–	–	•	17,50



MX2 - MIXER WITH TWO VARIABLE SPEEDS



8	301W1400V2V	8050532000902	1	Mixer 1400W with mixing paddle Ø 140 mm (5 3/4")	180/700 g/min	Single-phase 230V 50/60Hz	1,4	137,00
8	301W1600V2V	8024648017857	1	Mixer 1600W with mixing paddle Ø 160 mm (6 5/16")	300/700 g/min	Single-phase 230V 50/60Hz	1,4	147,00

DIMENSIONS/WEIGHT

Model				
301W1600V2V 301W1400V2V	46x29xh 35 cm	18" x 11 13/32" xh 13 3/4"	5,8 Kg 12.8 lbs	60x30xh 33 cm 23 5/8" x 11 7/8" xh 13" 6,8 Kg 15 lbs

TECHNICAL CHARACTERISTICS

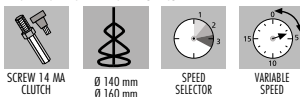

DIGITAL MIXER WITH DIGITAL CONTROL OF MIXING SPEED AND TIME



70	301W1400CDUS	8024648075444	1	Digital mixer 1400W w/mixing paddle Ø 140 mm (5 3/4")	180/700 g/min	Single-phase 120V 60Hz	1,4	185,00
70	301W1400CDGB	8024648085917	1	Digital mixer 1400W w/mixing paddle Ø 140 mm (5 3/4")	180/700 g/min	Single-phase 120V 50Hz	1,4	190,00

DIMENSIONS/WEIGHT

Model				
301W1400CDUS 301W1400CDGB	46x29xh 35 cm	18" x 11 13/32" xh 13 3/4"	5,8 Kg 12.8 lbs	60x30xh 33 cm 23 5/8" x 11 7/8" xh 13" 6,8 Kg 15 lbs

TECHNICAL CHARACTERISTICS

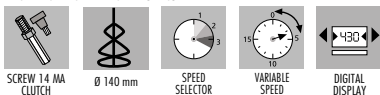

FLUID MIX SPECIAL

1	238 UN	8024648061096	1	Fluid mix special with paddle; without mixer	450,00
----------	---------------	---------------	----------	--	---------------



DIMENSIONS/WEIGHT

Model				
FLUID MIX SPECIAL	61x66xh 95 cm	24"x26"xh 37 1/2"	28 Kg	61.7 lbs
			85x60xh 70 cm	33 1/2"x23 5/8"xh 27 1/2"
			29 Kg	63.9 lbs

TECHNICAL CHARACTERISTICS



FLUID MIX

2	238 EUN	8024648061089	1	Fluid mix with paddle; without mixer	325,00
----------	----------------	---------------	----------	--------------------------------------	---------------



DIMENSIONS/WEIGHT

Model				
FLUID MIX	54x60xh 77cm	21 1/4"x23 1/2"xh 30 3/8"	17 Kg	37.5 lbs
			85x60xh 75 cm	33 1/2"x23 5/8"xh 27 1/2"
			18 Kg	39.7 lbs

TECHNICAL CHARACTERISTICS



SPARE PARTS AND ACCESSORIES FOR FLUID MIX SPECIAL AND FLUID MIX

3	238 CV01A	8024648024299	1	Conveyor for Fluid mix special bucket	105,00
	289LT75	8024648061089	1	Bucket 75 lt (20 gal)	39,00
	178389H	8024648001603	1	Mixing paddle 3 spirals (14MA screw)	29,00

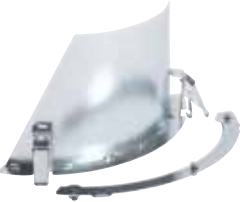

HEIGHT-ADJUSTABLE RAKE FOR SELF-LEVELING

4	243	8024648070968	3	Height-adjustable rake for self-leveling (without handle)	48,50
	243PE01A	8024648073297	1	Spare tempered pivots Ø 4 mm (5/32"); length 60 mm (2 3/8") - 24 pcs kit	26,00



MIXING PADDLES

5	6									
		178 389E	8024648009814	1	4 Bladed mixing paddle (14MA screw)	Ø				
		178 389F	8024648017888	1	2 Bladed mixing paddle (14MA screw)	140 mm	-	•	-	16,00
		178 389G	8024648017895	1	2 Bladed mixing paddle (14MA screw)	140 mm	-	•	-	26,00
		178 389H	8024648017895	1	2 Bladed mixing paddle (14MA screw)	120 mm	-	•	-	22,00
		178 389L	8024648079541	1	2 Bladed mixing paddle (14MA screw)	160 mm	-	•	-	27,00





MOLOSSO



7

7	350R9 UE	8024648093820	1	Molosso	ⓘ	Single-phase 230V 50/60 Hz	0.66	90x72xh 63	99	1.750,00
7	350R9 US	8024648094094	1	Molosso		Single-phase 110V 60 Hz	0.66	90x72xh 63	99	1.790,00
7	350R9 GB	8024648096029	1	Molosso		Single-phase 110V 50 Hz	0.66	90x72xh 63	99	1.800,00

TECHNICAL CHARACTERISTICS



65x53 cm

36 ROLLERS

TELESCOPIC HANDLE

SPARE ROLLER

200M002A 8024648095084 1 Complete rollers kit for Molosso



65x53 cm

81x68xh22

35

476,00

MASTINO



2

2	349	8024648004314	1	Mastino 3 speeds	ⓘ	Single-phase	230/42V 50 Hz	250	60x60xh 34 + 59 100x50xh 12	1.470,00
2	349GB	8024648009425	1	Mastino 3 speeds		Single-phase	110/42V 50 Hz	250	60x60xh 34 + 59 100x50xh 12	1.520,00
2	349US	8024648089670	1	Mastino 3 speeds		Single-phase	110/42V 60 Hz	250	60x60xh 34 + 59 100x50xh 12	1.520,00

TECHNICAL CHARACTERISTICS

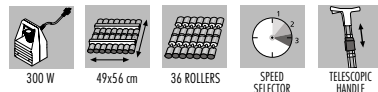

300 W

49x56 cm

36 ROLLERS

SPEED SELECTOR

TELESCOPIC HANDLE

SPARE ROLLER

200MA01A 8024648013217 1 Complete rollers kit for Mastino



49x56 cm

53x53xh 10

29

377,00

TERRANOVA



3

3	105	8024648004321	1	Terranova 3 speeds	ⓘ	Single-phase	230/42V 50/60 Hz	200	80x50xh 30	49	1.310,00
3	105USA	8024648009456	1	Terranova 3 speeds		Single-phase	110/42V 50/60 Hz	200	80x50xh 30	49	1.365,00

TECHNICAL CHARACTERISTICS

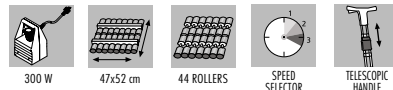

300 W

47x52 cm

44 ROLLERS

SPEED SELECTOR

TELESCOPIC HANDLE

SPARE ROLLER

200TE01A 8024648013330 1 Complete rollers kit for Terranova



47x52 cm

53x53xh 10

22

248,00

VOLPINO



1	321 UE2	8050532000391	1	Volpino compact vibrator for large format tiles	Single-phase 230V/50Hz		25	58x30xh 25	7	450,00
1	321 US2	8050532000407	1	Volpino compact vibrator for large format tiles	Single-phase 110V/60Hz		25	58x30xh 25	7	460,00
1	321 GB2	8050532000414	1	Volpino compact vibrator for large format tiles	Single-phase 110V/50Hz		25	58x30xh 25	7	460,00

LUPETTO



2	116CC EU	8024648084668	1	Lupetto 2 speeds	Single-phase 230/42V 50/60Hz		80	60x30xh 25	11,8	680,00
2	116CC US	8024648084675	1	Lupetto 2 speeds	Single-phase 110/42V 50/60Hz		80	60x30xh 25	11,8	710,00
2	116CC GB	8024648086709	1	Lupetto 2 speeds	Single-phase 110/42V 50Hz		90	60x30xh 25	11,8	715,00

TECHNICAL CHARACTERISTICS

150 W	25x45 cm	SPEED SELECTOR

SPARE ROLLER

200LU01A	8024648014467	1	Complete rollers kit for Lupetto		45x25 cm	50x30xh20	14	250,00
-----------------	---------------	---	----------------------------------	--	----------	-----------	----	---------------

SPRINTBETON

3	104CC EU	8024648084521	1	Sprintbeton supplied with:	Single-phase 230/42V 50/60Hz		90	62x42xh36+ 210x10xh10	27,7	1.155,00
3	104CC US	8024648084613	1	Sprintbeton supplied with:	Single-phase 110/42V 50/60Hz		90	62x42xh36+ 210x10xh10	27,7	1.175,00

					HEIGHT (cm)	THICKNESS (cm)	LENGTH (cm)			
4	146ST01D	8024648013774	1	Aluminium bar	180	2,2	7,6	180x8xh3	2,3	36,50
4	146ST02D	8024648013781	1	Aluminium bar	210	2,2	7,6	210x8xh4	2,7	40,50
4	146ST03D	8024648013798	1	Aluminium bar	250	2,2	7,6	250x8xh5	3,2	45,50
4	146ST04D	8024648013804	1	Aluminium bar	300	2,2	7,6	300x8xh5	3,8	51,80
5	145	8024648004840	1	Steel shim 200 cm	-	2,2	7,6	200x8xh3	6	6,00
6	211	8024648013767	1	Complete vibrating plate 30x45 cm	-	2,2	7,6	58x30xh25	5,9	153,00
6	258BR01D	8024648013828	1	Spare plate 30x45 cm	-	2,2	7,6	58x30xh25	1,8	57,00

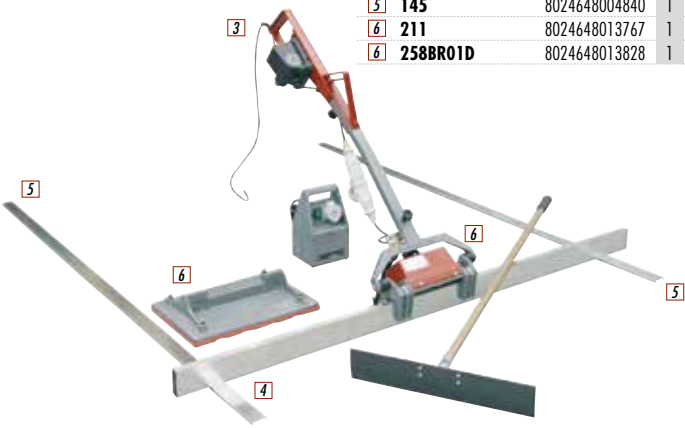

TECHNICAL CHARACTERISTICS

150 W	INTERCHANGEABLE BAR	SPEED SELECTOR

IPERTITINA PLUS



7	108 BIL110	8024648000767	1	Ipertitina Plus 	110	Single-phase	230 V 50 Hz	2,2	81x68xh 64	74	2.190,00
7	108 BIL110H6	8024648053718	1	Ipertitina Plus	132	Single-phase	230 V 60 Hz	2,2	81x68xh 64	74	2.300,00
7	108 BIL110GB	8024648000781	1	Ipertitina Plus	110	Single-phase	110 V 50 Hz	1,8	81x68xh 64	74	2.300,00

TECHNICAL CHARACTERISTICS



IPERTITINA



2	108 110DK	8024648037350	1	Ipertitina 	110	Single-phase	230 V 50 Hz	2,2	70x85xh 60	56	1.840,00
2	108 110H6	8024648015242	1	Ipertitina	132	Single-phase	230 V 60 Hz	2,2	70x85xh 60	56	1.890,00
2	108 110GB	8024648015266	1	Ipertitina	110	Single-phase	110 V 50 Hz	1,8	70x85xh 60	56	1.890,00

TECHNICAL CHARACTERISTICS

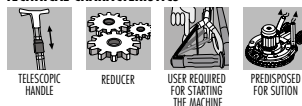

MICROTITINA



3	206	8024648006561	1	Levigatrice Microtitina 	4500	Single-phase	230 V 50 Hz	1,1	75x50xh 43	26	840,00
3	206 110US	8024648065971	1	Levigatrice Microtitina	5400	Single-phase	110 V 60 Hz	1	75x50xh 43	26	870,00
3	206 110GB	8024648065964	1	Levigatrice Microtitina	4500	Single-phase	115 V 50 Hz	1	75x50xh 43	26	880,00

TECHNICAL CHARACTERISTICS

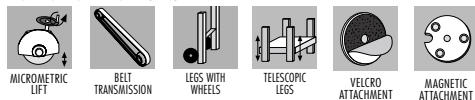

MEGATITINA



4	334 HT230V	8050532005921	1	Megatitina 230V 	1400	Single-phase	230 V 50 Hz	2,5	90,5x72,5 h89	83	2.170,00
5	334 HT400V	8050532005938	1	Megatitina 400V 	1400	Three-phase	400 V 50 Hz	3	90,5x72,5 h89	86	2.380,00

TECHNICAL CHARACTERISTICS MEGATITINA 230V

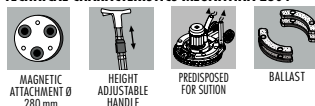

TECHNICAL CHARACTERISTICS MEGATITINA 400V

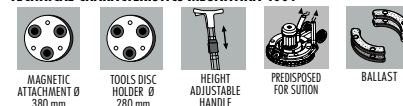



ACCESSORIES FOR FLOOR PREPARATION MACHINES



1	103PL	8024648015310	1	16 liters (4.2 gal) polyethylene tank
2	121IP01A	8024648015327	1	Suction ring
3	121IP03A	8024648057068	1	Lexan splash ring
4	361ASP3V	8024648015594	1	Connector Ø 50/40/40mm for vacuum hose
5	361ASP2V	8024648017376	1	2 ways connector for suction
6	361TUD40C	8024648015600	2	Vacuum hose Ø 40 mm, 65 cm length
7	108GH02D	8024648015341	2	6 Kg (13.2 lbs) (each) side ballast
8	103 M	8024648064417	1	Polypropylene tank 12 liters (3,17 gal)
9	219ZV01A	8024648064578	1	Ballasts Kit 5,9 Kg (13 lbs)
10	206FE01A	8024648064035	1	Adapter for tools with 14MA screw attachment
11	501PD02A	8024648065285	1	Ø 103 mm disc velcro/mousse
12	108KITBAS	8024648000798	1	Kit/trolley for transforming Iperitina Plus into Iperitina Plus

	IPERTITINA PLUS	IPERTITINA	MAXITITINA	SUPERITITINA	MICROITITINA	MEGATITINA			
	•	•	•	•	•	•	62x42xh36	7	118,00
	•	•	•	•	•	•	68x68xh10	1,7	96,00
	•	•	•	•	•	•	66x66xh10	1,7	98,00
	•	•	•	•	•	•	33x33xh10	1	23,50
	•	•	•	•	•	•	-	0,4	52,60
	•	•	•	•	•	•	-	1	2,50
	•	•	•	•	•	•	33x33xh10	13	64,50
	•	•	•	•	•	•	58x30xh37	4	116,00
	•	•	•	•	•	•	-	6,3	85,00
	•	•	•	•	•	•	-	0,7	51,00
	•	•	•	•	•	•	-	0,4	38,00
	•	•	•	•	•	•	81x68xh64	39	525,00



FREE FLOATING AND GEARED PLANETARY TOOLS

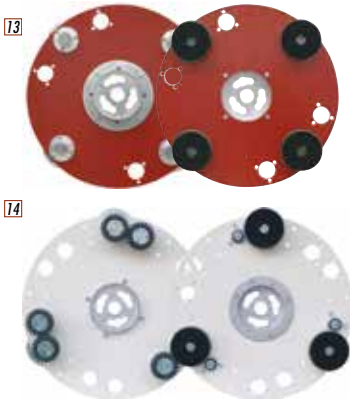

13	250PL4FO	8024648015532	1	Planetary with 4 free floating satellites
14	250PL3MONN	8024648066725	1	Planetary with 3 geared satellites (rpm x5) - left & right
15	250PL6MONN	8024648066732	1	Planetary with 6 geared satellites (rpm x5) - left & right
16	501PD01A	8024648015570	1	Ø 100 mm velcro/mousse disc holder
17	501MV01C	8024648015587	1	Ø 100 mm disc velcro/mousse

	IPERTITINA PLUS	IPERTITINA	MAXITITINA	SUPERITITINA	MICROITITINA	MEGATITINA			
	•	•	•	•	•	•	54x54xh10	9	369,00
	•	•	•	•	•	•	54x54xh10	13	668,00
	•	•	•	•	•	•	54x54xh10	16	990,00
	•	•	•	•	•	•	-	0,4	10,30
	•	•	•	•	•	•	-	0,1	5,90

ABRASIVE PADS WITH VELCRO



18	274CV100G24	8024648015617	24	Abrasive pads made of zirconium with Velcro
18	274CV100G40	8024648015624	24	Abrasive pads made of zirconium with Velcro
18	274CV100G60	8024648015631	24	Abrasive pads made of zirconium with Velcro
18	274CV100G80	8024648015648	24	Abrasive pads made of zirconium with Velcro
18	274CV100G100	8024648015938	24	Abrasive pads made of zirconium with Velcro
18	274CV100G120	8024648015655	24	Abrasive pads made of zirconium with Velcro

mm	IPERTITINA PLUS	IPERTITINA	MAXITITINA	SUPERITITINA	MICROITITINA	MEGATITINA			
115	•	•	•	•	•	•	24	-	0,5
115	•	•	•	•	•	•	40	-	0,5
115	•	•	•	•	•	•	60	-	0,4
115	•	•	•	•	•	•	80	-	0,4
115	•	•	•	•	•	•	100	-	0,3
115	•	•	•	•	•	•	120	-	0,3

DISC HOLDER FOR DIAMOND SEGMENTS

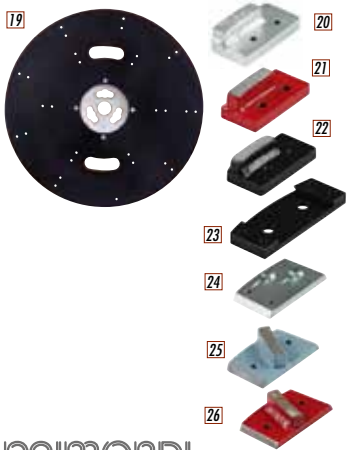

19	250PSDA	8024648060259	1	Disc holder for diamond segments *
20	250P24G	8024648060266	12	Diamond segment 10x40xh 8 mm
21	250P48R	8024648060754	12	Diamond segment 10x40xh 8 mm
22	250P200N	8024648074591	12	Diamond segment 10x40xh 8 mm
23	250P01D	8024648075550	3	Frankfurt holder
24	250P01PCD	8024648076809	3	Polycrystalline tool Frankfurt 37x70xh 6mm
25	250P01P24G	8050532003835	3	Diamond segment Frankfurt 37x70xh 6mm
26	250P01P48R	8050532005914	3	Diamond segment Frankfurt 37x70xh 6mm

mm	IPERTITINA PLUS	IPERTITINA	MAXITITINA	SUPERITITINA	MICROITITINA	MEGATITINA			
530	•	•	•	•	•	•	54x54xh10	7,2	92,00
-	•	•	•	•	•	•	24	12x12xh7	4,0
-	•	•	•	•	•	•	48	12x12xh7	4,0
-	•	•	•	•	•	•	200	12x12xh7	4,0
-	•	•	•	•	•	•	-	7x7xh11	0,2
-	•	•	•	•	•	•	-	7x7xh11	0,4
-	•	•	•	•	•	•	24	7x7xh11	0,5
-	•	•	•	•	•	•	48	7x7xh11	0,5

*segments not included.

**METAL BONDED DIAMOND PAD
MAGNETIC QUICK ATTACHMENT**

1	274DG040/050	8024648056832	3	Metal bonded diamond pad	40/50	115 mm - 4 1/2"	•	•	•	•	•	•	•
2	274DG100/120	8024648056849	3	Metal bonded diamond pad	100/120	115 mm - 4 1/2"	•	•	•	•	•	•	•
3	274DM040/050	8024648056979	3	Metal bonded diamond pad	40/50	115 mm - 4 1/2"	•	•	•	•	•	•	•
4	274DM100/120	8024648057976	3	Metal bonded diamond pad	100/120	115 mm - 4 1/2"	•	•	•	•	•	•	•
5	274DC040/050	8024648056818	3	Metal bonded diamond pad	40/50	115 mm - 4 1/2"	•	•	•	•	•	•	•
6	274DC100/120	8024648056825	3	Metal bonded diamond pad	100/120	115 mm - 4 1/2"	•	•	•	•	•	•	•

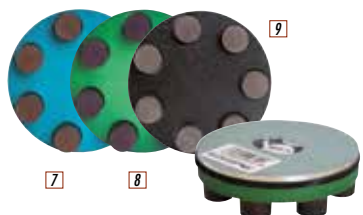
**CERAMIC BONDED DIAMOND PAD MAGNETIC QUICK
ATTACHMENT - CR TYPE**

7	274DTCR0030	8024648057570	3	Ceramic bonded diamond pad CR	30	115 mm - 4 1/2"	•	•	•	•	•	•	•
8	274DTCR0075	8024648057587	3	Ceramic bonded diamond pad CR	75	115 mm - 4 1/2"	•	•	•	•	•	•	•
9	274DTCR0150	8024648057594	3	Ceramic bonded diamond pad CR	150	115 mm - 4 1/2"	•	•	•	•	•	•	•

**RESIN BONDED DIAMOND PAD MAGNETIC QUICK
ATTACHMENT - EPK TYPE**

10	274DTPK0050	8024648057600	3	Resin bonded diamond pad EPK	50	115 mm - 4 1/2"	•	•	•	•	•	•	•
11	274DTPK0120	8024648057617	3	Resin bonded diamond pad EPK	120	115 mm - 4 1/2"	•	•	•	•	•	•	•
12	274DTPK0220	8024648057624	3	Resin bonded diamond pad EPK	220	115 mm - 4 1/2"	•	•	•	•	•	•	•
13	274DTPK0400	8024648057631	3	Resin bonded diamond pad EPK	400	115 mm - 4 1/2"	•	•	•	•	•	•	•
14	274DTPK0600	8024648057648	3	Resin bonded diamond pad EPK	600	115 mm - 4 1/2"	•	•	•	•	•	•	•
15	274DTPK0800	8024648057655	3	Resin bonded diamond pad EPK	800	115 mm - 4 1/2"	•	•	•	•	•	•	•
16	274DTPK1800	8024648057662	3	Resin bonded diamond pad EPK	1800	115 mm - 4 1/2"	•	•	•	•	•	•	•
17	274DTPK3500	8024648057679	3	Resin bonded diamond pad EPK	3500	115 mm - 4 1/2"	•	•	•	•	•	•	•

**RESIN BONDED DIAMOND PAD MAGNETIC QUICK
ATTACHMENT - EPR TYPE**

18	274DTPR0030	8024648057686	3	Resin bonded diamond pad EPR	30	115 mm - 4 1/2"	•	•	•	•	•	•	•
19	274DTPR0080	8024648057693	3	Resin bonded diamond pad EPR	80	115 mm - 4 1/2"	•	•	•	•	•	•	•
20	274DTPR0180	8024648057709	3	Resin bonded diamond pad EPR	180	115 mm - 4 1/2"	•	•	•	•	•	•	•
21	274DTPR0600	8024648057716	3	Resin bonded diamond pad EPR	600	115 mm - 4 1/2"	•	•	•	•	•	•	•
22	274DTPR1800	8024648057723	3	Resin bonded diamond pad EPR	1800	115 mm - 4 1/2"	•	•	•	•	•	•	•

LIQUIDS & POWDERS

23	130CRISTB5LT	8024648074676	1	Water based crystallizing liquid marble and cement	(Can 5 lt / 1.32 gal)			35x27xh31	6,5	60,00
24	130CRISTPG	8024648057952	1	Polishing powder - granite	(Bucket 5 Kg / 11 lbs)			26x26xh26	5	115,00
24	130CRISTPM	8024648057969	1	Polishing powder - marble and concrete	(Bucket 5 Kg / 11 lbs)			26x26xh26	5	115,00
23	130IND ASLT	8024648086914	1	Hardening liquid cement	(Can 5 lt / 1.32 gal)			35x27xh31	6,5	108,00

MAXITITINA

1



1	219	8024648004697	1	Maxititina	Single-phase	230 V	50 Hz	0,9	75x50xh 43	29	980,00
1	219GB110	8024648004727	1	Maxititina	Single-phase	110 V	50 Hz	0,9	75x50xh 43	29	1.040,00
1	219US115	8024648004734	1	Maxititina	Single-phase	110 V	60 Hz	0,9	75x50xh 43	29	1.040,00

TECHNICAL CHARACTERISTICS

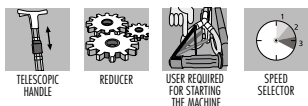

SUPERTITINA

2



2	122	8024648004680	1	Supertitina	Single-phase	230 V	50 Hz	0,6	75x50xh 43	26	930,00
2	122 60HZ	8024648006547	1	Supertitina	Single-phase	230 V	60 Hz	0,6	75x50xh 43	26	970,00
2	122GB110	8024648004703	1	Supertitina	Single-phase	110 V	50 Hz	0,6	75x50xh 43	26	970,00

TECHNICAL CHARACTERISTICS



TANK AND BALLASTS (ACCESSORIES)

3



3	103 SM	8024648058454	1	12 liters (3.2 gal) polyethylene tank					58x30xh 38	3,8	118,00
4	219ZV00A	8024648058485	1	6,8 Kg (15 lbs) (each) side ballast					39x39xh 15	7,5	80,00
5	219ZV02D	8024648058508	1	3,5 Kg (7.7 lbs) extra side ballast					33x33xh 10	4	43,00

	IPERTITINA PLUS	IPERTITINA	MAXITITINA	SUPERTITINA	MICROTTITINA	MEGATITINA
	-	-	-	•	•	-

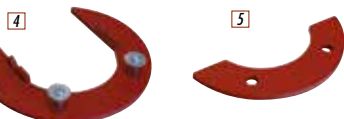



DISCS WITH SILICON CARBIDE ABRASIVE GRINDSTONES



Ref.	Part No.	Description	Gr.	mm	Inch	Series					cm	Kg	Price			
						IPERTINA PLUS	IPERTINA	MAXITINA	SUPERTINA	MICROITINA				MEGATINA		
1	250 IPER	8024648015990	1	Disc with 5 silicon carbide grindstone	Gr. 16	490 mm	19 1/4"	•	•	-	-	-	-	54x54xh 10	10	135,00
1	250	8024648003126	1	Disc with 5 silicon carbide grindstone	Gr. 16	490 mm	19 1/4"	-	-	•	-	-	-	47x47xh 9	10	118,70
2	230	8024648003133	1	Disc with 3 silicon carbide grindstone	Gr. 16	420 mm	16 1/2"	-	-	-	•	-	-	47x47xh 9	7	95,00

1

2

DISCS WITH SILICON CARBIDE ABRASIVE FLAP DISCS

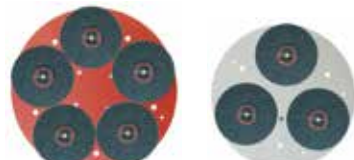

Ref.	Part No.	Description	Gr.	mm	Inch	Series					cm	Kg	Price			
						IPERTINA PLUS	IPERTINA	MAXITINA	SUPERTINA	MICROITINA				MEGATINA		
3	249 IPER	8024648016010	1	Disc with 5 silicon carbide abrasive flap discs	Gr. 16	490 mm	19 1/4"	•	•	-	-	-	-	54x54xh 10	7,6	135,00
3	249	8024648003157	1	Disc with 5 silicon carbide abrasive flap discs	Gr. 16	490 mm	19 1/4"	-	-	•	-	-	-	47x47xh 9	7,6	121,80
4	229	8024648003164	1	Disc with 3 silicon carbide abrasive flap discs	Gr. 16	420 mm	16 1/2"	-	-	-	•	-	-	47x47xh 9	5,5	99,00

3

4

BASE-PLATE (DISC HOLDER FOR ABRASIVE TOOLS)

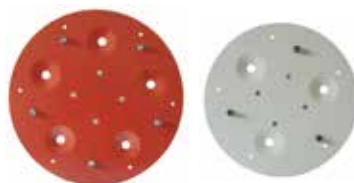

Ref.	Part No.	Description	mm	Inch	Series					cm	Kg	Price			
					IPERTINA PLUS	IPERTINA	MAXITINA	SUPERTINA	MICROITINA				MEGATINA		
5	250 P IPER	8024648016027	1	Disc holder for abrasive tools (nr.5)	490 mm	19 1/4"	•	•	-	-	-	-	54x54xh 10	6,5	86,00
5	250 P MOLE	8024648003089	1	Disc holder for abrasive tools (nr.5)	490 mm	19 1/4"	-	-	•	-	-	-	54x54xh 10	6,5	69,70
6	230 P MOLE	8024648003096	1	Disc holder for abrasive tools (nr.3)	420 mm	16 1/2"	-	-	-	•	-	-	54x54xh 10	4,9	63,50

5

6

ABRASIVE TOOLS



Ref.	Part No.	Description	mm	Inch	mm	Inch	n. tools per plate		cm	Kg	Price	
							490 mm	420 mm				
7	273 W 16	8024648003102	5	Wolfram carbide plate	16	125 mm	5"	5	3	25x15xh10	5	41,50
8	273 W 6	8024648003119	5	Wolfram carbide plate	6	125 mm	5"	5	3	25x15xh10	5	42,90
9	273	8024648003140	5	Silicon carbide cup wheel (14 MA fitting)	16	110 mm	4 3/8"	5	3	25x25xh10	3	8,40
10	274 18 G 16 C	8024648014139	5	Single face silicon carbide flap wheel	16	178 mm	7"	5	3	20x20xh5	0,75	3,70
10	274 18 G 24 C	8024648079596	5	Single face silicon carbide flap wheel	24	178 mm	7"	5	3	20x20xh5	0,75	3,70
10	274 18 G 36 C	8024648014146	5	Single face silicon carbide flap wheel	36	178 mm	7"	5	3	20x20xh5	0,75	3,70
11	158 G F 03 D	8024648017413	5	14 MA Ø60 metal flange for abrasive di	-	-	-	-	-	-	0,5	5,90

7

8

9

10

11

GROUTING BLADES



Ref.	Part No.	Description	mm	Inch	Series					cm	Kg	Price			
					IPERTINA PLUS	IPERTINA	MAXITINA	SUPERTINA	MICROITINA				MEGATINA		
12	212	8024648002914	1	Grouting paddle with 8 non-abrasive rubbers	500 mm	19 5/8"	•	•	•	-	-	-	54x54xh 10	5,9	164,00
12	167	8024648002921	1	Grouting paddle with 8 non-abrasive rubbers	420 mm	16 1/2"	-	-	-	•	-	-	47x47xh 9	4,7	151,00
	272 8	8024648002945	1	Replacement rubber grouting blades, set of 8	-	-	-	-	-	•	-	-	-	1,8	86,00

12

12

12

12

SMOOTHING STEEL DISC



Ref.	Part No.	Description	mm	Inch	Series					cm	Kg	Price			
					IPERTINA PLUS	IPERTINA	MAXITINA	SUPERTINA	MICROITINA				MEGATINA		
13	214	8024648002983	1	Steel disc	600 mm	23 5/8"	•	•	•	-	-	-	68x68xh 10	6,3	93,50
13	388	8024648002976	1	Steel disc	510 mm	20"	-	-	-	•	-	-	54x54xh 10	5,2	77,50

13

13

13

BERTA ADV - SPONGE MACHINE



7	399ADV	8024648004529	1	Berta ADV with "Havana" sponge roller	Single-phase	230 V 50/60 Hz	120	73x60xh55	37	1.330,00
7	399ADV GB	8024648009685	1	Berta ADV with "Havana" sponge roller	Single-phase	110 V 50 Hz	120	73x60xh55	37	1.350,00
7	399ADV USA	8024648009692	1	Berta ADV with "Havana" sponge roller	Single-phase	110 V 60 Hz	120	73x60xh55	37	1.350,00

TECHNICAL CHARACTERISTICS



ROSINA - SPONGE MACHINE



2	380DF	8024648003249	1	Rosina with "Havana" sponge roller	Single-phase	230 V 50/60 Hz	370	100x60xh 75	67	1.970,00
---	--------------	---------------	---	------------------------------------	--------------	----------------	-----	-------------	----	-----------------

TECHNICAL CHARACTERISTICS

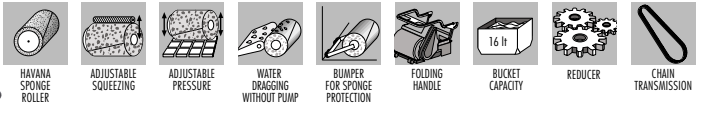

SPONGE ROLLERS



HAVANA



SWEEPEX



CELLULOSE

3	380RULLO	8024648004925	4	"Havana" sponge roller (for cement-based grout)				75x60xh40	10,6	51,00
4	380RULSWE	8024648003263	4	Sweepex sponge roller (for cement-based grout)				75x60xh40	11	60,00
5	380RULEPO	8024648003270	4	Cellulose sponge roller (for epoxy-based grout)				75x60xh40	12,2	106,50

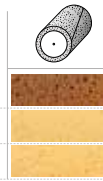

ANTIFOAMING LIQUIDS



6



7

6	380ANTISC400	8024648011800	1	Antifoaming liquid bottle				400 gr	20x20xh15	3	7,40
7	380ANTISC	8024648003256	1	Antifoaming liquid bottle				100 gr	27x10xh15	1,3	2,80





PEDALO'

1



7	356NSWEE	8024648007414	1	"Pedalo" equipped with: Sweepex pole sponge 13x42 cm Sweepex pole sponge 17x34 cm Sectional aluminum handle	40		70x55x40	13,6	183,00
7	356NSWET	8024648007407	1	"Pedalo" equipped with: Sweepex pole sponge with cuts 13x42 cm Sweepex pole sponge with cuts 17x34 cm Sectional aluminum handle	40		70x55x40	13,6	184,30



RAMBO

2



2	355NSWEE	8024648007421	1	"Rambo" equipped with: Sweepex pole sponge 13x42 cm Sweepex pole sponge 17x34 cm Sectional aluminum handle	40		65x50x32	10,3	136,00
2	355NSWET	8024648015372	1	"Rambo" equipped with: Sweepex pole sponge with cuts 13x42 cm Sweepex pole sponge with cuts 17x34 cm Sectional aluminum handle	40		65x50x32	10,3	137,30



PULIRAPID

3



3	216SWE	8024648006684	1	"Pulirapid" equipped with: Sweepex pole sponge 13x30 cm	20		60x33x33	5	88,00
3	216SWET	8024648015389	1	"Pulirapid" equipped with: Sweepex pole sponge with cuts 13x30 cm	20		60x33x33	5	89,00
	157PU01D	8024648011473	1	Plastic grating	-	-	-	0,3	3,90



EASY

4



4	244ADV	8024648074584	8	"Easy" 8 pieces in display box equipped with: Sweepex sponge float 13x30 cm and 5 residues - collecting bags	10		60x35x100	26	65,00
4	244ADV SWE4	8024648077400	4	"Easy" 4 pieces in display box equipped with: Sweepex sponge float 13x30 cm and 5 residues - collecting bags	10		60x35x60	13	67,50
	244SC01A	8024648075796	1	Residues - collecting bags (20 pcs package)	-	-	-	-	11,70



SMART

5



5	244	8024648074577	8	"Smart" 8 pieces in display box equipped with: Sweepex sponge float 13x30 cm	10		60x35x100	20,1	49,50
5	244 SWE4	8024648077394	4	"Smart" 4 pieces in display box equipped with: Sweepex sponge float 13x30 cm	10		60x35x60	10	51,50



SKIPPER

6



6	242C/F SWE8	8024648009876	8	"Skipper" 8 pieces in display box equipped with: Sweepex pole sponge 13x30 cm	13		60x35x100	22,4	57,00
7	242C/ SWE4	8024648009869	4	"Skipper" 4 pieces in display box equipped with: Sweepex pole sponge 13x30 cm	13		60x35x60	11,3	59,20
	157PU01D	8024648011473	1	Plastic grating	-	-	-	0,3	3,90
	201RV04D	8024648011510	2	Squeezing roller	-	-	-	0,2	3,20



SPONGE FLOATS 13X30Xh3 cm

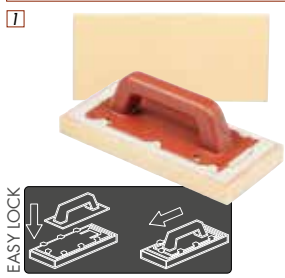

7											
		7	217	8024648001238	15	"Havana" sponge float Easy Lock	13x30xh3		58x30xh38	5	6,20
		7	217SWE	8024648007360	15	"Sweepex" sponge float Easy Lock	13x30xh3		58x30xh38	5	7,10
		7	217SWET	8024648007377	15	"Sweepex" sponge float with cuts Easy Lock	13x30xh3		58x30xh38	5	7,60
		7	217SWESCON	8024648017567	15	Carved "Sweepex" sponge float Easy Lock	13x30xh3		58x30xh38	5	8,00

QUICK CHANGE REPLACEMENT SPONGES 13X30Xh3 cm

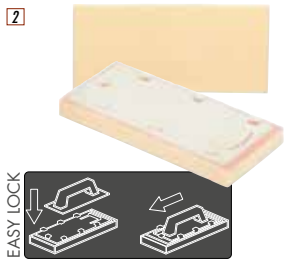

2											
		2	217RIC	8024648001139	30	"Havana" replacement sponge Easy Lock	13x30xh3		45x40xh30	5,4	3,10
		2	217RICSWE	8024648005311	30	"Sweepex" replacement sponge Easy Lock	13x30xh3		45x40xh30	5,4	3,90
		2	217RICSWG	8024648005328	30	"Sweepex" replacement sponge with cuts Easy Lock	13x30xh3		45x40xh30	5,4	4,50
		2	217RICSWESCO	8024648017598	30	Carved "Sweepex" replacement sponge Easy Lock	13x30xh3		45x40xh30	5,4	5,70
		2	217RICCEL	8024648014115	30	"Cellulose" replacement sponge for epoxy Easy Lock	13x30xh3		45x40xh30	6,8	9,60

SPONGE FLOATS 17X34Xh4 cm



3											
		3	336	8024648001221	10	"Havana" sponge float Easy Lock	17x34xh4		58x30xh38	4,6	7,85
		3	336SWE	8024648007353	10	"Sweepex" sponge float Easy Lock	17x34xh4		58x30xh38	4,6	9,25
		3	336SWET	8024648007438	10	"Sweepex" sponge float with cuts Easy Lock	17x34xh4		58x30xh38	4,6	9,60
		3	336SWESCO	8024648017574	10	Carved "Sweepex" sponge float Easy Lock	17x34xh4		58x30xh38	4,6	10,60

QUICK CHANGE REPLACEMENT SPONGES 17X34Xh4 cm

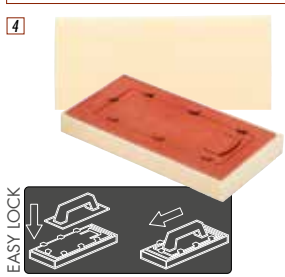

4											
		4	336RIC	8024648001047	15	"Havana" replacement sponge Easy Lock	17x34xh4		45x40xh30	4	4,45
		4	336RICSWE	8024648005335	15	"Sweepex" replacement sponge Easy Lock	17x34xh4		45x40xh30	4	5,80
		4	336RICSWG	8024648005342	15	"Sweepex" replacement sponge with cuts Easy Lock	17x34xh4		45x40xh30	4	6,50
		4	336RICSWESCO	8024648017581	15	Carved "Sweepex" replacement sponge Easy Lock	17x34xh4		45x40xh30	4	8,00
		4	336RICCEL	8024648014122	15	"Cellulose" replacement sponge for epoxy Easy Lock	17x34xh4		45x40xh30	5,4	16,00

QUICK CHANGE HANDLE



5											
		5	306IR20DN	8024648087911	25	Quick change handle for Art.217/336 Easy Lock	24x10	-	45x40xh30	4	2,35

DISPOSABLE/ONE-PIECE SPONGE FLOATS

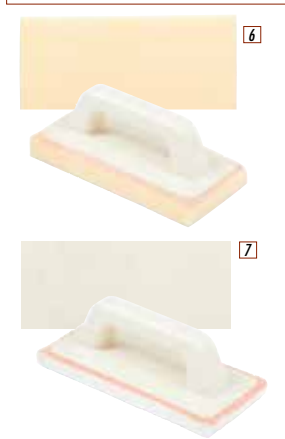

6											
		6	395U/G	8024648006318	24	Disposable "Sweepex" sponge float	12x26xh3		58x30xh38	5,3	4,30
		7	395U/GCEL	8024648080653	24	Disposable "Cellulose" sponge float (for epoxy grout)	12x26xh3		58x30xh38	5,3	8,60



SPONGE FLOATS 13X42Xh3 cm

1



7	355FSMOH	8024648001191	5	"Havana" sponge float without handle	13x42x3		58x30xh25	7,5	18,70
7	355FSSWOH	8024648005427	5	"Sweepex" sponge float without handle	13x42x3		58x30xh25	7,5	19,60
7	355FSSWOHT	8024648009807	5	"Sweepex" sponge float with cuts without handle	13x42x3		58x30xh25	7,5	20,10
7	355FSSWSCO	8024648017864	5	Carved "Sweepex" sponge float without handle	13x42x3		58x30xh25	7,5	20,30

REPLACEMENT SPONGES 13X42Xh3 cm

2

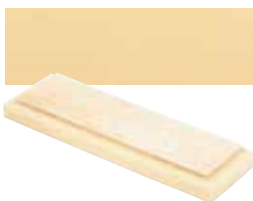

2	355RIC	8024648001061	20	"Havana" replacement sponge	13x42x3		45x40xh30	5,8	3,80
2	355RICSWE	8024648007384	20	"Sweepex" replacement sponge	13x42x3		45x40xh30	5,8	4,75
2	355RICSWET	8024648007391	20	"Sweepex" replacement sponge with cuts	13x42x3		45x40xh30	5,8	5,40
2	355RICSWESCO	8024648017871	20	Carved "Sweepex" replacement sponge	13x42x3		45x40xh30	5,8	6,60
2	355RICCEL	8024648014108	20	"Cellulose" replacement sponge for epoxy	13x42x3		45x40xh30	8,6	14,90

REPLACEMENT SPONGES 13X29Xh4 cm

3



3	331RIC	8024648001030	20	"Havana" replacement sponge	13x29x4		45x40xh30	4,5	3,20
---	---------------	---------------	----	-----------------------------	---------	--	-----------	-----	-------------

ANODIZED ALUMINUM HANDLES



4	197	8024648000637	12	Without hole	133		140x20xh10	5,5	8,30
5	197SC	8024648014511	10	Sectional with hole	133		71x23xh15	6,7	11,60

SPONGES

6



6	291SWENYL	8024648011060	50	"Sweepex" sponge	• 16x12xh7		61x24xh36	2,6	2,30
7	291MAXIT	8024648001252	50	"Havana" sponge	• 19x12xh7		61x24xh36	2,7	1,00
8	291	8024648001245	72	"Havana" sponge	• 14x11xh6		61x24xh36	2,2	0,70
9	291SWERIG	8024648011091	30	"Sweepex" sponge + hard abrasive sponge	• 16x9xh7		39x35xh31	1,3	3,10
10	291CELRIG	8024648011107	30	Spugna "Cellulosa" + hard abrasive sponge for epoxy	• 16x9xh7		39x35xh31	2,5	4,95
11	291EPOXI	8024648001269	30	Hard abrasive sponge	• 16x9xh7		39x35xh31	1,6	2,40
12	291OVALE	8024648006301	30	Spugna "Cellulosa" for epoxy	• 19x12xh4		39x35xh31	3,1	5,55

7



8



9



10



11



12





GROUTSAW WITH INTERCHANGEABLE BLADES



7	275	8024648007896	10	"Abrafughe" grout saw with 2 blades	27x15xh10	0,5	6,95
	275RIC	8024648007902	10	Spare blade	-	-	2,60

FLOAT WITH ABRASIVE FELT PADS

2



2	226	8024648000583	12	"Finish" with 2 felt pads (black and white) 120x250xh20 mm	39x35xh31	4	8,50
3	306IV01D	8024648005304	12	Handle with velcro	39x35xh31	2,6	4,65

REPLACEMENT FELT PADS

4



4	227M	8024648059093	10	Brown felt pad 120x250xh 20 mm (highest abrasiveness)	25x25xh11	0,8	2,07
5	227N	8024648000590	10	Black felt pad 120x250xh 20 mm (high abrasiveness)	25x25xh11	0,8	2,07
6	227V	8024648071385	10	Green felt pad 120x250xh 20 mm (medium abrasiveness)	25x25xh11	0,8	2,07
7	227B	8024648000606	10	White felt pad 120x250xh 20 mm (low abrasiveness)	25x25xh11	0,3	2,07

BROOMS

8



8	348A	8024648000613	12	"Battista" soft bristles broom (without handle)	39x35xh31	5,2	6,00
9	348B	8024648000620	12	"Battista" stiff bristles broom (without handle)	39x35xh31	5,2	6,00

ANODIZED ALUMINUM POLE

11



11	197	8024648000637	12	Without hole	133	140x20xh10	5,5	8,30
10	197SC	8024648014511	10	Sectional with hole	133	71x23xh15	6,7	11,60
11	197180CM	8024648000644	12	With hole	180	180x20xh10	7,2	11,40



NOTCHED TROWELS 28x13 cm RUBBER HANDLE

					Notch size	Notch type					
	183HFV10	8024648016737	6	Rubber handle notched trowel	10 mm		28x13	32x22xh15	4	11,00	
	183HFV8	8024648016744	6	Rubber handle notched trowel	8 mm		28x13	32x22xh15	4	11,00	
	183HFV6	8024648016751	6	Rubber handle notched trowel	6 mm		28x13	32x22xh15	4	11,00	

NOTCHED TROWELS 36x13 cm RUBBER HANDLE



					Notch size	Notch type				
	184HFV10G	8050532005006	6	Rubber handle notched trowel	10 mm		36x13	38x30xh12	3	13,80

NOTCHED TROWELS 36x13 cm RUBBER HANDLE

					Notch size	Notch type				
	184Q12G	8024648003911	6	Rubber handle notched trowel	12x12 mm		36x13	38x30xh12	3	10,50
	184Q10G	8024648003904	6	Rubber handle notched trowel	10x10 mm		36x13	38x30xh12	3	10,50
	184Q08G	8024648086785	6	Rubber handle notched trowel	8x8		36x13	38x30xh12	3	10,50
	184Q06G	8050532001374	6	Rubber handle notched trowel	6x6		36x13	38x30xh12	3	10,50
	184Q03G	8024648003874	6	Rubber handle notched trowel	3x3 mm		36x13	38x30xh12	3	10,50
	184V06G	8024648086716	6	Rubber handle notched trowel	V 8 mm		36x13	38x30xh12	3	10,50
	184V09G	8024648086723	6	Rubber handle notched trowel	V 11 mm		36x13	38x30xh12	3	10,50
	184T15G	8024648004208	6	Rubber handle notched trowel	15 mm		36x13	38x30xh12	3	10,50

NOTCHED TROWELS 28x12 cm RUBBER HANDLE

					Notch size	Notch type				
	183Q12G	8024648010483	16	Rubber handle notched trowel	12x12 mm		28x12	63x30xh12	5,8	9,00
	183Q10G	8024648010490	16	Rubber handle notched trowel	10x10 mm		28x12	63x30xh12	5,8	9,00
	183Q8G	8024648010506	16	Rubber handle notched trowel	8x8 mm		28x12	63x30xh12	5,8	9,00
	183Q6G	8024648010520	16	Rubber handle notched trowel	6x6 mm		28x12	63x30xh12	5,8	9,00
	183Q3G	8024648078490	6	Rubber handle notched trowel	3x3 mm		28x12	29x27xh12	2,2	9,00
	183V9G	8024648010551	16	Rubber handle notched trowel	V 11 mm		28x12	29x27xh12	5,8	9,00
	183V6G	8024648007759	16	Rubber handle notched trowel	V 9 mm		28x12	63x30xh12	5,8	9,00
	183T15G	8024648010537	6	Rubber handle notched trowel	15 mm		28x12	29x27xh12	2,2	9,00
	183T9G	8024648010568	6	Rubber handle notched trowel	9 mm		28x12	29x27xh12	2,2	9,00

NOTCHED TROWELS 28x12 cm WOOD HANDLE

					Notch size	Notch type				
	183 12X12	8024648000194	16	Wood handle notched trowel	12x12 mm		28x12	63x30xh12	5,8	7,70
	183	8024648000187	16	Wood handle notched trowel	10x10 mm		28x12	63x30xh12	5,8	7,70
	183 8X8	8024648000200	16	Wood handle notched trowel	8x8 mm		28x12	63x30xh12	5,8	7,70
	183 6X6	8024648000217	16	Wood handle notched trowel	6x6 mm		28x12	63x30xh12	5,8	7,70
	183 3X3	8024648010407	6	Wood handle notched trowel	3x3 mm		28x12	29x27xh12	2,2	7,70
	183 V9	8024648000231	16	Wood handle notched trowel	V 11 mm		28x12	63x30xh12	5,8	7,70
	183 V6	8024648000224	16	Wood handle notched trowel	V 9 mm		28x12	63x30xh12	5,8	7,70
	183 V3	8024648010544	6	Wood handle notched trowel	V 3 mm		28x12	29x27xh12	2,2	7,70
	183 T15	8024648000248	6	Wood handle notched trowel	15 mm		28x12	29x27xh12	2,2	7,70
	183 T9	8024648000255	6	Wood handle notched trowel	9 mm		28x12	29x27xh12	2,2	7,70
	183 S	8024648010513	16	Wood handle notched trowel.Left	10x10 mm		28x12	63x30xh12	5,8	7,70
	183 8X8S	8024648007742	16	Wood handle notched trowel.Left	8x8 mm		28x12	63x30xh12	5,8	7,70

**NOTCHED TROWELS 48x13 cm
WOOD HANDLE**

1



2



3



					Notch size	Notch type					
7	182 12x12	8024648006660	12	Wood handle notched trowel	12x12 mm		48x13	49x34xh17	7,6	12,60	
7	182	8024648000118	12	Wood handle notched trowel	10x10 mm		48x13	49x34xh17	7,6	12,60	
7	182 8x8	8024648000125	12	Wood handle notched trowel	8x8 mm		48x13	49x34xh17	7,6	12,60	
7	182 6x6	8024648000132	12	Wood handle notched trowel	6x6 mm		48x13	49x34xh17	7,6	12,60	
2	182 V9	8024648000156	12	Wood handle notched trowel	V 11 mm		48x13	49x34xh17	7,6	12,60	
2	182 V6	8024648000149	12	Wood handle notched trowel	V 9 mm		48x13	49x34xh17	7,6	12,60	
3	182 T15	8024648000163	4	Wood handle notched trowel	15 mm		48x13	50x25xh10	2,7	12,60	
3	182 T9	8024648006677	4	Wood handle notched trowel	9 mm		48x13	50x25xh10	2,7	12,60	

**"COLOMBO"
THIN-SET / ADHESIVE SPREADER**

4

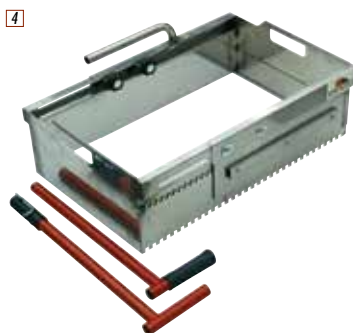

						Notch type				
4	397/66	8024648015433	1	"Colombo" for tiles up to 66 cm			50x50xh25	15		285,00
				Equipped with: two dual notch blades 8x8/10x10 mm						
				two dual notch blades 6x6/12x12 mm						

DUAL NOTCH BLADES

5

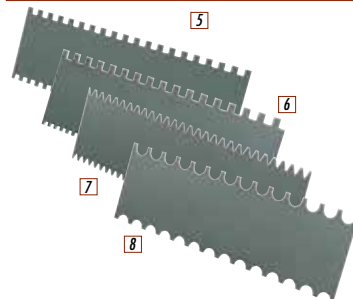

						Notch type				
5	397L36Q8/10	8024648015495	1	Dual notch blades for Colombo	8x8/10x10mm		40x15xh5	3		20,40
6	397L36Q6/12	8024648015501	1	Dual notch blades for Colombo	6x6/12x12mm		40x15xh5	3		20,40
7	397L36V8/11	8024648015518	1	Dual notch blades for Colombo	V8/11mm		40x15xh5	3		20,40
8	397L36T9/15	8024648015525	1	Dual notch blades for Colombo	9/15mm		40x15xh5	3		20,40

NOTCHED TROWEL

9



						Notch type				
9	148	8024648000279	12	Notched trowel with plastic handle	28	V 3 mm		33x33xh10	3,4	4,80
9	149	8024648000286	12	Notched trowel with plastic handle	28	V 11 mm		33x33xh10	3,4	4,80
10	148Q10	8024648014481	12	Notched trowel with aluminium handle	20	10x10 mm		22x15xh13	1,3	2,10
10	148Q8	8024648014498	12	Notched trowel with aluminium handle	20	8x8 mm		22x15xh13	1,3	2,10
10	148Q6	8024648014504	12	Notched trowel with aluminium handle	20	6x6 mm		22x15xh13	1,3	2,10
11	148N5	8024648007810	12	Notched trowel with aluminium handle	20	V 5 mm		22x15xh13	1,3	2,10
11	148N3	8024648007797	12	Notched trowel with aluminium handle	20	V 3,5 mm		22x15xh13	1,3	2,10

NOTCHED TROWEL FOR SKIRTING

12



						Notch type				
12	40910x10	8024648004932	12	"Zoccolina" notched trowel	13	10x10 mm		27x15xh10	1,9	4,30

FIDO



1	174	8024648086648	2	"Fido" ergonomic support	27x15xh10	1,20	19,90
---	------------	---------------	---	--------------------------	-----------	------	--------------

"ISOLA" PLATFORM



2	390	802464800064	5	"Isola" to walk over the floor without moving the tiles (for "+" joints only)	33x33xh10	7,7	15,70
3	390BU	8024648010667	5	"Penisola" to walk over the floor without moving tiles when laying with adhesive (for "T" joints only)	33x33xh10	4	18,00

THINSET SHOES FOR WALKING ON THINSET/ADHESIVE



4	137HUSKY	8024648000057	4	"Husky" toothed shoes (per pair)	34x27xh30	7	26,60
---	-----------------	---------------	---	----------------------------------	-----------	---	--------------

MIXING PADDLES FOR MIXING DRILLS



5	178389L	8024648079541	1	Mixing paddle 2 spirals (14MA screw) 14MA	∅	160 mm - 6 9/32"	60x12xh16 2,5 27,00
5	178389F	8024648017888	1	Mixing paddle 2 spirals (14MA screw) 14MA		140 mm - 5 3/4"	60x12xh16 1,7 26,00
5	178 389G	8024648017895	1	Mixing paddle 2 spirals (14MA screw) 14MA		120 mm - 4 3/4"	60x12xh16 1,7 22,00
6	178 389E	8024648009814	1	4-poles mixing paddle (14MA screw)		140 mm - 5 3/4"	60x12xh16 1,6 16,00
7	178 S	8024648000392	10	Dual spiral mixing paddle		90 mm - 3 1/2"	60x34xh16 5,3 9,00
8	178	8024648000385	16	4 hexagonal poles mixing paddle		120 mm - 4 3/4"	60x34xh16 7 5,10
9	178D60	8024648056887	12	Mixing paddle 2 spirals hexagonal poles		60 mm - 2 3/8"	44x15xh14 2,8 3,10
10	178D80	8024648058195	12	Mixing paddle 2 spirals hexagonal poles		80 mm - 3 1/8"	44x19xh18 3,1 3,55

BUCKETS



11	289CMAN	8024648000996	1	Bucket with steel handle		45 lt - 12 gal	- 13,5 26,20
12	289IPER	8024648000989	1	Bucket with handles		45 lt - 12 gal	- 23 13,70
13	289CICO	8024648007605	1	Bucket with steel handle		27 lt - 7 gal	- 9 17,50
14	289LT27	8024648006288	1	Bucket with handles		27 lt - 7 gal	- 15 13,00



SHEAT-PRESSER ROLLERS



15	232 RAI	8024648073587	4	Sheat-presser roller with telescopic handle	122x40xh 27	18	105,00
16	232WALL R	8024648097415	1	Sheat-presser roller for wall	20x21xh 5	0,8	29,50





RECTANGULAR FINISHING TROWELS (STEEL)



Ref.	Part No.	Description	cm	Kg	€			
7	182L	8024648000170	12	Smooth steel trowel with wooden handle	48x13 cm	49x34xh17	7,6	12,10
4	184LG	80246480003867	6	Smooth steel trowel with rubber handle	36x13 cm	38x30xh12	3	10,30
2	183L	8024648000262	16	Smooth steel trowel with wooden handle	28x12 cm	63x30xh12	5,8	7,20
3	183LG	8024648007766	16	Smooth steel trowel with rubber handle	28x12 cm	63x30xh12	5,8	8,40

TRAPEZOIDAL FINISHING TROWELS (STAINLESS STEEL)



Ref.	Part No.	Description	cm	Kg	€			
5	142INX28	8024648007964	12	Smooth stainless steel trowel with wooden handle	28x12 cm	55x30xh11	4,3	13,30
6	142INX24	8024648007957	12	Smooth stainless steel trowel with wooden handle	24x10 cm	55x30xh11	3,7	13,20
7	142INX20	8024648007940	20	Smooth stainless steel trowel with wooden handle	20x8 cm	55x30xh11	5,2	12,40

BRICKLAYING TROWELS



Ref.	Part No.	Description	cm	Kg	€			
8	341PQL160	8024648065759	6	Round point. With anti-slip rubber handle and finger guard	160 mm	40x15xh16	1,75	7,40
8	341PQL180	8024648066077	6	Round point. With anti-slip rubber handle and finger guard	180mm	40x15xh16	1,80	7,40
8	341PQL190	8024648066084	6	Round point. With anti-slip rubber handle and finger guard	190mm	40x15xh16	1,85	7,50
8	341PQL200	8024648066091	6	Round point. With anti-slip rubber handle and finger guard	200mm	42x16xh17	1,90	7,60
9	341PTN160	8024648065766	6	Round point. With anti-slip rubber handle and finger guard	160 mm	40x15xh16	1,70	7,40
9	341PTN180	8024648066152	6	Round point. With anti-slip rubber handle and finger guard	180mm	40x15xh16	1,75	7,40
9	341PTN190	8024648066169	6	Round point. With anti-slip rubber handle and finger guard	190mm	40x15xh16	1,80	7,50
9	341PTN200	8024648066176	6	Round point. With anti-slip rubber handle and finger guard	200mm	42x16xh17	1,85	7,60

SMALL BRICKLAYING TROWELS



Ref.	Part No.	Description	cm	Kg	€			
10	342PQN140	8024648066268	6	Round point. With anti-slip rubber handle and finger guard	140mm	31x11xh14	1	5,90
11	342PTN140	8024648066275	6	Round point. With anti-slip rubber handle and finger guard	140mm	31x11xh14	0,80	5,90
12	342PAN140	8024648066237	6	Pointed trowel. With anti-slip rubber handle and finger guard	140mm	31x11xh14	0,70	5,90
13	342PLG140	8024648066251	6	Cat tongue shape. With anti-slip rubber handle and finger guard	140mm	31x11xh14	0,70	5,90
14	342PFU140	8024648066244	6	Olive leaf shape. With anti-slip rubber handle and finger guard	140mm	31x11xh14	0,65	5,90

PROFESSIONAL SCRAPERS



Ref.	Part No.	Description	cm	Kg	€			
15	343SSL020	8024648066282	12	Handle made in beech selected wood	20mm	27x10xh 14	0,70	1,73
15	343SSL030	8024648066299	12	Handle made in beech selected wood	30mm	27x10xh 14	0,75	1,86
15	343SSL040	8024648066305	12	Handle made in beech selected wood	40mm	27x10xh 14	0,80	1,90
15	343SSL050	8024648066312	12	Handle made in beech selected wood	50mm	27x10xh 14	0,90	2,05
15	343SSL060	8024648066329	12	Handle made in beech selected wood	60mm	27x10xh 14	0,95	2,12
15	343SSL070	8024648066336	12	Handle made in beech selected wood	70mm	27x10xh 14	1	2,17
15	343SSL080	8024648066343	12	Handle made in beech selected wood	80mm	27x10xh 14	1,05	2,50
15	343SSL090	8024648066350	12	Handle made in beech selected wood	90mm	27x10xh 14	1,10	2,60
15	343SSL100	8024648066367	12	Handle made in beech selected wood	100mm	27x10xh 14	1,20	2,80

LEVEL PLUMB JOINTED SQUARE



1	186	8024648000859	1	Level plumb square. Length 100 cm	102x12xh6	1,4	69,90
	187	8024648000866	1	Level plumb square. Length 50 cm	52x12xh6	0,8	58,90

ALL ANGLE GUIDE



2	252 50	8024648000897	1	"Diagonal 50" For tiles up to 50x50 cm	75x15xh13	6,3	49,50
----------	---------------	---------------	---	--	-----------	-----	--------------

WALL LEVELING GUIDE



3	131 1	8024648000958	3	KRICK-KROCK leveling guide for first row of tiles - max h 30 cm	33x33xh10	2,5	23,40
----------	--------------	---------------	---	---	-----------	-----	--------------

SPEED-STAIRS SETTER



4	171	8024648000941	8	Coppia "Speed" for steps setting (pair)	58x30xh25	13,1	33,80
----------	------------	---------------	---	---	-----------	------	--------------



WAFFLED SHOES



1	137	8024648000019	10	Waffled, for tiles, with elastic strap	per pair	50x43xh43	13,2	12,00
2	137MOLLA	8024648000026	10	Waffled, for tiles, with spring*	per pair	50x43xh43	14,2	12,00



SMOOTH SHOES



3	137B	8024648000033	12	Smooth, for mortar base, with elastic strap	per pair	50x43xh43	14,4	11,70
4	137BMOLLA	8024648000040	12	Smooth, for mortar base, with spring	per pair	50x43xh43	15,6	11,70



TOOTHED SHOES



5	137HUSKY	8024648000057	4	Toothed shoe "Husky" for walking on adhesive	per pair	34x27xh30	7	26,60
----------	-----------------	---------------	---	--	----------	-----------	---	--------------

SPARE PARTS FOR SHOES

196	8024648004888	10	Elastic strap for shoes	—	0,2	0,95
137FE01D	8024608011918	20	Elastic strap holder	—	—	0,13
314TR02D	8024648005236	10	Spring with clip	—	0,4	1,55
137PU01D	8024648015983	2	Toe-guard for "Husky"	—	0,2	0,80

KNEE GUARDS "RELAX GEL"



6	138RELAX	8024648062680	12	RELAX-GEL Knee pad	per pair	49x40xh34	9	21,00
----------	-----------------	---------------	----	--------------------	----------	-----------	---	--------------

KNEE GUARDS



7	138SOFF	8024648000088	12	Knee pads with ribs	per pair	• 39x35xh31	7,6	22,60
8	138	8024648000071	16	Knee pads	per pair	• 39x35xh31	6	13,90
9	196GCA	8024648064141	10	Fabric band with hooks for knee pads		—	0,2	0,50



"MORBIDONE" FOAM BOARD



10	330	8024648000095	5	"Morbidone" foam knee board		58x30xh25	4,9	21,70
-----------	------------	---------------	---	-----------------------------	--	-----------	-----	--------------

ROLLING SEATS



11	383COMBI	8024648015396	1	"Nelson" seat with kneepad. Adjustable height		60x40xh25	11	199,00
12	383TRI	8024648006332	1	"Napoleone" seat. Adjustable height		38x30xh30	4,7	91,70

TROLLEYS AND WORK BENCHES



1	384TRI	8024648006325	1	"Elio" bucket holder. Tile dolly	40x40xh15	3,4	53,00
2	394	8024648003645	1	"Pugiol" work bench . Size 45x77xh 74 cm	100x50xh12	10	140,00
3	394MA RAI	8050532000995	1	"BM180 ^{MM} " - modular bench with folding legs	190x21x h 10 + 117x20x h 20 cm		468,00
4	394MA PLUS	8050532007062	1	"BM180 ^{PLUS} " modular working bench w/ variable width (100-150 cm) with folding legs	190x21x h 10 + 117x20x h 20 cm	39,6	615,00
	394PT01D3A	8050532007321	1	Anodized aluminum profile for BM180 ^{PLUS}	185xØ 103,5		60,00



PATENT PENDING

SUCTION CUPS



5	185	8024648000354	10	"Medusa" single suction cup Ø 115 mm (4 1/2")	35x35xh14	3,8	9,45
6	185BI	8024648000361	5	Double suction cup Ø 115 mm - 4 1/2" (stain-free-rubber)	35x35xh14	4,8	32,90
7	185TRI	8024648000378	3	Triple suction cup Ø 115 mm - 4 1/2" (stain-free-rubber)	35x35xh14	4,2	39,70
8	185V150CS	8024648086945	1	Vacuum suction cup Ø 150 mm (6") with hard case (stain-free-rubber)	39x39xh15	1,8	125,00
9	185V150VCS	8024648095862	1	Vacuum suction cup Ø 150 mm (6") with vacuum gauge with hard case (stain-free-rubber)	39x39xh15	1,9	142,00

SPARE PARTS FOR SUCTION CUPS

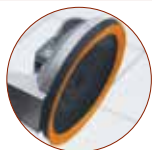

10	140FU03D	8024608011932	1	H 2 mm-3/32" self-stick washer, for rough surfaces		0,1	0,80
----	-----------------	---------------	---	--	--	-----	-------------

SLAB LIFTER

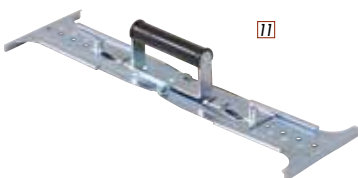

11	144	8024648000347	10	Extensible lifter for 30/35/40/45/50 cm tiles/slabs	40x40xh15	11,4	20,90
12	144CM50-65	8024648084871	2	Single handle extending tiles/slabs lifter - extension from 50 up to 65 cm (19 11/16" - 25 5/8")	71x23xh12	4,3	65,80
13	144CM50-120	8024648084750	2	Double handle extending tiles/slabs lifter - extension from 50 up to 120 cm (19 11/16" - 47 1/4")	117x20xh20	10,2	160,00

ANTI-BOUNCE WHITE RUBBER MALLETS



14	1761KGBC	8024648098122	8	gr. 1000 (2.2 lbs) white rubber mallet	40x32xh12	10,5	15,50
15	176500BC	8024648098139	12	gr. 500 (1.1 lbs) white rubber mallet	40x32xh12	9,5	11,90

ANTI-BOUNCE HAND TILE BEATER



16	142	8024648000910	6	Plastic tile beater 17x37 cm (6 1/2" x 14 1/2")	40x40xh15	9,4	23,90
17	142G	8024648078582	6	Rubber tile beater 145x350 mm	40x40xh15	9,4	30,00



ANODIZED ALUMINUM POLES



Ref.	Part No.	Description	cm					
1	197CF	8024648000316	12	With hole	133	140x20xh10	5,5	8,80
2	197SC	8024648014511	10	Sectional with hole	133	71x23xh15	6,7	11,60
7	197180CM	8024648000644	12	With hole	180	180x20xh10	7,2	11,40

SLIDES FOR SCREED



3	145SLITTA	8024648004635	1	Kit 4 pcs slides 5/10mm LL 1500 mm for screed		31x31xh5	2,4	21,00
---	-----------	---------------	---	---	--	----------	-----	--------------

HANDLES FOR STRAIGHT EDGE/LEVELS



4	421	8024648007124	2	"Kessler" for straight levels h min.50mm, max thickness 35 mm pair		18x28xh10	2	33,90
---	-----	---------------	---	--	--	-----------	---	--------------

MORTAR SPREADER



5	141PASQ	8024648000972	12	Steel mortar spreader (without pole)		58x30xh25	10,3	10,90
---	---------	---------------	----	--------------------------------------	--	-----------	------	--------------

PLASTER RASP

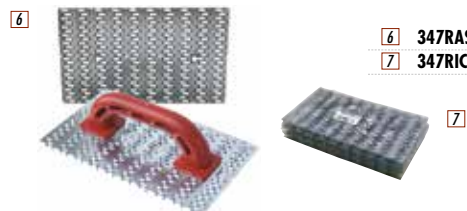

6	347RAS480	8024648015402	9	"Fakiro". Plaster rasp 250x145 mm		58x38xh30	4	6,35
7	347RIC480U	80246480059307	24	Replacement blades 250x145 mm		30x25xh15	7,2	3,80

SCRAPERS WITH STEEL BLADE



8	347 10	8024648000699	10	"Ginetta" stell blade scraper 10 cm		33x33xh10	3	10,60
9	347 15	8024648000705	10	"Ginetta" stell blade scraper 15 cm		33x33xh10	3,6	11,45
10	347 20	8024648000712	10	"Ginetta" stell blade scraper 20 cm		33x33xh10	4,2	12,45
11	347 25	8024648000729	8	"Ginetta" stell blade scraper 25 cm		33x33xh10	3,9	12,95

WOLFRAM CARBIDE DISCS FOR GRINDER

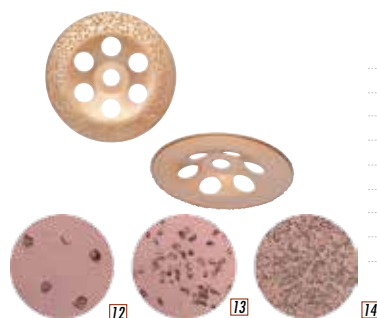

Ref.	Part No.	Description		mm					
12	273D115 W14	8024648074751	3	Wolfram carbide disc	115mm	4 1/2"	14	•	25,80
13	273D115 W24	8024648074768	3	Wolfram carbide disc	115mm	4 1/2"	24	•	25,80
14	273D115 W36	8024648074775	3	Wolfram carbide disc	115mm	4 1/2"	36	•	25,80
12	273D125 W14	8024648074782	3	Wolfram carbide disc	125mm	5"	14	•	31,55
13	273D125 W24	8024648074799	3	Wolfram carbide disc	125mm	5"	24	•	31,55
14	273D125 W36	8024648074805	3	Wolfram carbide disc	125mm	5"	36	•	31,55
12	273D180 W14	8024648074812	2	Wolfram carbide disc	180mm	7"	14	•	44,50
13	273D180 W24	8024648074829	2	Wolfram carbide disc	180mm	7"	24	•	44,50
14	273D180 W36	8024648074836	2	Wolfram carbide disc	180mm	7"	36	•	44,50

R.L.S. KIT



1	180KIT100	8024648067951	4	R.L.S. Kit Floor kit - consisting of: 1 pliers for floor covering; 100 wedges; 100 clips 1,5mm (1/16") for tile of thickness from 3 to 12mm (1/8" - 1/2")	51x51xh36	8,6	' - Z\$
	180KIT100RIV	8024648065209	4	R.L.S. Wall kit - consisting of: 1 pliers for wall covering; 100 wedges; 100 clips 1,5mm (1/16") for tile of thickness from 3 to 12mm (1/8" - 1/2")	51x51xh36	8,6	' - Z\$
2	180KIT3D	8024648086624	4	Kit R.L.S. "3D" consisting of; 1 plier for floor covering; 75 wedges; 75 clips "3D" for tile of thickness from 3 to 12mm (1/8" - 1/2")	49x39xh25	6,5	' + Z\$



R.L.S. WEDGES



4	180CUNE0100	8024648067944	12	R.L.S. wedge - 100 pieces bag	60x40xh31	10	12,70
4	180CUNE0250	8024648011947	6	R.L.S. wedge - 250 pieces bag	60x40xh31	11,7	29,90
4	180CUNE0500	8024648011954	3	R.L.S. wedge - 500 pieces bag	60x40xh31	11,7	56,90
3	180CU500SE	8024648072603	2	R.L.S. wedge - 500 pieces plastic bucket	62x42xh36	10,8	60,70
4	180CUNE01000	8024648069818	1	R.L.S. wedge - 1000 pieces carton box	30x40xh43	8,2	109,30



R.L.S. TRACTION ADJUSTABLE PLIERS

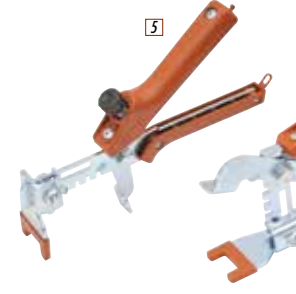

5	231 N	8024648072627	4	Adjustable pliers for floor covering	33x33xh10	2,6	26,90
6	231 NRIV	8024648072634	4	Adjustable pliers for wall covering	33x33xh10	2,5	26,90



R.L.S. "3D" CLIPS 3-12 mm JOINT 1,5 mm



				Pieces per Bag								
7	180B01MM3D0100	8024648083753	20	3D clips for tiles thick. from 3 to 12 mm (1/8"-1/2")	100	1,5 mm - 1/16"	•	•	•	30x40xh32	8	8,90
7	180B01MM3D0250	8024648083760	8	3D clips for tiles thick. from 3 to 12 mm (1/8"-1/2")	250	1,5 mm - 1/16"	•	•	•	30x40xh32	8	21,25
7	180B01MM3D0500	8024648083777	4	3D clips for tiles thick. from 3 to 12 mm (1/8"-1/2")	500	1,5 mm - 1/16"	•	•	•	30x40xh32	8	40,30
7	180B01MM3D3000	8024648083937	1	3D clips for tiles thick. from 3 to 12 mm (1/8"-1/2")	3000	1,5 mm - 1/16"	•	•	•	30x40xh42	10	206,00

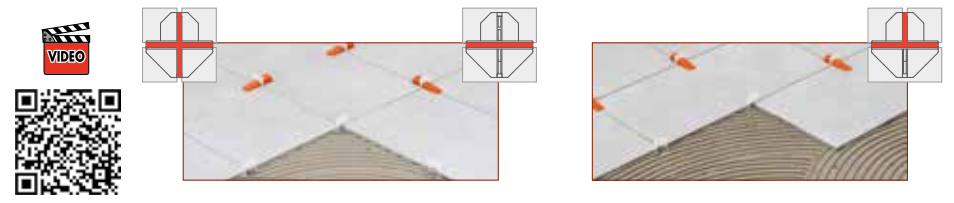

"R.L.S. "3D" CLIPS 3-12 mm JOINT 3 mm



				Pieces per Bag								
8	180B03MM3D0100	8024648094650	20	3D clips for tiles thick. from 3 to 12 mm (1/8"-1/2")	100	3 mm - 1/8"	•	•	•	30x40xh32	8,2	8,90
8	180B03MM3D0250	8024648094667	8	3D clips for tiles thick. from 3 to 12 mm (1/8"-1/2")	250	3 mm - 1/8"	•	•	•	30x40xh32	8,2	21,25
8	180B03MM3D0500	8024648094674	4	3D clips for tiles thick. from 3 to 12 mm (1/8"-1/2")	500	3 mm - 1/8"	•	•	•	30x40xh32	8,2	40,30
8	180B03MM3D3000	8024648094681	1	3D clips for tiles thick. from 3 to 12 mm (1/8"-1/2")	3000	3 mm - 1/8"	•	•	•	30x40xh42	10,1	206,00

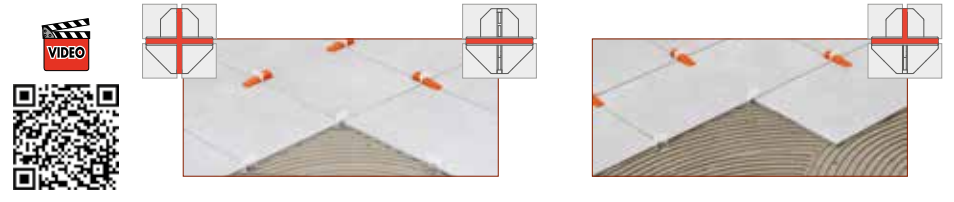



**R.L.S. "1 mm" CLIPS 3-12 mm
JOINT 1 mm**

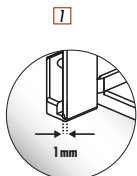

7	180BS0001C0100	8024648085337	24	"1mm" clips for tiles thick. from 3 to 12 mm (1/8"-1/2")	100	1 mm - 1/32"	•	-	-	40x30xh33	8,8	8,90
7	180BS0001C0250	8024648085344	10	"1mm" clips for tiles thick. from 3 to 12 mm (1/8"-1/2")	250	1 mm - 1/32"	•	-	-	40x30xh33	8,8	21,25
7	180BS0001C0500	8024648085351	5	"1mm" clips for tiles thick. from 3 to 12 mm (1/8"-1/2")	500	1 mm - 1/32"	•	-	-	40x30xh33	8,8	40,30
7	180BS0001C3000	8024648085368	1	"1mm" clips for tiles thick. from 3 to 12 mm (1/8"-1/2")	3000	1 mm - 1/32"	•	-	-	30x40xh43	10,2	206,00



Pieces per Bag	Diagram 1	Diagram 2	Diagram 3	Diagram 4	Dimensions	Weight	Price
100					40x30xh33	8,8	8,90
250					40x30xh33	8,8	21,25
500					40x30xh33	8,8	40,30
3000					30x40xh43	10,2	206,00

**R.L.S. CLIPS 3-12 mm
JOINT 1,5 mm**

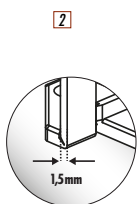

2	180BASE100	8024648067241	20	Clips for tiles thickness from 3 to 12 mm (1/8"-1/2")	100	1,5 mm - 1/16"	•	-	-	60x40xh31	9	8,90
2	180BASE250	8024648067937	8	Clips for tiles thickness from 3 to 12 mm (1/8"-1/2")	250	1,5 mm - 1/16"	•	-	-	60x40xh31	9	21,25
2	180BASE500	8024648067258	4	Clips for tiles thickness from 3 to 12 mm (1/8"-1/2")	500	1,5 mm - 1/16"	•	-	-	60x40xh31	9	40,30
2	180BASE2000	8024648069801	1	Clips for tiles thickness from 3 to 12 mm (1/8"-1/2")	2000	1,5 mm - 1/16"	•	-	-	30x40xh43	8,8	137,40



Pieces per Bag	Diagram 1	Diagram 2	Diagram 3	Diagram 4	Dimensions	Weight	Price
100					60x40xh31	9	8,90
250					60x40xh31	9	21,25
500					60x40xh31	9	40,30
2000					30x40xh43	8,8	137,40

**R.L.S. CLIPS 3-12 mm
JOINT 3 mm**

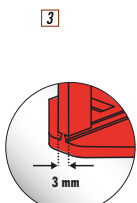
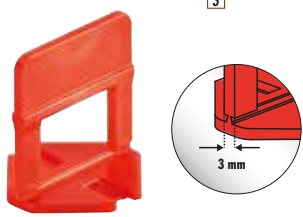

3	180BS0003C0250	8024648081308	8	Clips for tiles thickness from 3 to 12 mm (1/8"-1/2")	250	3 mm - 1/8"	•	-	-	60x40xh31	9,4	21,25
3	180BS0003C0500	8024648081315	4	Clips for tiles thickness from 3 to 12 mm (1/8"-1/2")	500	3 mm - 1/8"	•	-	-	60x40xh31	9,2	40,30
3	180BS0003C2000	8024648081322	1	Clips for tiles thickness from 3 to 12 mm (1/8"-1/2")	2000	3 mm - 1/8"	•	-	-	30x40xh43	8,8	137,40



Pieces per Bag	Diagram 1	Diagram 2	Diagram 3	Diagram 4	Dimensions	Weight	Price
250					60x40xh31	9,4	21,25
500					60x40xh31	9,2	40,30
2000					30x40xh43	8,8	137,40

**R.L.S. CLIPS 3-12 mm
JOINT 4 mm**

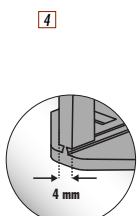
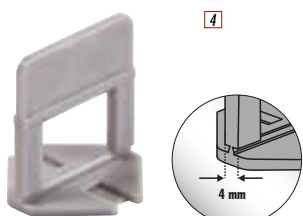

4	180BS0004C0250	8024648081339	8	Clips for tiles thickness from 3 to 12 mm (1/8"-1/2")	250	4 mm - 5/32"	•	-	-	60x40xh31	9,7	21,25
4	180BS0004C0500	8024648081346	4	Clips for tiles thickness from 3 to 12 mm (1/8"-1/2")	500	4 mm - 5/32"	•	-	-	60x40xh31	9,8	40,30
4	180BS0004C2000	8024648081353	1	Clips for tiles thickness from 3 to 12 mm (1/8"-1/2")	2000	4 mm - 5/32"	•	-	-	30x40xh43	9,2	137,40



Pieces per Bag	Diagram 1	Diagram 2	Diagram 3	Diagram 4	Dimensions	Weight	Price
250					60x40xh31	9,7	21,25
500					60x40xh31	9,8	40,30
2000					30x40xh43	9,2	137,40

**R.L.S. CLIPS 12-20 mm
JOINT 1,5 mm**

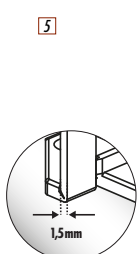
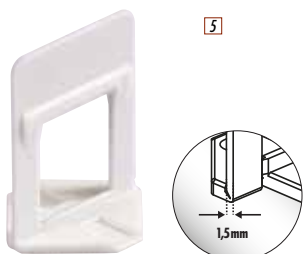

5	180BA200H20	8024648069627	8	Clips for tiles thickness from 12 to 20 mm (1/2"-3/4")	200	1,5 mm - 1/16"	•	-	-	60x40xh31	9	20,00
5	180BA400H20	8024648070050	4	Clips for tiles thickness from 12 to 20 mm (1/2"-3/4")	400	1,5 mm - 1/16"	•	-	-	60x40xh31	9	37,90
5	180BA1500H20	8024648064127	1	Clips for tiles thickness from 12 to 20 mm (1/2"-3/4")	1500	1,5 mm - 1/16"	•	-	-	30x40xh43	7,1	125,00



Pieces per Bag	Diagram 1	Diagram 2	Diagram 3	Diagram 4	Dimensions	Weight	Price
200					60x40xh31	9	20,00
400					60x40xh31	9	37,90
1500					30x40xh43	7,1	125,00

**TILES CHIPPING (AND SCRATCHING) PREVENTING
PLATFORM + MULTI-SIZE SPACER (1,5,2 & 3 mm)**



6	180AGS0250	8050532007437	4	Tiles chipping (and scratching) preventing platform and multi-size spacer	250 pcs bucket	49x39xh 25	5	39,70
---	-------------------	---------------	---	---	----------------	------------	---	--------------



pcs per box	Dimensions	Weight	Price
250 pcs bucket	49x39xh 25	5	39,70

R.L.S. VITE - CAP





1	180VGH0100	8050532003026	12	R.L.S. VITE cap - 100 pcs bags	100	60x40x h31	9,7	19,00
	180VGH0300	8050532003033	4	R.L.S. VITE cap - 300 pcs bags	300	60x40x h31	9,6	53,90
	180VGH0900	8050532004276	1	R.L.S. VITE cap - 900 pcs box	900	30x40x h42	7,9	148,90



R.L.S. VITE - CLIPS 3-15 mm JOINT 1 mm

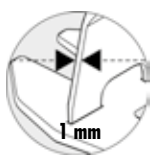

2	180VB010C0100	8050532002982	30	R.L.S. Vite clips for tile thickness 3/15 - 100 pcs bags	100	1 mm - 1/32"	60x40x h31	7,2	7,40
	180VB010C0300	8050532002999	12	R.L.S. Vite clips for tile thickness 3/15 - 300 pcs bags	300	1 mm - 1/32"	60x40x h31	8,3	21,30
	180VB010C3000	8050532003002	1	R.L.S. Vite clips for tile thickness 3/15 - 3000 pcs box	3000	1 mm - 1/32"	30x40x h42	6,7	172,00

R.L.S. VITE - CLIPS 14-26 mm JOINT 1 mm



3	180VBH010C0100	8050532002944	25	R.L.S. Vite clips for tile thickness 14/26 - 100 pcs bags	100	1 mm - 1/32"	60x40x h31	6,6	7,60
	180VBH010C0300	8050532002951	10	R.L.S. Vite clips for tile thickness 14/26 - 300 pcs bags	300	1 mm - 1/32"	60x40x h31	7,5	21,90
	180VBH010C2500	8050532002968	1	R.L.S. Vite clips for tile thickness 14/26 - 2500 pcs box	2500	1 mm - 1/32"	30x40x h42	6,3	147,20





SELF-STOPPING SCRATCH-PREVENTING WASHER FOR R.L.S. VITE



4	180VAGR0100	8050532007239	1	Self-stopping scratch-preventing washer for R.L.S. VITE, 100 pcs.	-	-	-	-	88% "
---	-------------	---------------	---	---	---	---	---	---	-------

*FROM JANUARY 2019

REMOVABLE AND REUSABLE DUAL SIZE (JOINT) SPACER 1&3 mm / 2&5 mm



5	282D1-3C300	8050532000636	6	DOUBLE spacer; joint 1 and 3 mm (1/32" - 1/8"). 300 pcs bucket.	JOINT	COLOR	28x50xh27	9,2	14,80
6	282D2-5C300	8050532002432	6	DOUBLE spacer; joint 2 and 5 mm (3/32" - 3/16"). 300 pcs bucket.pz	1 e 3 mm 1/32" & 1/8"	White	28x50xh27	9,7	15,80
					2 e 5 mm 3/32" & 3/16"	Red	28x50xh27	9,7	15,80



ROTOCUNEO



7	162RC30	8050532006775	27	30 Kits "Rotocuneco" bucket (60 spiral-shaped wedges + 30 wedges)	40x60xh 25	7	4,83
---	---------	---------------	----	---	------------	---	------

SPACERS FOR 20 mm (3/4") THICKNESS TILES JOINT 4 mm (5/32")

Type	Pieces	+	•	-	•	-	•	A	B	H				
											mm			
8	313+500	8024648095275	3	+	-	•	-	•	64	64	12	59x30xh40	9,2	56,00
8	313+200	8024648095268	8	+	-	•	-	•	64	64	12	59x30xh40	9,7	21,60
9	313T500	8024648095299	5	+	-	•	-	•	64	34	12	59x30xh40	11,4	47,00
9	313T200	8024648095282	12	+	-	•	-	•	64	34	12	59x30xh40	11	19,20



10 mm - 13/32"



Type	Pieces							A	B	H							
								mm									
1 193+1000	8024648001306	12	+	1000	•	-	•	-	•	-	•	40	40	7	62x42xh54	26,5	20,66
1 204+200	8024648001641	25	+	200	-	•	•	-	•	-	•	40	40	7	48x46xh28	10,6	5,68
2 204R200	8024648001634	10	↑	200	-	•	-	•	•	-	-	50	50	13	48x46xh28	9,2	8,58
3 193T1000	8024648001313	12	⊥	1000	•	-	•	-	•	-	•	40	25	7	62x42xh54	20,2	20,66
3 204T200	8024648001658	25	⊥	200	-	•	-	•	-	•	-	40	25	7	48x35xh28	7,4	5,68
4 204T200A	8024648001665	10	⊥	200	-	•	-	•	-	-	-	50	30	13	48x35xh28	6,6	7,24

9 mm - 11/32"



Type	Pieces							A	B	H							
								mm									
5 129+1000	8024648001337	12	+	1000	•	-	-	•	•	-	-	50	50	7	62x42xh54	32,2	27,80
5 128+200	8024648001672	25	+	200	-	•	-	•	•	-	-	50	50	7	48x46xh28	13,6	6,00
6 129T1000	8024648001344	12	⊥	1000	•	-	-	•	•	-	-	50	30	7	62x42xh54	26,7	27,40
6 128T200	8024648001689	25	⊥	200	-	•	-	•	•	-	-	50	30	7	48x35xh28	10,6	6,00

8 mm - 5/16"



Type	Pieces							A	B	H							
								mm									
7 372+1000	8024648001351	12	+	1000	•	-	•	-	-	•	-	40	40	7	62x42xh54	23,1	17,00
7 376+200	8024648001696	25	+	200	-	•	•	-	-	•	-	40	40	7	48x46xh28	9,6	4,00
8 372T1000	8024648001368	8	⊥	1000	•	-	-	•	-	-	•	40	25	7	46x41xh32	12,7	16,20
8 376T200	8024648001702	25	⊥	200	-	•	•	-	-	•	-	40	25	7	48x35xh28	7,6	4,00

7 mm - 9/32"

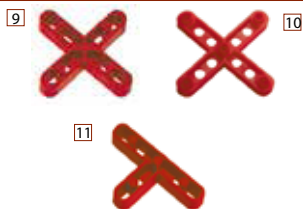

Type	Pieces							A	B	H							
								mm									
9 152+1000E	8024648001375	12	+	1000	•	-	•	-	-	•	-	40	40	7	62x42xh54	26,0	17,20
10 152+1000L	8024648001382	16	+	1000	•	-	•	-	-	•	-	40	40	5	62x42xh45	18,4	12,92
9 151+200E	8024648001719	25	+	200	-	•	•	-	-	•	-	40	40	7	48x46xh28	10,6	3,90
10 151+200L	8024648001726	25	+	200	-	•	•	-	-	•	-	40	40	5	48x35xh28	5,6	3,30
11 152T1000E	8024648001399	8	⊥	1000	•	-	-	•	-	-	•	40	25	7	46x41xh32	13,3	15,18
11 151T200E	8024648001733	30	⊥	200	-	•	•	-	-	•	-	40	25	7	48x35xh28	9,6	3,90

6 mm - 1/4"



Type	Pieces							A	B	H							
								mm									
12 154+1000	8024648001405	12	+	1000	•	-	-	•	•	-	-	50	50	7	62x42xh54	18,8	17,20
12 153+200	8024648001740	25	+	200	-	•	-	•	•	-	-	50	50	7	48x46xh28	8,1	4,00
13 154T1000	8024648001412	8	⊥	1000	•	-	-	•	•	-	-	50	28	7	46x41xh32	10,9	18,20
13 153T200	8024648001757	30	⊥	200	-	•	-	•	•	-	-	50	28	7	48x35xh28	8,1	4,00

5 mm - 3/16"



Type	Pieces							A	B	H							
								mm									
14 156+1000L	8024648001436	16	+	1000	•	-	•	-	-	•	-	40	40	5	62x42xh45	16,8	12,40
15 156+1000	8024648001450	12	+	1000	•	-	-	•	•	-	-	50	50	6	62x42xh54	15	15,80
16 156R1000S	8024648008329	10	↑	1000	-	•	-	•	•	-	-	50	50	7	62x42xh45	13,8	18,08
14 155+200L	8024648001771	30	+	200	-	•	•	-	-	•	-	40	40	5	48x35xh28	5,6	3,10
15 155+200	8024648001795	25	+	200	-	•	-	•	•	-	-	50	50	6	48x46xh28	5,6	3,60
16 155R200	8024648001764	20	↑	200	-	•	-	•	•	-	-	50	50	7	48x46xh28	6,6	4,54
17 156T1000E	8024648001443	16	⊥	1000	•	-	-	•	-	-	•	35	20	5	46x41xh32	14,1	12,40
18 156T1000	8024648001467	8	⊥	1000	•	-	-	•	•	-	-	50	28	6	46x41xh32	8,1	16,60
17 155T200E	8024648001788	40	⊥	200	-	•	•	-	-	•	-	35	20	5	32x32xh28	6,8	3,10
18 155T200	8024648001801	30	⊥	200	-	•	-	•	•	-	-	50	28	6	48x35xh28	6,0	3,60

4 mm - 5/32"



Type	Pieces							A	B	H							
								mm									
19 158+1000	8024648001481	24	+	1000	•	-	•	-	-	•	-	38	38	4	62x42xh45	20,7	12,40
20 158R1000	8024648008435	16	↑	1000	•	-	-	•	-	•	-	30	30	6	62x42xh45	22,4	19,00
19 157+200	8024648001825	50	+	200	-	•	-	•	-	•	-	38	38	4	48x35xh28	8,6	3,10
20 157R200	8024648001818	25	+	200	-	•	-	•	-	•	-	30	30	6	32x32xh28	6,9	4,34
21 158T1000	8024648001498	16	⊥	1000	•	-	-	•	-	-	•	38	20	4	46x41xh32	10,1	12,40
21 157T200	8024648001832	40	⊥	200	-	•	•	-	-	•	-	38	20	4	32x32xh28	5,2	3,10

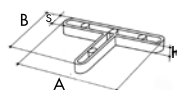
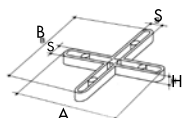

NEW SPACERS

TWO NEW "T" MODELS
AND TWO NEW MODELS FOR SPECIAL FORMATS "RHOMBUS"

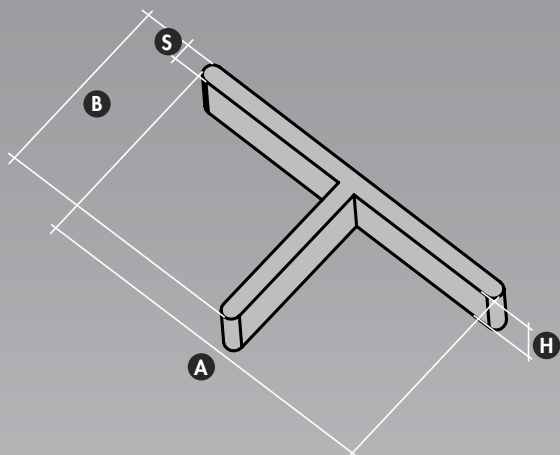
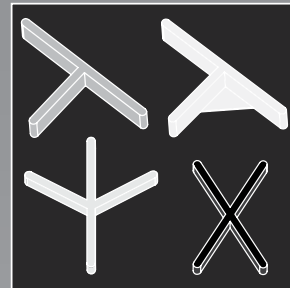

art. **132T200AL**

-	TYPE	T
A	LENGTH	38 mm
H	HEIGHT	7 mm
S	THICKNESS	2 mm
B	WIDTH	20 mm
	WING	NO
	BAG	200 pcs
	BAGS PER BOX	30 pcs
€	PRICE (200pcs)	€ 2,25

art. **133T1000AL**
1000 pcs packaging

	LITTLE BOX	1000 pcs
	LITTLE BOXES PER CARDBOARD	16 pcs
€	PRICE (1000pz)	€ 11,00

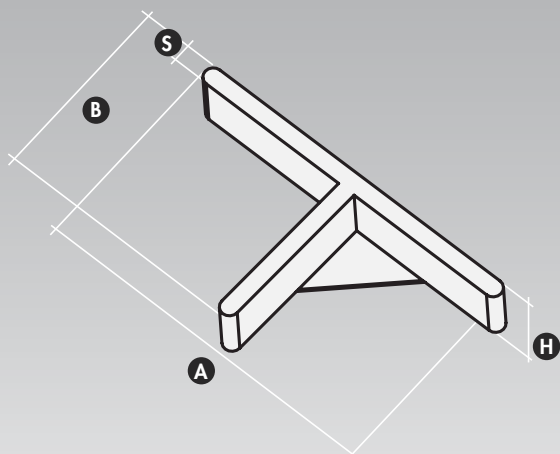

art. **132T200ALR**



-	TYPE	T
A	LENGTH	38 mm
H	HEIGHT	7 mm
S	THICKNESS	2 mm
B	WIDTH	20 mm
	WING	YES
	BAG	200 pcs
	BAGS PER BOX	30 pcs
€	PRICE (200pcs)	€ 2,25

art. **133T1000ALR**
1000 pcs packaging

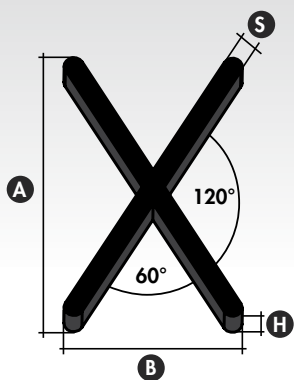
	LITTLE BOX	1000 pcs
	LITTLE BOXES PER CARDBOARD	16 pcs
€	PRICE (1000pz)	€ 11,00





art. **161R200**

-	TYPE	X
A	LENGTH	30,6 mm
H	HEIGHT	3,5 mm
S	THICKNESS	2 mm
B	WIDTH	18,5 mm
	WING	NO
	BAG	200 pcs
	BAGS PER BOX	40 pcs
€	PRICE (200pcs)	€ 1,80

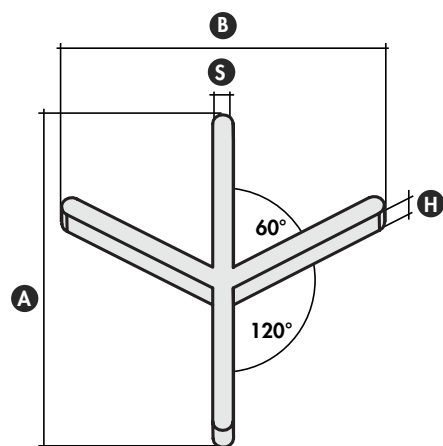
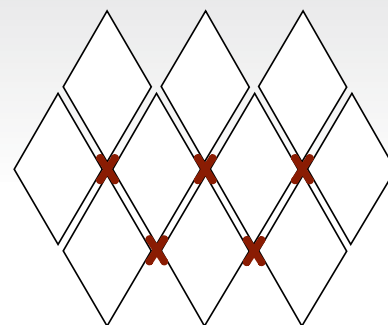
tile pattern layout



art. **161Y200G4**

-	TYPE	Y
A	LENGTH	35 mm
H	HEIGHT	3,5 mm
S	THICKNESS	2 mm
B	WIDTH	31,5 mm
	WING	NO
	BAG	200 pcs
	BAGS PER BOX	40 pcs
€	PRICE (200pcs)	€ 1,80

tile pattern layout

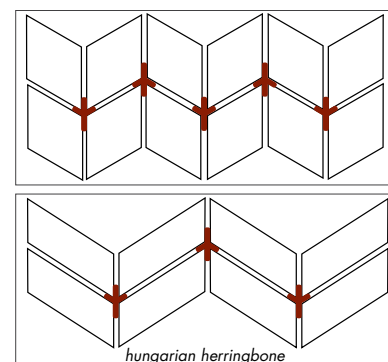



3 mm - 1/8"

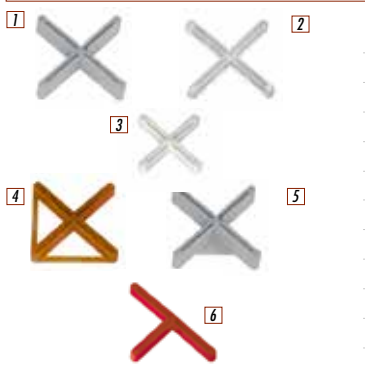

Type	Pieces	Icons	A	B	H	mm					
160+T1000	8024648008831	16	+ / -	1000	• - • - • - • -	38	38	8	62x42xh45	19,6	#1S"
160+1000	8024648001528	24	+	1000	• - • - • - • -	38	38	3,5	62x42xh45	17,6	##A%
160+1000E	8024648001542	32	+	1000	• - • - • - • -	28	28	3	42x42xh40	14,0	*1E"
160R1000	8024648008572	16	+	1000	• - • - • - • -	38	38	3,5	62x42xh45	14,3	##S&
160+1000A	8024648005960	16	+ / -	1000	• - • - • - • -	38	38	8	62x42xh45	18,8	#1I"
159+T200	8024648008534	30	+ / -	200	- • • - - • • -	38	38	8	48x35xh28	6,6	%6-\$
159+200	8024648001863	50	+	200	- • • - - • • -	38	38	3,5	48x35xh28	6,6	\$1)*
159+200E	8024648001887	60	+	200	- • • - - • • -	28	28	3	32x32xh28	4,9	\$1\$*
159R200	8024648001856	40	+	200	- • • - - • • -	38	38	3,5	48x35xh28	6,6	%6\$*
159+200A	8024648005977	30	+ / -	200	- • • - - • • -	38	38	8	48x35xh28	7,5	\$1\$*
160T1000	8024648001535	16	-	1000	• - • - • - • -	38	20	3,5	46x41xh32	8,5	##A%
159T200	8024648001870	40	-	200	- • • - - • • -	38	20	3,5	32x32xh28	4,0	\$1)*

2 mm - 3/32"

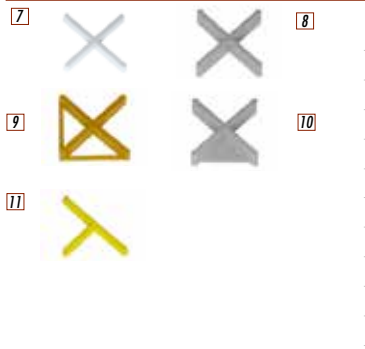

Type	Pieces	Icons	A	B	H	mm					
133+1000	8024648001566	32	+	1000	• - • - • - • -	28	28	2,8	42x42xh40	11,2	#19\$
133+1000A	8024648008749	16	+	1000	• - • - • - • -	28	28	7	46x41xh32	11,4	##A* *
133R1000	8024648008671	16	+	1000	• - • - • - • -	28	28	2,8	62x42xh45	8,1	##S&
133R1000A	8024648014030	16	+	1000	• - • - • - • -	28	28	7	62x42xh45	11,2	##S&
132+200	8024648001900	50	+	200	- • • - - • • -	28	28	2,8	32x32xh28	3,4	\$1)*
132+200A	8024648004604	30	+	200	- • • - - • • -	28	28	7	32x32xh28	4,2	\$1+*
132R200	8024648001894	40	+	200	- • • - - • • -	28	28	2,8	32x32xh28	15,6	%6\$*
132R200A	8024648015365	30	+	200	- • • - - • • -	28	28	7	32x32xh28	4,5	%6+*
133T1000	8024648001573	32	-	1000	• - • - • - • -	28	16	2,8	42x42xh40	8,9	#19\$
132T200	8024648001917	50	-	200	- • • - - • • -	28	16	2,8	32x32xh28	2,4	\$1)*
132T200A	8024648004611	40	-	200	- • • - - • • -	28	16	7	32x32xh28	2,4	\$1+*

1,5 mm - 1/16"



Type	Pieces	Icons	A	B	H	mm					
131+1000	80246480060808	16	+	1000	• - • - • - • -	33	33	5	62x42xh45	8	##A**
131+200	80246480060815	30	+	200	- • • - - • • -	33	33	5	46x41xh32	3	%6**

1 mm - 1/32"

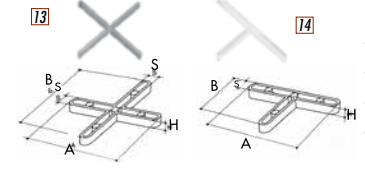

Type	Pieces	Icons	A	B	H	mm					
143+1000	8024648004581	32	+	1000	• - • - • - • -	28	28	3	42x42xh40	7,0	##A**
143+200	8024648004628	50	+	200	- • • - - • • -	28	28	3	32x32xh28	1,9	%6**
143T1000	8024648017796	32	-	1000	• - • - • - • -	32	16	4	42x42xh40	7,1	##A**
143T200	8024648017802	50	-	200	- • • - - • • -	32	16	4	23x32xh28	2,0	%6**

OCTAGONAL 3 mm - 1/8"



Type	Pieces	Icons	A	B	H	mm					
161Y200	8024648001924	40	Y	200	- • • - - • • -	-	-	6	32x32xh28	3,6	%6**

HEXAGONAL 3 mm - 1/8"



Type	Pieces	Icons	A	B	H	mm					
161E200	8024648001931	40	Y	200	- • • - - • • -	-	-	5	32x32xh28	4,4	%6**

PROVENZALE 3 mm - 1/8"



Type	Pieces	Icons	A	B	H	mm					
161P200	8024648001948	40	T	200	- • • - - • • -	-	-	6	32x32xh28	4,4	%6**

CANINI / WEDGES

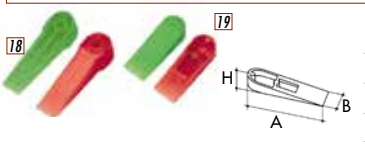

Type	Pieces	Icons	A	B	H	mm					
163G1000	8024648001610	18	▲	1000	- • • - - • • -	40	9	8	62x42xh45	20,5	##A+8
163P1000	8024648001627	32	▲	1000	• - • - • - • -	28	10	6	42x42xh40	18,2	#1*8
162G200	8024648001955	25	▲	200	- • • - - • • -	40	9	8	32x32xh28	4,2	\$1**
162P200	8024648001962	50	▲	200	- • • - - • • -	28	10	6	32x32xh28	5,4	\$1)8

FLOATING FLOORS SUPPORTS



Type	Pieces	Icons	S	Ø	H	mm				
312P300	8024648009845	1	○	Floating floors supports (300 Pieces)	4	150	27	65x45xh45	27,4	69,80

SALVA SPIGOLO



CORNER PROTECTOR



Siamo lieti di presentarvi un nuovo prodotto studiato principalmente per piastrelle di grande formato ma adatto a tutti i tipi di piastrelle nonchè per vetro o altri materiali.

Stiamo parlando di un nuovo protettore per gli angoli delle piastrelle (Salvaspigholi).

Il nostro Salvaspigholi è idoneo per piastrelle di spessore da 3 mm fino a 12 mm.

Quindi, un solo prodotto copre praticamente tutti gli spessori attualmente in commercio di lastre di grande formato.

We are glad to introduce you a new product studied mainly for large format tiles but suitable for all kind of tiles. Even for glass or other materials.

We're speaking about a new corner protector.

Raimondi corner protector is suitable for tile of thickness from 3 mm (1/8") up to 12 mm (1/2").

So, just one product basically covers all large format tiles thicknesses.

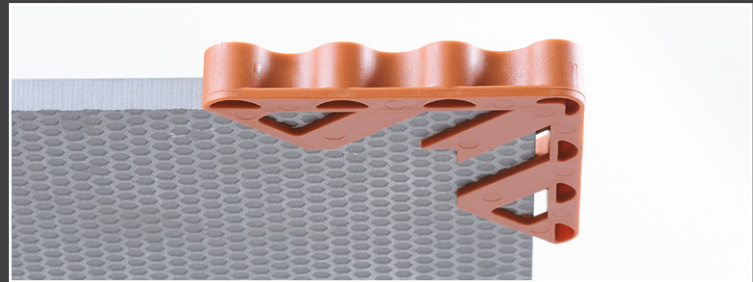
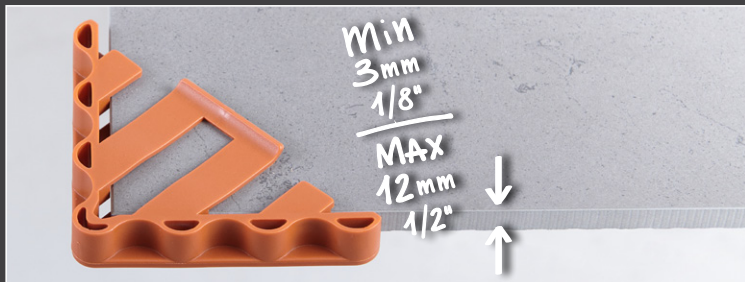

L'inserimento del prodotto sullo spigolo è facile e veloce. Una volta inserito, rimane saldamente in posizione grazie ad una clip che ne mantiene il sostegno sullo spigolo.

Inserting the product on the corner is easy and fast. Once inserted, it firmly remains into position, thanks to a clip that maintains its support on the corner.

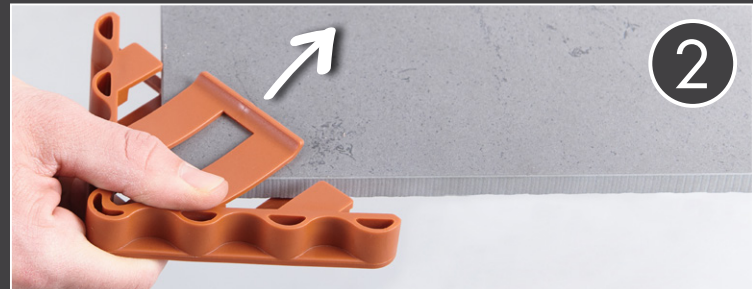

I salvaspigholi sono molto importanti specialmente quando si movimentano lastre di grande formato per evitare potenziali rotture delle parti più delicate, ovvero gli angoli (e i bordi).

Pertanto, abbiamo ritenuto opportuno inserirli nel nostro catalogo per arricchire ulteriormente la nostra offerta e continuare così ad offrire al mercato la gamma di prodotti professionali più ampia per l'installazione di piastrelle di grande formato.

Il paraspigholo è venduto in un blister da 4 pezzi in una scatola di cartone contenente 8 blister.

Corner protectors are very important when handling large format tiles to avoid potential damages to the most delicate parts of the slab (the corners indeed - and the edges).

Therefore, we felt like further completing our range with the introduction of this product aiming to keep on offering the market the widest and most professional tools portfolio for large format tiles installation.

The corner protector is sold into a 4 pieces transparent blister into a carton box containing 8 blisters.



BLISTER 4 pz
4 pcs BLISTER

Art. Item Code	Barcode	Box	Descrizione Description	Weight	Dimensions	Weight	LISTINO PRICE LIST
432SSBRAI	8050532008700	8	Salvaspigholo (blister 4pz) Corner protector (4pcs blister)	0,7 Kg 1.5 lbs	32x32xh 8 cm 12 2/3"x12 2/3"xh 3"	1,2 Kg 2.6 lbs	€ 11,00

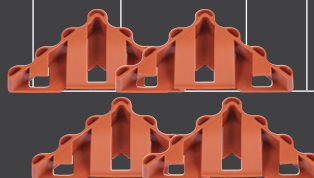

DISPONIBILE | AVAILABLE



BI-DIRECTIONAL TILE CUTTERS



1

1	254RAI75	8024648005083	1	RAIMO 75 Tile cutter
1	254RAI63	8024648005090	1	RAIMO 63 Tile cutter

	75 cm	53x53 cm	106x40xh25	11	329,00
	63 cm	44x44 cm	106x40xh25	10	272,00

SPARE PARTS

	255IMPCOM	8024648005120	1	Complete grip for Raimo 75/63/52/44	37x20xh7	0,6	38,20
	255SQU75	8024648005182	1	Square for art.254RAI 75	-	1,1	78,30
	255SQU63	8024648005199	1	Square for art.254RAI 63	-	1,1	75,90

PUSH TILE CUTTERS



2

2	254RAI125 S	8024648097187	1	RAIMO 125 S Tile cutter
3	254RAI93 S	8024648097194	1	RAIMO 93 S Tile cutter
4	254RAI75 S	8024648014542	1	RAIMO 75 S Tile cutter
4	254RAI63 S	8024648014559	1	RAIMO 63 S Tile cutter

	125 cm	88x88 cm	166x44xh26	21	630,00
	93 cm	66x66 cm	124x40xh23	23,1	380,00
	75 cm	53x53 cm	106x40xh25	11	345,00
	63 cm	44x44 cm	106x40xh25	10	310,00



3



4

SPARE PARTS

	255M445PR	8024648097255	1	Complete grip for Raimo 125S "push"	-	1	61,70
	255M445P	8024648014580	1	Complete grip for Raimo 93S/75S/63S/52S/44S "push"	37x20xh7	0,8	59,15
	255456P	8024648014597	1	Goniometric square for art.254RAI 75 S	-	1,1	72,00

CUTTING WHEELS

	13514	8024648005137	12	Ø 14 mm wolfram carbide wheel with spindle	24x17xh1	0,1	6,95
	13514TITA	8024648005144	12	Ø 14 mm TITANIUM wheel with spindle	24x17xh1	0,1	9,50



RAIZOR - CUTTING SYSTEM FOR LARGE FORMAT TILES



1	433CR R	8050532001312	1	RAIZOR - complete cutting system for cutting up to 332 cm (10.9 ft): • two connectable guides with cutting length of 160 cm (5.2 ft.) each; • die-cast cutting unit provided w/wolfram carbide wheel Ø 16 mm (5/8") and pin on bearings; • cutting-off pliers for tiles/slabs with thickness from 3 to 6 mm (1/8" - 1/4") • padded bag with shoulder-straps and provided with inside modular compartments and pocket	180x25xh 16	9,5) +\$25\$
2	433CRP100	8050532003019	1	115 cm (3.8 ft.) extension for RAIZOR with 2 stain-free suction cups to reach the cutting length of: • 447 cm (14,7 ft.) combined with RAIZOR guides (each guide's cutting length: 160 cm - 5,2 ft.); • 275 cm (9 ft.) combined with just one RAIZOR guide (guide's cutting length: 160 cm - 5,2 ft.); • 103 cm (3.4 ft.) if used alone	127x18xh 12	3,3	&& Z\$S

ACCESSORIES AND SPARE PART FOR RAIZOR



3	169TR01A	8024648078063	1	Cutting-off pliers for tile/slab with max thickness of 6 mm (1/4") - spare part-		-	35,00
4	169TM01AN	8024648067470	1	Cutting-off pliers for tile/slab with thickness 6 (1/4") up to 20 mm (3/4") 38x18xh 8	33x17x h 8	1,5	95,00
	135D16A	8024648073419	1	Wolfram carbide wheel Ø 16 mm (5/8") with pin	-	-	9,50

POWER RAIZOR - MULTI-ANGLE CUTTING UNIT WITH ANGLE GRINDER



5	433PWR EU	8050532003088	1	POWER RAIZOR Multi-angle cutting unit with angle grinder 900W 230V 50/60Hz and turbo diamond disc Ø 125 mm (5"). Arbor sizes: M14 (metric).	M14	39x39xh14	6,9	562,00
6	433PWROHR	8050532003170	1	POWER RAIZOR Multi-angle cutting unit. Without angle grinder, without disc. Arbor sizes: M14 (metric).	M14	39x39xh14	6,9	342,00
6	433PWROHUS	8050532004467	1	POWER RAIZOR Multi-angle cutting unit. Without angle grinder, without disc. Arbor sizes: 5/8"-11 (imperial).	5/8"-11	39x39xh14	4,3	342,00
7	179CCT125	8024648075703	1	Turbo diamond disc Ø 125 mm (5") (f22,2 mm)	-	-	-	55,00
8	179FLEX010SE	8024648094834	1	1/2 bullnose wheel, radius 10 mm (3/8") - dry use	10 mm - 3/8"	milling	120 mm 4-3/4"	200,00
8	179FLEX006SE	8024648094841	1	1/2 bullnose wheel, radius 6 mm (1/4") - dry use	6 mm - 1/4"	milling	120 mm 4-3/4"	187,00



ACCESSORIES FOR POWER RAIZOR



9	433PWW A	8050532004573	1	Kit for wet cut and dust suppression	and/or	58x30xh25	2,4	90,00
10	433PWZP A	8050532004412	1	Dust containment device	any angle grinder model	27x15xh10	0,5	69,00

FREE-CUT: CUTTING SYSTEM FOR LARGE FORMAT TILES



2	169FC150N	8024648081094	1 "FREE-CUT" cutting guide. Maximum cutting length 156 cm (5.2'). Equipped with: • Cutting-off pliers for tile/slab with max thickness of 6 mm (1/4") • Complete cutting-unit (wheel Ø 16 mm - 5/8" included) • Side squares • Carrying case for pliers, cutting-unit and side squares	180xØ17 + 39x39xh14	13	(-) 325
7	169FC200N	8024648085528	1 "FREE-CUT" cutting guide. Maximum cutting length 206 cm (6.8'). Equipped with: • Cutting-off pliers for tile/slab with max thickness of 6 mm (1/4") • Complete cutting-unit (wheel Ø 16 mm - 5/8" included) • Side squares • Carrying case for pliers, cutting-unit and side squares	227x Ø17 + 39x39xh 14	18)') 325
2	169FC150PN	8024648084934	1 "FREE-CUT" extension. Length 170 cm (5.6'). To reach the maximum cutting length of: • 326 cm (10.7') in combination with art. code 169FC150 ("FREE-CUT" guide 156 cm) • 376 cm (12.3') in combination with art. code 169FC200 ("FREE-CUT" guide 206 cm)	180xØ17	10	' * 325
1	169FC200PN	8024648084958	1 "FREE-CUT" extension. Length 220 cm (7.2'). To reach the maximum cutting length of: • 376 cm (12.3') in combination with art. code 169FC150 ("FREE-CUT" guide 156 cm) • 426 cm (14') in combination with art. code 169FC200 ("FREE-CUT" guide 206 cm)	227x Ø17	15	(325

ACCESSORIES AND SPARE PART FOR FREE-CUT



3	169TR01A	8024648078063	1 Cutting-off pliers for tile/slab with max thickness of 6 mm (1/4") - spare part	•	•	-
4	169TM01AN	8024648067470	1 Cutting-off pliers for tile/slab with thickness 6 (1/4") up to 20 mm (3/4")	•	•	33x17xh 8
1	13512A	8024608079824	1 Wolfram carbide wheel Ø 12 mm (1/2") with pin (spare part for FREE-CUT version with metal cutting unit)	-	•	-
1	135D16A	8024648073419	1 Wolfram carbide wheel Ø 16 mm (5/8") with pin	•	-	-
5	169GP	8024648086037	1 Pair of vacuum suction cups kits	•	•	33x33xh 10
						35,00
						95,00
						6,50
						9,50
						290,00

FREE-FLEX: CUTTING UNIT WITH ANGLE GRINDER

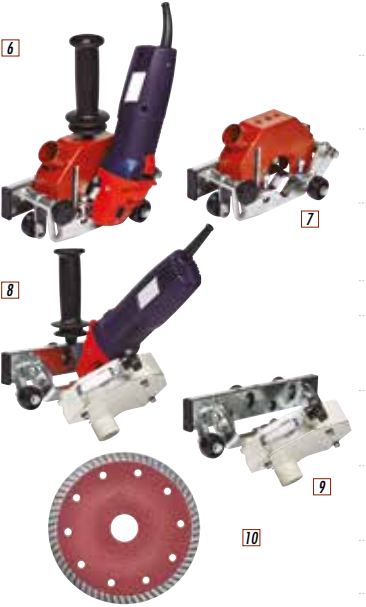

6	169GTE 230V	8024648082527	1 FREE-FLEX 90° Plunge-cutting unit 90° with angle grinder 900W 230V 50/60 Hz and turbo diamond disc Ø 125 mm (5")	Ⓜ	•	-
6	169GTE 110V	8024648091987	1 FREE-FLEX 90° Plunge-cutting unit 90° with angle grinder 900W 110V 60 Hz and turbo diamond disc Ø 125 mm (5")	•	-	40x28xh25
6	169GTE 110GB	8024648095831	1 FREE-FLEX 90° Plunge-cutting unit 90° with angle grinder 900W 110V 50 Hz and turbo diamond disc Ø 125 mm (5")	•	-	40x28xh25
7	169GTE OH	8024648086457	1 Plunge-cutting unit 90° without angle grinder. Without disc.	•	-	40x28xh25
8	169GTJ 230V	8024648086471	1 FREE-FLEX 35°/55° Variable angle cutting unit with angle grinder 900W 230V 50/60 Hz and turbo diamond disc Ø 125 mm (5")	Ⓜ	-	40x28xh25
8	169GTJ 110V	8024648091994	1 FREE-FLEX 35°/55° Variable angle cutting unit with angle grinder 900W 110V 50 Hz and turbo diamond disc Ø 125 mm (5")	-	•	40x28xh25
8	169GTJ 110GB	8024648095848	1 FREE-FLEX 35°/55° Variable angle cutting unit with angle grinder 900W 110V 50 Hz and turbo diamond disc Ø 125 mm (5")	-	•	40x28xh25
9	169GTJ OH	8024648083173	1 35°/55° variable angle cutting unit without angle grinder. Without disc.	-	•	40x28xh25
10	179CCT125	8024648075703	1 Turbo diamond disc Ø 125 mm - 5" (f 22,2 mm) - dry use	-	-	-
						410,00
						410,00
						415,00
						215,00
						398,00
						398,00
						403,00
						205,00
						55,00

PROFILING DEVICE AND WHEELS FOR 1/2 BULLNOSE



11	169GSAG 230V	8024648094780	1 Profiling device with angle grinder 1400W 230V 50/60 Hz without wheel	40x28xh25	7,1	465,00
12	169GSAG OH	8024648061515	1 Profiling device without angle grinder, without wheel	40x28xh25	4,2	245,00

Important: it is suggested to use angle grinders with a speed of 4.000 rpm and an approximate power of 1400 W.

13	179FLEX010SE	8024648094834	1 1/2 bullnose wheel, radius 10 mm (3/8") - dry use	USE	120 mm - 4 3/4"	200,00
13	179FLEX006SE	8024648094841	1 1/2 bullnose wheel, radius 6 mm (1/4") - dry use		120 mm - 4 3/4"	187,00



BM180 PLUS - ADJUSTABLE WIDTH (100-150 cm / 3.3'-5') TABLE FOR LARGE FORMAT TILES



7	394MA PLUS	8050532007062	1 "BM180 PLUS" adjustable width (100-150 cm / 3.3'-5') table with folding legs for large format tiles	190x21x h 10 + 117x20x h 20	39,6	615,00
	394PT01D3A	8050532007321	1 Anodized aluminum profile for BM180 PLUS	185xØ 10	3,5	60,00

min: 100 cm
max: 150 cm



BM180 MKII - TABLE FOR LARGE FORMAT TILES



2	394MA RAI	8050532000995	1 "BM180 MKII" table with folding legs for large format tiles	190x21x h 10 + 117x20x h 20	30,9	468,00
----------	------------------	---------------	---	--------------------------------	------	---------------

90 cm



BM180 MKII EXTENSIONS



3	394CP240A	8050532000599	1 Side extension complete with 6 aluminum profiles and folding legs to lengthen the bench of 90 cm (35 1/2") 140x14xh 8	7,2	130,00
----------	------------------	---------------	---	-----	---------------



4	394CP270A	8050532005136	1 Pair of side telescopic extensions to lengthen the bench up to 30 cm (12") each side (60 cm - 24" tot)	117x20x h20	12,5	227,00
----------	------------------	---------------	--	-------------	------	---------------



1 pz art. 394CP240A
worktop dimension: 240x90 cm (7.9'x3')



2 pz art. 394EST 01A
worktop dimension: 360x150 cm (11.8'x5')



1 pz art. 394CP270A
worktop dimension: 270x90 cm (8.9'x3')

OTHER ACCESSORIES FOR BM180 MKII AND BM180 PLUS



6	394CC 01A	8050532004207	1 Kit of 20 tile-support cylinders	39x39xh 15	1,2	49,00
----------	------------------	---------------	------------------------------------	------------	-----	--------------



7	394IS 1200	8050532007024	1 Side profile for scoring and cut. Length 124 cm (4')	-	-	64,50
----------	-------------------	---------------	--	---	---	--------------



7	394IS 1600	8050532007031	1 Side profile for scoring and cut. Length 164 cm (5.4')	-	-	72,50
----------	-------------------	---------------	--	---	---	--------------



8	394BLOIACP	8024648096678	1 Stand-alone tile holder (for 3 to 30 mm thicknesses)	27x15xh 10	1	65,00
----------	-------------------	---------------	--	------------	---	--------------

9	394PM02ACP	8024648096722	1 Strips support (length: 12 cm - 4 3/4") - pair	27x15xh 10	0,7	20,90
----------	-------------------	---------------	--	------------	-----	--------------

10	394CR R	8050532000940	1 Pair of wheels for legs	27x15xh 10	1,8	44,00
-----------	----------------	---------------	---------------------------	------------	-----	--------------

11	394GA R	8050532000971	1 Kit of 4 supports for in-legs shelf (shelf not provided)	27x15xh 10	1,2	21,90
-----------	----------------	---------------	--	------------	-----	--------------

12	394CA 01A	8050532002364	1 Kit of 4 lateral steel hooks for hang up the cutting guides	33x17xh 8	2	45,00
-----------	------------------	---------------	---	-----------	---	--------------

13	394CB 01A	8050532002388	1 Steel-made side tools box	58x28xh 23	5,4	53,00
-----------	------------------	---------------	-----------------------------	------------	-----	--------------



9

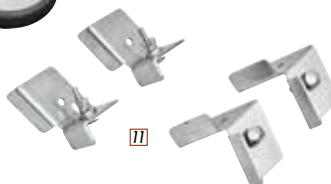

11



12



13

TIP-TOP. FACE-UP MITER-CLAMPING-DEVICE FOR STAIRS AND COUNTERTOPS OF ANY LENGTH

NEW



1	171TG RAI	8050532007062	1	TIP-TOP: face-up miter-clamping-device for stairs and countertops of any length	50x50x17h	8,5 Kg	255,00
----------	------------------	---------------	---	---	-----------	--------	---------------



* 1 pair



* 2 pairs

90° GLUING KIT (FOR STEPS AND COUNTERTOP)

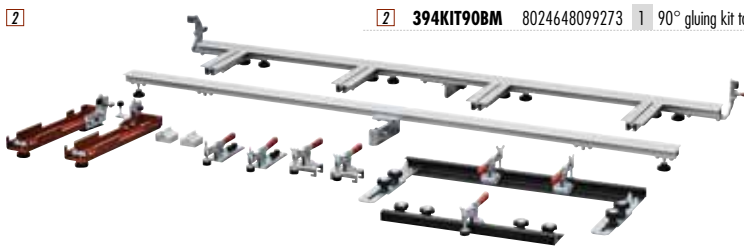

2	394KIT90BM	8024648099273	1	90° gluing kit to create steps and countertop	213x46xh 15	30	785,00
----------	-------------------	---------------	---	---	-------------	----	---------------



BM180^{MA} modular bench not included.

CAM ADV - CART FOR TRASPORT AND STORAGE OF LARGE FORMAT TILES



3	169CML UN	8024648094858	1	CAM ADV - Cart for large format tiles and handling devices and for application of the adhesive in the back of the tile ("back-buttering")	140x43x h 30	34	605,00
----------	------------------	---------------	---	---	--------------	----	---------------

**EASY-MOVE ^{MkIII} (WITH VACUUM SUCTION CUPS WITH GAUGE)**

1	432EM03CA	8050532000650	1 EASY-MOVE ^{MkIII} with 6 "vacuum" (pump) suction cups with vacuum gauge (stain-free-rubber). Telescopic device for handling large format tiles up to 320 cm (10.5') length.	193x46xh 15	28,2	1.255,00
2	432EM03TA	8050532000711	1 EASY-MOVE ^{MkIII} with crossbars with 8 "vacuum" (pump) suction cups with vacuum gauge (stain-free-rubber). Telescopic device for handling large format tiles up to 320 cm (10.5') length.	193x46xh 15+140x14xh 8 +40x40xh 15	39,6	1.710,00

1



2

EASY-MOVE ^{MkIII} (WITH VACUUM SUCTION CUPS)

3	432EM03CV	8050532000674	1 EASY-MOVE ^{MkIII} with 6 "vacuum" (pump) suction cups (stain-free-rubber). Telescopic device for handling large format tiles up to 320 cm (10.5') length.	193x46xh 15 cm	28,2	1.155,00
4	432EM03TV	8050532000735	1 EASY-MOVE ^{MkIII} with crossbars with 8 "vacuum" (pump) suction cups (stain-free-rubber). Telescopic device for handling large format tiles up to 320 cm (10.5') length.	193x46xh 15 +140x14xh 8 +40x40xh 15	39,6	1.580,00

3



4

EASY-MOVE ^{MkIII} (WITH DOUBLE SUCTION CUPS)

5	432EM03CB	8050532000667	1 EASY-MOVE ^{MkIII} with 6 stain-free-rubber double suction cups (12 rubber cups in total). Telescopic device for handling large format tiles up to 320 cm (10.5') length.	193x46xh 15	27,1	550,00
6	432EM03TB	8050532000728	1 EASY-MOVE ^{MkIII} with crossbars with 8 stain-free-rubber double suction cups (16 rubber cups in total). Telescopic device for handling large format tiles up to 320 cm (10.5') length.	193x46xh 15+140x14xh 8 +40x40xh 15	37,9	780,00

5

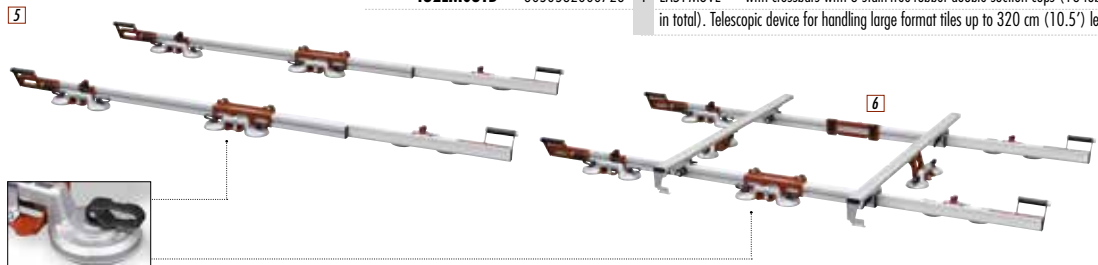

6

ACCESSORIES FOR EASY-MOVE ^{MkIII}

7



7	432E003ID	8050532001022	1 Kit of 4 double grip handles for EASY-MOVE ^{MkIII}	40x40xh 15	4,5	139,00
8	432E003TR	8050532001039	1 Pair of crossbars for EASY-MOVE ^{MkIII}	140x14xh 8	7,7	150,00
9	432E003VB	8050532001053	1 Kit of 2 DOUBLE SUCTION CUPS for EASY-MOVE ^{MkIII} crossbars	33x33xh 10	3	95,00
10	432E003VV	8050532001060	1 Kit of 2 VACUUM (pump) SUCTION CUPS for EASY-MOVE ^{MkIII} crossbars	40x40xh 15	3,6	295,00
11	432E003VA	8050532001046	1 Kit of 2 VACUUM (pump) SUCTION CUPS WITH GAUGE for EASY-MOVE ^{MkIII} crossbars	40x40xh 15	3,6	330,00
12	185V150CP	8050532001039	1 VACUUM (pump) SUCTION CUP with protection	33x33xh 10	1,4	114,00
13	185V150CPVT	8024648019578	1 VACUUM (pump) SUCTION CUP WITH GAUGE with protection	33x33xh 10	1,4	131,00

8



9



10

11

12

13

GENERAL SALES TERMS AND CONDITIONS

GARANTINĖS SĄLYGOS.

Mechanizams su elektriniais varikliais taikoma 1-erių metų gamintojo garantija, kuri pradeda skaičiuoti nuo pirkimo datos. Garantija galioja visiems pagaminimo defektams, atsiradusiems dėl gamintojo kaltės. Garantija netaikoma bet kokiam gedimui, atsiradusiam dėl normalaus naudojimo ar nusidėvėjimo, mechanizmo perkaitimo, neteisingo ar aplaidaus / neatidaus naudojimo, ar kito gedimo, atsiradusio naudojant mechanizmą ne autorizuoto gamintojo techninio departamento ar pačio gamintojo. Ši garantija negalioja remontuotiems mechanizams, kurių sudedamosios dalys yra pakeistos, defektuotos kaip blogos ar sugedusios, ar po mechanizmo patikrinimo paaiškėja, kad mechanizmas buvo naudojamas netinkamu būdu. Garantija taip pat nepadengia mechanizmo transportavimo kaštų. Kiekvienas nusiskundimas gali būti pateiktas tiesioginiam gamintojo atstovui tame regione, kuriame įsigyjote mechanizmą.

Mielas Pirkėjų,

Jeigu reikalingas atitinkamas mechanizmo remontas, susisiekit su tiesioginiu gamintojo atstovu tame regione, kuriame įsigyjote mechanizmą. Jūsų mechanizmas bus remontuojamas nemokamai, jeigu laikysitės ir atitiksime anksčiau nurodytas sąlygas.

Garantinės sąlygos:

1. Garantija mechanizmui galioja ne ilgiau kaip 12 mėnesių nuo pirkimo datos.
2. Pirkimo data laikoma ta data, kuri nurodyta kasos aparato čekyje ar PVM sąskaitoje faktūroje.
3. Bet kokia garantija tampa negaliojančia, jeigu garantinio rašto B dalis nėra užpildoma per 10 dienų ir išsiunčiama pardavėjui (pašto ženklo data / antspaudas). Garantinio rašto B dalį galite rasti kiekvieno mechanizmo naudojimo ir priežiūros instrukcijos 2-uose paskutiniuose lapuose.
4. Mechanizmo garantija reiškia, jog pagaminimo defektai bus remontuojami ar pakeičiami nemokamai.
5. Pakeistos sugedusios dalys bus pripažintos kaip pakeistos nemokamai, tik tuo, kuomet gamintojas gauna ir patikrina sugedusias dalis apie tai pranešdamas oficialiu elektroniniu laišku. Darbo sąnaudos nėra laikomos garantija ir apmokestinamos papildomai.
6. Visi transportavimo kaštai priklauso pirkėjui ir nėra dengiami gamintojo garantijos.
7. Be autorizuoto tiesioginio RAIMONDI S.p.A. atstovo leidimo jokia garantinė sąlyga negali būti pakeista ar kitaip papildyta.

WARRANTY

During the 12-month warranty, RAIMONDI S.p.A. undertakes to supply, free of charge, those parts of its production found to be defective, in terms of material or processing. Such parts will have to be returned to RAIMONDI S.p.A., shipped carriage free. By warranty, we mean supply of defective parts, if any. The warranty does not cover all the expenses as to travel, board, lodging, transport and manpower concerning the replacement of parts by the RAIMONDI S.p.A. technicians, which will be charged entirely on the Customer. The warranty does not cover all the parts subject to wear. As to purchased components, the supplier warranty will apply. No compensation will be granted for expenses, damages or loss of profits incurred by customer. Installation of purchased parts not complying with the specifications of RAIMONDI S.p.A., if purchased or not supplied by RAIMONDI S.p.A., if manufactured by it, as well as improper use of the machine, will make the warranty null and void.

1. The machine warranty covers a 12-month period since the date of purchase.
2. The purchase date is the one indicated on the receipt for item purchased or invoice issued upon delivery of the machine by the retailer.
3. Any warranty becomes null and void if the B part is not entirely filled in and if sent later than 10 days after the date of purchase (postmark date).
4. By warranty we mean replacement or repair free of charge of components found to be defective since manufacturing.
5. Replacement of components, if made by the retailer, will be recognized free of charge once replaced components have been returned to our headquarters to be examined and declared as defective. Labor expenses are not included in the warranty.
6. All transport expenses will be charged on the purchaser.
7. The warranty does not cover parts subjected to wear, damage caused by negligence, improper use and installation and, in any case, issues not resulting from ordinary operation of the machine.
8. The warranty becomes null and void if the machine is tampered with or repaired by unauthorized personnel.
9. The warranty does not cover replacement of the machine and extension of the warranty following intervention for failure issues.
10. Nobody is entitled to modify the warranty conditions, nor to issue other warranties, in written or oral form, without the written authorization of RAIMONDI S.p.A.
11. The warranty does not cover compensation for damage, either direct or indirect, of any nature, to persons or objects, resulting from use or suspension of use of the machine.

RAIMONDI ON-LINE

APIE RAIMONDI.

Tai Italų kompanija, kuri oficialiai veiklą pradėjo nuo 1974 m, specializuojasi plytelių ir akmens apdirbimo/pjaustymo mechanizmuose ir įrankiuose. Tai yra ilgametis šeimos verslas, kuriame metai iš metų yra vadovaujamosi pagrindiniais trimis principais: kokybė, inovacijos, efektyvumas. Raimondi glaudžiai bendradarbiauja su plytelių gamintojais, seka naujausias madas šioje rinkoje ir visą laiką yra vienu žingsniu priekyje, kad pagelbėtų profesionaliam plytelių meistrai su naujausiais mechanizmais ir įrankiais.

Kodėl šunys? Raimondi logo esantys du šunys, kaip geriausi žmogaus draugai, simbolizuoja patikimumą ir ištikimybę.

RAIMONDI ON

Visus video apie Raimondi įrankius bei naujienas rasite Youtube kanale: "<http://www.youtube.lt/MPRODUCTS>"

ARBA skenuokite šį QR kodą ir žiūrėkite Raimondi video iš karto:



RAIMONDI DISTRIBUTORIUS.



www.mproducts.lt



www.viskasplytelems.lt



www.flisum.lv



www.rls.mproducts.lt



www.raimondi.lt

