



# sigma<sup>®</sup>

Made in Italy di Ambrogiani

Costruzione macchine   
per piastrellisti

Construction of machines   
for tilers

Construction de machines   
pour carreleurs

Herstellung von Maschinen   
Für Fliesenleger





**CATALOG - PRICE LIST**  
**valid from 15-09-2020**  
**to 14-09-2021**

	<ul style="list-style-type: none"> <li>🇮🇹 L'azienda</li> <li>🇬🇧 The company</li> <li>🇫🇷 La société</li> <li>🇩🇪 Das Unternehmen</li> </ul>	<b>pag. 6</b>
	<ul style="list-style-type: none"> <li>🇮🇹 Tagliapiastrelle SERIE 3 : Caratteristiche</li> <li>🇬🇧 Tile cutters SERIE 3 : Features</li> <li>🇫🇷 Coupe-carreaux SERIE 3: Caractéristiques</li> <li>🇩🇪 Fliesenschneider SERIE 3 : Eigenschaften</li> </ul>	<b>8</b>
37-95 cm.	<ul style="list-style-type: none"> <li>🇮🇹 Tagliapiastrelle SERIE 3 a trazione</li> <li>🇬🇧 Tile cutters SERIE 3 to pull</li> <li>🇫🇷 Coupe-carreaux SERIE 3 à tirer</li> <li>🇩🇪 Fliesenschneider SERIE 3 zu ziehen</li> </ul>	<b>10</b>
50.5-156 cm.	<ul style="list-style-type: none"> <li>🇮🇹 Tagliapiastrelle SERIE 3 Max</li> <li>🇬🇧 Tile cutters SERIE 3 Max</li> <li>🇫🇷 Coupe-carreaux SERIE 3 Max</li> <li>🇩🇪 Fliesenschneider SERIE 3 Max</li> </ul>	<b>14</b>
52-129 cm.	<ul style="list-style-type: none"> <li>🇮🇹 Tagliapiastrelle SERIE 3 Klick Klock</li> <li>🇬🇧 Tile cutters SERIE 3 Klick Klock</li> <li>🇫🇷 Coupe-carreaux SERIE 3 Klick Klock</li> <li>🇩🇪 Fliesenschneider SERIE 3 Klick Klock</li> </ul>	<b>18</b>
155-245 cm.	<ul style="list-style-type: none"> <li>🇮🇹 Tagliapiastrelle SERIE XL</li> <li>🇬🇧 Tile cutters SERIE XL</li> <li>🇫🇷 Coupe-carreaux SERIE XL</li> <li>🇩🇪 Fliesenschneider SERIE XL</li> </ul>	<b>22</b>
61-66 cm.	<ul style="list-style-type: none"> <li>🇮🇹 Tagliapiastrelle TECNICA</li> <li>🇬🇧 Tile cutters TECNICA</li> <li>🇫🇷 Coupe-carreaux TECNICA</li> <li>🇩🇪 Fliesenschneider TECNICA</li> </ul>	<b>24</b>
35-37 cm.	<ul style="list-style-type: none"> <li>🇮🇹 Tagliapiastrelle STANDARD</li> <li>🇬🇧 Tile cutters STANDARD</li> <li>🇫🇷 Coupe-carreaux STANDARD</li> <li>🇩🇪 Fliesenschneider STANDARD</li> </ul>	<b>26</b>
90-120 cm.	<ul style="list-style-type: none"> <li>🇮🇹 Macchine segatrici COMBIFLEX</li> <li>🇬🇧 Sawing machines COMBIFLEX</li> <li>🇫🇷 Machines à scier COMBIFLEX</li> <li>🇩🇪 COMBIFLEX Sägemaschinen</li> </ul>	<b>NEW 28</b>
151-382 cm.	<ul style="list-style-type: none"> <li>🇮🇹 Sistema di taglio KERA-CUT</li> <li>🇬🇧 Cutting system KERA-CUT</li> <li>🇫🇷 Système de coupe KERA-CUT</li> <li>🇩🇪 KERA-CUT Schneidsystem</li> </ul>	<b>30</b>

100-450 cm.	<ul style="list-style-type: none"> <li>🇮🇹 Banco di lavoro</li> <li>🇬🇧 Workbench</li> <li>🇫🇷 Table de travail</li> <li>🇩🇪 Werkbank</li> </ul>	<b>pag. 34</b>
100-340 cm.	<ul style="list-style-type: none"> <li>🇮🇹 Attrezzatura movimentazione KERA-LIFT</li> <li>🇬🇧 Handling tools KERA-LIFT</li> <li>🇫🇷 Appareil de manipulation KERA-LIFT</li> <li>🇩🇪 KERA-LIFT Hebe und Verlegerahmen</li> </ul>	<b>38</b>
	<ul style="list-style-type: none"> <li>🇮🇹 JOLLY EDGE per grandi smussi</li> <li>🇬🇧 JOLLY EDGE for big bevels</li> <li>🇫🇷 JOLLY EDGE pour grands chanfreins</li> <li>🇩🇪 JOLLY EDGE für breitflächige Kantenprofile</li> </ul>	<b>NEW 42</b>
	<ul style="list-style-type: none"> <li>🇮🇹 SIMPLE BEVEL per smussi precisi</li> <li>🇬🇧 SIMPLE BEVEL for accurate bevel</li> <li>🇫🇷 SIMPLE BEVEL pour biseaux de précision</li> <li>🇩🇪 SIMPLE BEVEL für präzisen Fasen</li> </ul>	<b>44</b>
100-300 mm.	<ul style="list-style-type: none"> <li>🇮🇹 Mole e dischi diamantati</li> <li>🇬🇧 Grinding wheels and diamond discs</li> <li>🇫🇷 Meules et disques de diamant</li> <li>🇩🇪 Schleifscheiben und Diamantscheiben</li> </ul>	<b>NEW 46</b>
6-70 mm.	<ul style="list-style-type: none"> <li>🇮🇹 Frese diamantate</li> <li>🇬🇧 Diamond drill bit</li> <li>🇫🇷 Fraises diamantées</li> <li>🇩🇪 Diamantfräser</li> </ul>	<b>NEW 50</b>
	<ul style="list-style-type: none"> <li>🇮🇹 Utensili per incollaggio</li> <li>🇬🇧 Gluing tools</li> <li>🇫🇷 Outils de collage</li> <li>🇩🇪 Klebwerkzeuge</li> </ul>	<b>52</b>
	<ul style="list-style-type: none"> <li>🇮🇹 Accessori</li> <li>🇬🇧 Accessories</li> <li>🇫🇷 Accessoires</li> <li>🇩🇪 Zubehör</li> </ul>	<b>NEW 54</b>
	<ul style="list-style-type: none"> <li>🇮🇹 Accessori</li> <li>🇬🇧 Accessories</li> <li>🇫🇷 Accessoires</li> <li>🇩🇪 Zubehör</li> </ul>	<b>56</b>
	<ul style="list-style-type: none"> <li>🇮🇹 Condizioni di vendita</li> <li>🇬🇧 Conditions of Sale</li> <li>🇫🇷 Conditions de vente</li> <li>🇩🇪 Bedingungen des Verkaufs</li> </ul>	<b>58</b>









-  Attrezzatura movimentazione KERA-LIFT
-  Handling tools KERA-LIFT
-  Appareil de manipulation KERA-LIFT
-  KERA-LIFT Hebe und Verlegerahmen

pag.

**38**







-  Kit carrello per KERA-LIFT
-  Carriage Kit for KERA-LIFT
-  Kit de Chariot pour KERA-LIFT
-  Wagen-Kit für KERA-LIFT







**40**



-  Banco di lavoro
-  Workbench
-  Table de travail
-  Werkbank

**34**







-  Frese diamantate
-  Diamond drill bit
-  Fraises diamantées
-  Diamantfräser

**NEW**

**50**





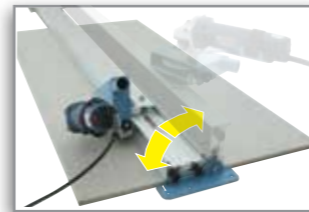

-  Sistema di taglio manuale KERA-CUT
-  Manual cutting system KERA-CUT
-  Système de coupe manuel KERA-CUT
-  Manuelles Schneidsystem KERA-CUT

pag.

**30**





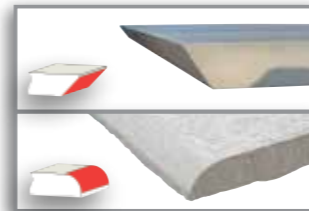

-  Sistema di taglio elettrico KERA-FLEX
-  Electric cutting system KERA-FLEX
-  Système de coupe électrique KERA-FLEX
-  Elektrisches Schneidsystem KERA-FLEX

**NEW**

**33**







-  JOLLY EDGE per jolly e toro
-  JOLLY EDGE for miter and bullnose
-  JOLLY EDGE pour grands chanfreins
-  JOLLY EDGE für Kantenprofile

**NEW**





**42**

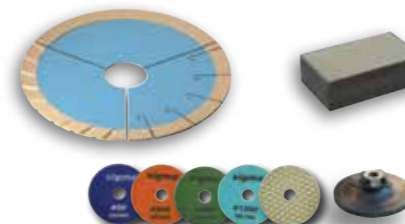

-  SIMPLE BEVEL per biselli precisi
-  SIMPLE BEVEL for accurate bevel
-  SIMPLE BEVEL pour biseaux de précision
-  SIMPLE BEVEL für präzise Fasen

**44**





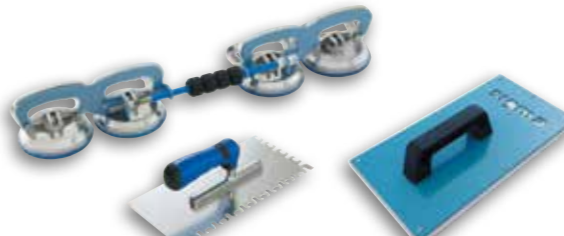

-  Mole e dischi diamantati
-  Grinding wheels and diamond discs
-  Meules et disques de diamant
-  Schleifscheiben und Diamantscheiben

**NEW**

**46**



-  Utensili per incollaggio
-  Gluing tools
-  Outils de collage
-  Klebwerkzeuge

**52**





1964 → 2021



La nostra azienda dal 1964 è specializzata nella produzione di attrezzi per piastrellisti, in base alle specifiche e mutevoli esigenze degli operatori professionali.

La realizzazione di prodotti di qualità, ne hanno determinato lo sviluppo costante nel corso degli anni sul mercato nazionale e su tutti i mercati internazionali.

La progettazione viene effettuata interamente dai nostri tecnici interni utilizzando programmi CAD 3D.

La produzione segue processi di lavorazione codificati, con collaudi in ogni fase del processo produttivo.

Le prove e i test effettuate prima sui prototipi poi sulle macchine in produzione consentono di garantire la realizzazione di un prodotto finito che risponda ad alti standard di qualità e robustezza, nel rispetto delle attuali normative europee.



Our company has been specializing since 1964 in the production of equipment for tilers, specifically designed to satisfy the changing needs of professionals.

Over the years the creation of quality products has promoted constant growth on all domestic and international markets.

All design work is carried out internally by our own technicians using 3D CAD programs.

Production is implemented with codified manufacturing processes, with checks at all stages of the process.

The checks and tests performed first on prototypes and then on standard production articles give a guarantee of finished products that satisfy the highest standards of safety and strength, in compliance with current European legislation.



Notre entreprise est spécialisée depuis 1964 dans la production d'outils pour carreleurs, réalisés en fonction des exigences spécifiques et variées des professionnels.

La réalisation de produits de qualité a favorisé le développement constant de notre entreprise qui, au cours des années, s'est affirmée sur le marché national et sur tous les marchés internationaux.

Nos produits sont entièrement conçus par nos propres techniciens, grâce à l'emploi de programmes CAD 3D.

La production suit des procédés de fabrication codifiés, prévoyant des essais lors de chaque phase de la réalisation.

Les essais et les tests effectués d'abord sur les prototypes puis sur les machines en production permettent de garantir la réalisation d'un produit fini qui répond à de hauts standards de qualité et de robustesse, conformément aux réglementations européennes en vigueur.



Unsere Firma wurde 1964 gegründet und hat sich in der Herstellung von Werkzeugen für Fliesenleger spezialisiert die den spezifischen und sich ständig entwickelnden Anforderungen von Profis nachkommen.

Die Herstellung hochwertiger Produkte hat dazu geführt dass sich die Firma im Laufe der Jahre im Inland sowie auf allen internationalen Märkten etablieren konnte.

Die Planung erfolgt dank unserer internen Techniker, hoch 3D CAD Programme und gänzlich in unserem Hause.

Die Produktion folgt kodifizierten Verarbeitungsabläufen wobei technische Kontrollen während des gesamten Produktionsablaufs durchgeführt werden.

Die Kontrollen und die Abnahmen die erst an den Prototypen und dann auch an den Maschinen selber durchgeführt werden, geben uns die Möglichkeit Ihnen Produkte mit einem hochqualitativen Standard zu bieten, die zudem auch robust sind und den gültigen europäischen Richtlinien nachkommen.





**Tagliapiastrelle SERIE 3 - caratteristiche**

**Tile Cutters SERIE 3 - features**

**Coupe Carreaux SERIE 3 - caractéristiques**

**Fliesenschneidemaschine Serie 3 Eigenschaften**



Sistema di cambio rapido dell'impugnatura di incisione  
Quick-change system of the incision handle



20mm  
15mm  
10mm  
8mm  
Guide cromate, molto robuste per una incisione perfettamente rettilinea  
Chromed guides, very robust for a perfectly straight incision



Ammortizzatore finecorsa per un lavoro silenzioso  
Shock-absorber for silent work



Predisposta per il taglio di piastrelle di basso spessore  
Predisposed for thin thickness tiles cutting



Guida ad altezza regolabile per incisione ergonomica di spessori diversi  
Driving height adjustable for ergonomic incision of different thicknesses



Impugnature ergonomiche con cuscinetti a sfere per incisione veloce a trazione o a spinta  
Ergonomic handles with ball bearings for fast pull or push incision



Piani standard, facilmente sostituibili con il KIT per il taglio di mosaico (3G-3L)  
Standard plate, can be easily replaced with the kit for cutting mosaic (3G-3L)

6/7 piedi in gomma morbida antiscivolo, di grande diametro

6/7 support feet in soft anti-slip rubber, large diameter

La struttura in alluminio, più è lunga, più è robusta

Aluminum structure, stronger in proportion to length

Supporti molleggiati, apribili per il sostegno di grandi piastrelle

Openable spring arms, for support of large tiles

Ingombro ridotto per il trasporto

Reduced volume for transport

Barra metrica con angolazione e misurazione, sempre vicina all'operatore

Metric bar with angle and measurement, always close to operator

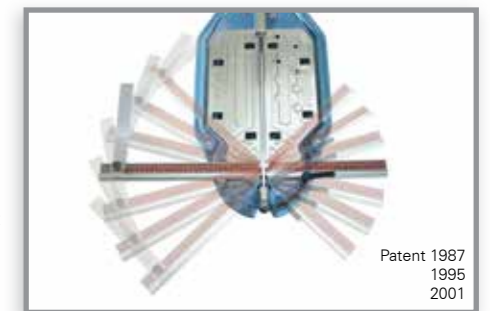

Barra metrica fulcrata in centro alla linea di taglio, orientabile +45° 0° - 45°

Measurement bar pivoted at the centre of the cutting line; swivelling +45° 0° - 45°



Tasto regolabile, per il posizionamento rapido della barra metrica alle angolazioni più usate

Adjustable stop for quick positioning of metric bar to the angles most commonly used

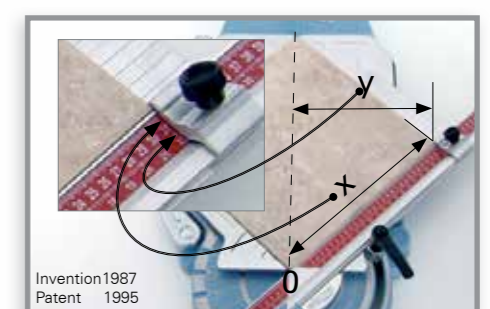

Righetta metrica con misura del lato e della diagonale

Metric scale with side measure and diagonal measure

Lungo squadra di appoggio posizionabile a destra e sinistra

Long measuring square for use on right or left

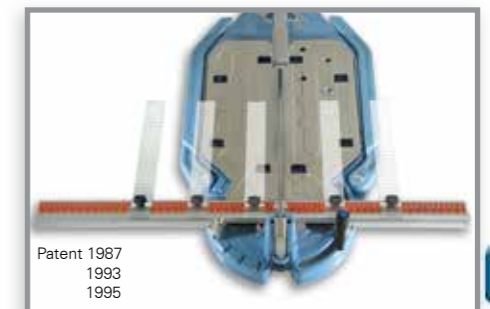
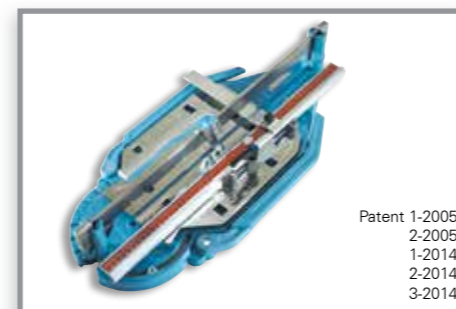
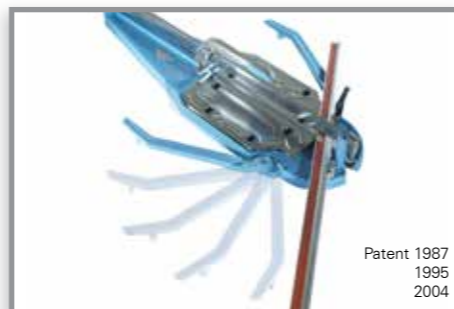
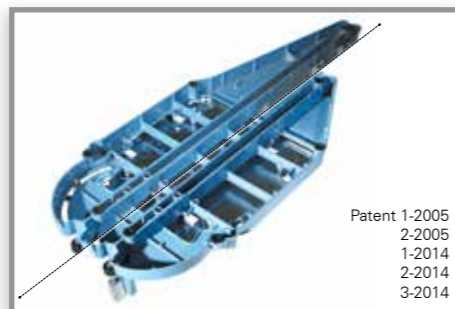



🇮🇹 Tagliapiastrelle

🇫🇷 Coupe Carreaux

🇬🇧 Tile Cutters

🇩🇪 Fliesenschneider

SERIE 3

**sigma**  
di Ambrogiani

🇮🇹 Incisione a trazione, pratica e veloce

🇬🇧 Pulling incision, fast and practical

🇫🇷 Incision à tirer, rapide et pratique

🇩🇪 Praktisches und schnelles Ritzen durch Ziehen

international patents

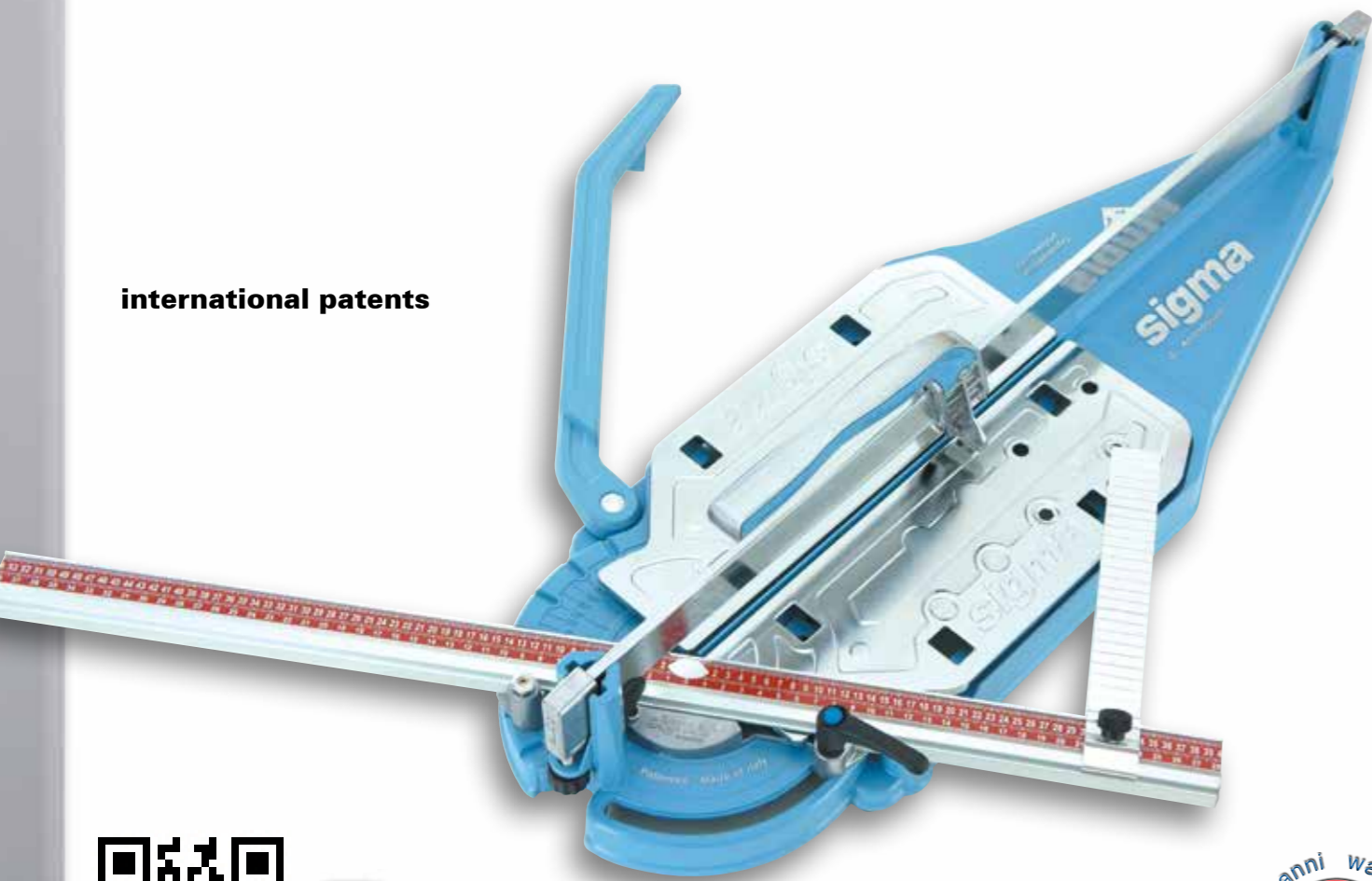

sigmaitalia



Art.									
2G	37 cm 14,6 inc	26 cm 10,2 inc	3-15mm 9/16inc	600 Kg.	2,6 Kg.	6 pz. 17,3 Kg.	54 x 43 x 32 cm.	120 pz.	
3L	55 cm 21,7 inc	38 cm 15,0 inc	0-19mm 3/4 inc	1050 Kg.	7,9 Kg.	2 pz. 17,2 Kg.	78 x 42 x 30 cm.	36 pz.	
3B4	67 cm 26,4 inc	47 cm 18,5 inc	0-19mm 3/4 inc	1050 Kg.	10,0 Kg.	2 pz. 22,0 Kg.	92 x 41 x 31 cm.	36 pz.	
3C2	77 cm 30,3 inc	54 cm 21,3 inc	0-19mm 3/4 inc	1050 Kg.	11,5 Kg.	1 pz. 13,0 Kg.	104 x 41 x 24 cm.	16 pz.	
3D4	95 cm 37,4 inc	67 cm 26,4 inc	0-19mm 3/4 inc	1050 Kg.	13,1 Kg.	1 pz. 14,8 Kg.	123 x 42 x 23 cm.	16 pz.	

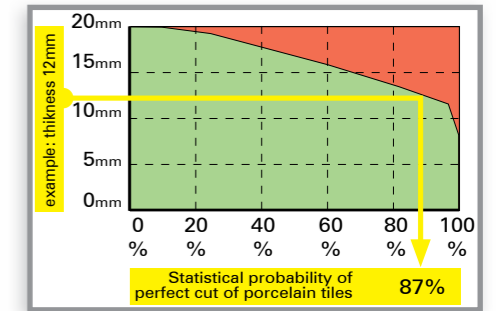
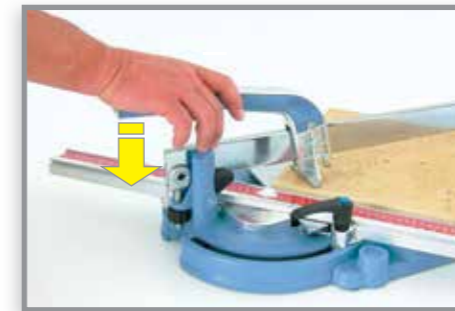
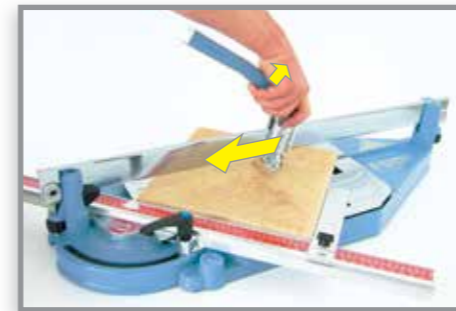

- 🇮🇹 Incisione
- 🇬🇧 Incision
- 🇫🇷 Incision
- 🇩🇪 Ritzen

- 🇮🇹 Spacco
- 🇬🇧 Breaking
- 🇫🇷 Sectionnement
- 🇩🇪 Brechen

- 🇮🇹 Probabilità statistica di taglio perfetto su piastrelle in gres porcellanato
- 🇬🇧 Statistical probability of perfect cut of porcelain tiles
- 🇫🇷 Probabilité statistique de coupe parfaite des carreaux en grès cérame
- 🇩🇪 Statistische Wahrscheinlichkeit von perfekten Schnitten an Feinsteinzeugfliesen

Piede di spacco largo 70mm, ottimale per il taglio veloce di tutti i tipi di piastrelle

Gap foot wide 70 mm, ideal for fast cutting of all types of tiles

L'impugnatura scorre sulla guida appoggiandosi su un cuscinetto a sfere

The handle slides on the guide leaning on a ball bearing

La rotella è disponibile anche nelle versioni: rivestita TIN e per mosaico vetroso

The wheel is also available in the following versions: TIN coated and Glass Mosaic

Protezione antisegno intercambiabile

Protection to prevent marks interchangeable

Impugnatura ergonomica, ottimizzata per incisione a trazione  
Ergonomic handle, optimized for pulling incision

Le superfici di scorrimento di guida e rotella, sono lavorate con macchina utensile, per una incisione perfettamente rettilinea nel tempo.

Sliding surface of the wheel and guide bar, are internally worked with the tool machine, for a perfect straight incision in the time.

L'impugnatura è dotata di un sistema per il recupero dell'usura da scorrimento sulla guida

The handle is equipped with a system for recovery of wear from sliding on the guide

La rotella è dotata di sistema di recupero del gioco laterale

The wheel is equipped with a recovery system of side clearance



Piede di spacco in lega di alluminio, leggero ma rigido, per uno spacco efficace

Gap foot of aluminum alloy, light but rigid, for an effective split



**Incisione veloce a trazione**

**Fast pulling incision**

**Incision rapide à tirer**

**Schnelles Ritzen durch Ziehen**

**SERIE 3**



**Art. 2G cm.37**

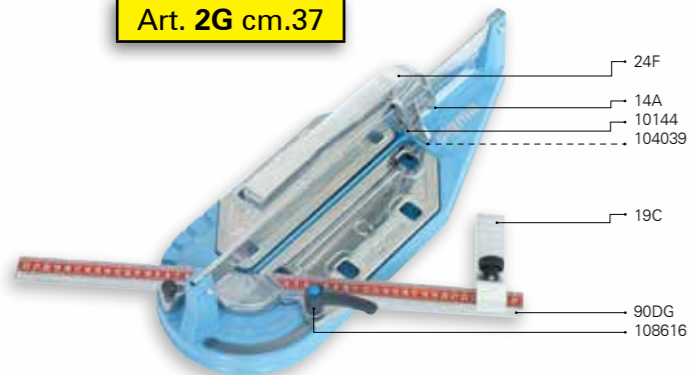

**Art. 64B KIT mosaico**



**Art. 3L cm.55**

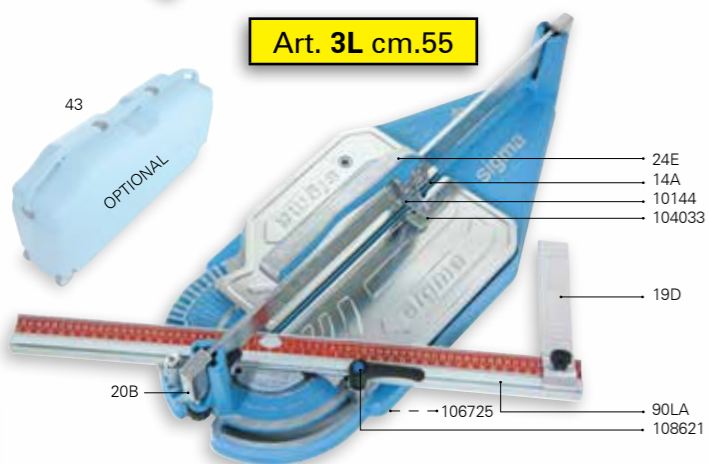

**Art. 3B4 cm.67**

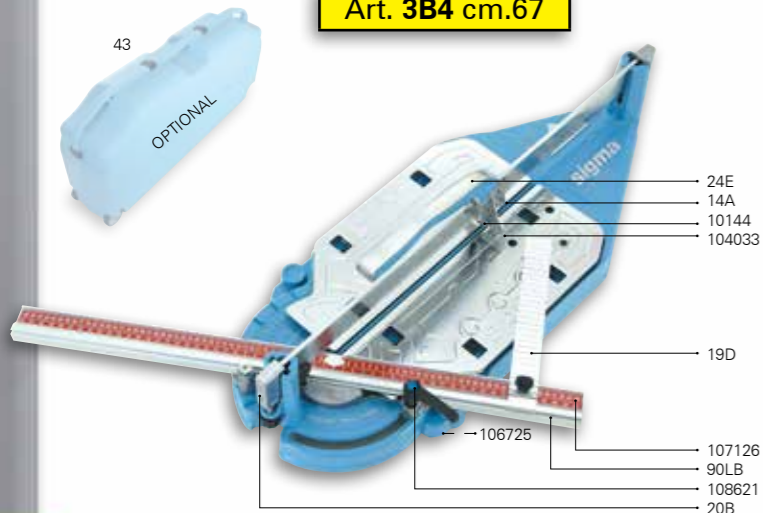

**Art. 3C2 cm.77**

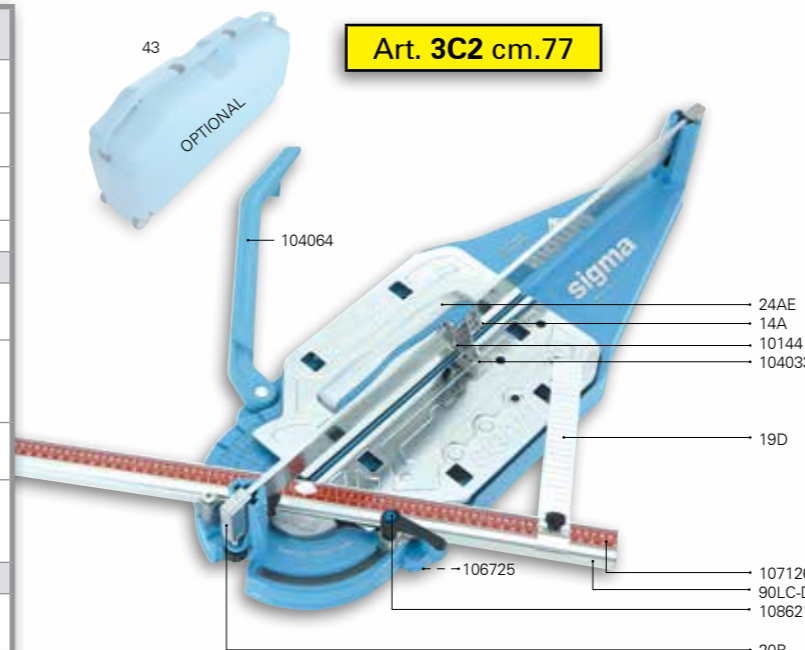

**Art. 3D4 cm.95**

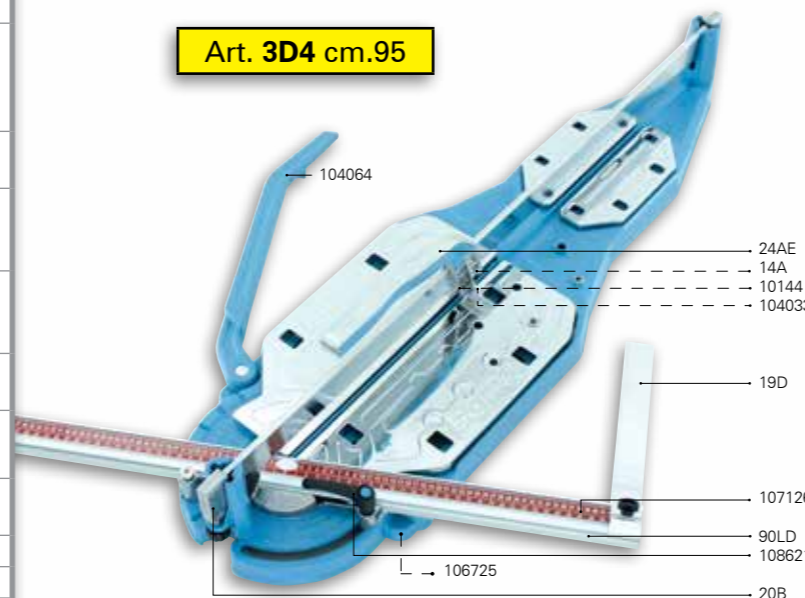

Art.	Descrizione	Description	
2G	TAGLIA PIASTRELLE cm.37	TILE CUTTER cm.37	6
3L	TAGLIA PIASTRELLE cm.55	TILE CUTTER cm.55	2
3B4	TAGLIA PIASTRELLE cm.67	TILE CUTTER cm.67	2
Tile cutters may be available with the inch measurement bar			
Accessori a richiesta		Accessoires on request	
64B	KIT Mosaico per Art. 3G-3L. completo di art. 14M	Mosaic KIT for Art 3G-3L. complete with art. 14M	1
43	Valigia con ruote per Art. 3G-3L-3B. Dimensioni 1030 x 500 x 227mm	Suitcase with wheels for Art. 3G-3L-3B. Dimensions 1030x500x227mm	1
14T	Rotella per incisione al TITANIO, Ø mm 12 completa	Ø 12 mm complete TITANIUM scoring wheel	20
14M	Rotella per incisione mosaico vetroso Ø mm 12 completa	Ø12 mm complete scoring wheel for glass mosaic	20
Ricambi		Spare parts	
14A	Rotella per incisione Ø mm 12 completa	Ø 12 mm complete scoring wheel	20
24F	Impugnatura a trazione scavo 6, con protezioni antisegno, completa di Art.14A per Art.2G	Pulling handle 6 mm groove, with Art.14A, NO-MARK protection, for Art. 2G	1
24E	Impugnatura ERGONOMICA a trazione scavo 8, con protezioni antisegno, completa di Art.14A per Art. 3L-3B4	ERGONOMIC pulling handle 8 mm groove, with Art.14A, NO-MARK protection, for Art. 3L-3B4	1
104039	Protezione sottopiede antisegno per leva Art. 24F.	NO-MARK protection for pulling handle Art.24F	1
104033	Protezione sottopiede antisegno per leva Art. 24E-24K.	NO-MARK protection for pulling handle Art. 24E-24K.	1
10144	Cuscinetto a sfere rinforzato 16/5/5 per leva Art. 24E-24F	Reinforced ball bearing 16/5/5 for Art. 24E-24F	1
90DG	Barra metrica orientabile per Art.2G.	Swivel measurement bar for Art. 2G.	1
90LA	Barra metrica orientabile per Art. 3L 41-0-33cm.	Swivel measurement bar for Art. 3L. 41-0-33cm.	1
90LB	Barra orientabile per Art. 3B4 47-0-35cm.	Swivel measurement bar for Art. 3B4 47-0-35cm.	1
19C	Squadretta per art. 2G.	Square for art. 2G.	1
19D	Squadretta per art. 3	Square for art. 3	1
107126	Righetta metrica adesiva per art. 3/ABCDEFGLP.	Adhesive measurement tape for art. 3/ABCDEFGLP.	1
108616	Pomolo a leva M8x25 per art. 2G.	Clamping knob lever M8x25 for art. 2G.	1
108621	Pomolo a leva M8x40 per art. 3L-3B4.	Clamping knob lever M8x40 for art. 3L-3B4.	1
1079104	Dado M8 Esagono 20 per Pomolo a leva	Nut M8 Hex 20 for Clamping knob lever	1
20B	Bilico scavo 15 completo per art.3L-3B4-3C2-3D4	Complete adjustable support screw 15 for art.3L-3B4-3C2-3D4	1
106725	Tappo piede 20/25 H24 per Art. 3L-3B4-3C2-3D4	Rubber foot 20/25 H24 for Art. 3L-3B4-3C2-3D4	1
106731	Tappo piede 13/17 H16 per Art. 2G.	Rubber foot 13/17 H16 for Art. 2G.	1

Vendita a confezioni intere Sold in full packs only

Art.	Descrizione	Description	
3C2	TAGLIA PIASTRELLE cm.77	TILE CUTTER cm.77	1
3D4	TAGLIA PIASTRELLE cm.95	TILE CUTTER cm.95	1
Tile cutters may be available with the inch measurement bar			
Accessori a richiesta		Accessoires on request	
90E4	Misura anteriore da 30 a 400mm per art 3L-3B4-3C2-3D2-3D4 (taglio utile= max - 5cm.)	Front measure from 30 to 400mm for art 3L-3B4-3C2-3D2-3D4 (working cut = max - 5cm.)	1
43	Valigia con ruote per Art. 3C2	Suitcase with wheels for 3C2	1
43D1	Valigia in tela imbottita con ruote per Art. 3D2-3D4	Canvas padded case with wheels for Art. 3D2-3D4	2
104064	Supporto Sx completo	Complete Left support	1
104065	Supporto Dx completo	Complete Right support	1
14T	Rotella per incisione al TITANIO, Ø mm 12 completa	Ø 12 mm complete TITANIUM scoring wheel,	20
Ricambi		Spare parts	
14A	Rotella per incisione Ø mm 12 completa	Ø 12 mm complete scoring wheel	20
24AE	Impugnatura ERGONOMICA a trazione scavo 10, con protezioni antisegno, completa di Art.14A per Art.3C2-3D2-3D4	ERGONOMIC pulling handle 10 mm groove, with Art.14A, NO-MARK protection, for Art.3C2-3D2-3D4	1
104033	Protezione sottopiede antisegno per leva Art. 24E-24AE.	NO-MARK protection for pulling handle Art. 24E-24AE.	1
10144	Cuscinetto a sfere rinforzato 16/5/5 per leva Art. 24E-24AE	Reinforced ball bearing 16/5/5 for Art. 24E-24AE	1
19D	Squadretta lunga 260 mm	Square 260 mm long	1
107126	Righetta metrica adesiva per art. 3/ABCDEFGLP.	Adhesive measurement tape for art. 3/ABCDEFGLP.	1
90LC	Barra metrica orientabile per Art. 3C2 54-0-40cm.	Swivel measurement bar for Art. 3C2 54-0-40cm.	1
90LD	Barra metrica orientabile per Art. 3D2-3D4 64-0-46cm.	Swivel measurement bar for Art. 3D2-3D4 64-0-46cm.	1
108621	Pomolo a leva M8x40 per art. 3B4-3C2-3D4	Clamping knob lever M8x40	1
1079104	Dado M8 Esagono 20 per Pomolo a leva	Nut M8 Hex 20 for Clamping knob lever	1

Vendita a confezioni intere Sold in full packs only



**Art. 43**

Valigia con ruote per: Suitcase with wheels for: Art. 3L-3B4-3C2

**Art. 43D1**

Valigia tela imbottita con ruote per: Art. 3D2-3D4 Canvas padded case with wheels for: Art.3D2-3D4

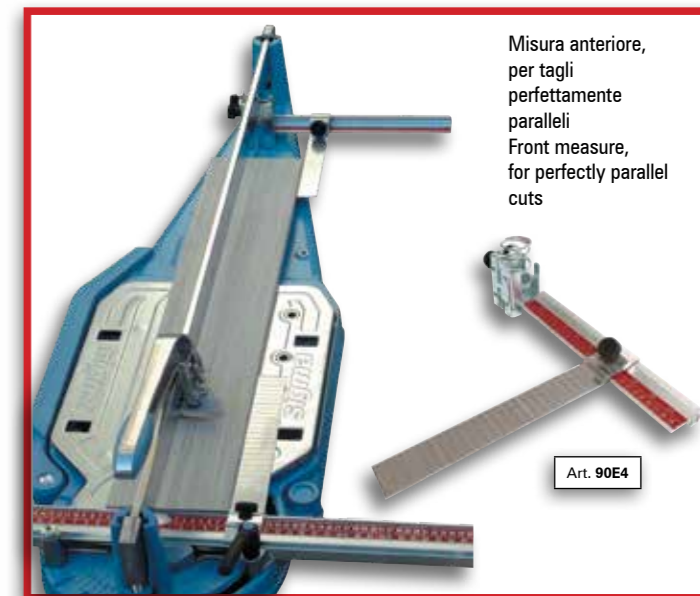

Misura anteriore, per tagli perfettamente paralleli Front measure, for perfectly parallel cuts

**Art. 90E4**





🇮🇹 Tagliapiastrelle

🇫🇷 Coupe Carreaux

🇬🇧 Tile Cutters

🇩🇪 Fliesenschneider

# SERIE 3 MAX



🇮🇹 **Incisione a spinta , facile e profonda**

🇬🇧 **Pushing incision, easy and deep**

🇫🇷 **Incision à pousser, facile et profonde**

🇩🇪 **Das einfaches und tiefe Ritzen erfolgt durch Schieben**

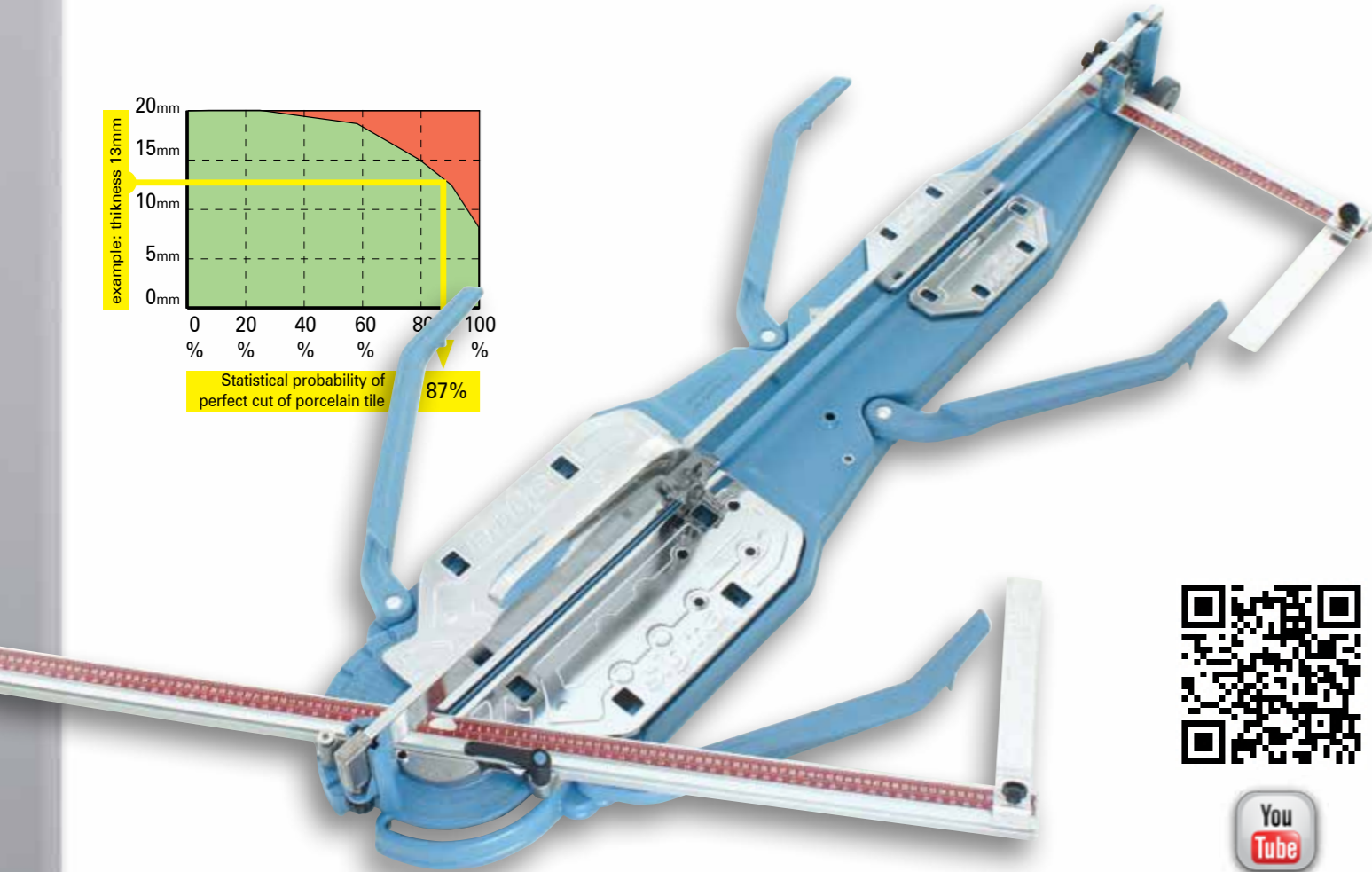
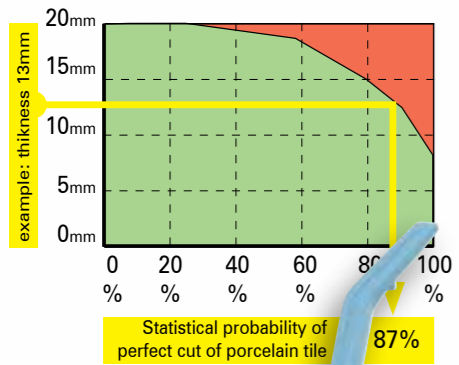

sigmaitalia

international patents

Art.									
3L3M	50,5 cm 19,9 inc	35,7 cm 14,0 inc	0-19 mm 3/4 inc	1200 Kg.	7,7 Kg.	2 pz. 16,9 Kg.	78 x 42 x 30 cm	36 pz.	
3B4M	62,5 cm 24,6 inc	44,1 cm 17,3 inc	0-19 mm 3/4 inc	1200 Kg.	10,4 Kg.	2 pz. 22,4 Kg.	92 x 41 x 31 cm	36 pz.	
3C3M	72,5 cm 28,5 inc	51,3 cm 20,2 inc	0-19 mm 3/4 inc	1200 Kg.	11,7 Kg.	1 pz. 13,2 Kg.	104 x 41 x 24cm	16 pz.	
3D4M	90,5 cm 35,6 inc	64,0 cm 25,2 inc	0-19 mm 3/4 inc	1200 Kg.	13,4 Kg.	1 pz. 15,1 Kg.	123 x 42 x 23cm	16 pz.	
3P3M	100,5 cm 39,6 inc	71,0 cm 27,9 inc	0-19 mm 3/4 inc	1200 Kg.	17,1 Kg.	1 pz. 18,5 Kg.	137 x 46 x 20cm	16 pz.	
3E4M	127,4 cm 50,1 inc	90,0 cm 35,4 inc	0-19 mm 3/4 inc	1200 Kg.	21,1 Kg.	1 pz. 22,7 Kg.	164 x 46 x 20cm	10 pz.	
3F4M	156,0 cm 61,4 inc	110,3 cm 43,4 inc	0-19 mm 3/4 inc	1200 Kg.	34,9 Kg.	1 pz. 36,5 Kg.	193 x 46 x 20cm	10 pz.	



- 🇮🇹 Incisione
- 🇬🇧 Incision
- 🇫🇷 Incision
- 🇩🇪 Ritzen



- 🇮🇹 Rotazione piede di rottura
- 🇬🇧 Rotate splitting foot
- 🇫🇷 Tournez pied de coupure
- 🇩🇪 Drehung Brechvorrichtung



- 🇮🇹 Spacco
- 🇬🇧 Breaking
- 🇫🇷 Sectionnement
- 🇩🇪 Brechen

Doppio molleggio per una incisione ammortizzata, indispensabile per la lavorazione di piastrelle rugose o con superficie strutturata

Double springing for an cushioned incision, which is essential for the working of tiles with rough or textured surface

Protezione antisegno intercambiabile

Protection to prevent marks interchangeable

Piede di spacco molto largo, 100mm, ottimale per il taglio facile di grandi piastrelle

Foot gap very wide, 100mm, perfect for easy cutting large tiles

Piede di spacco in lega di alluminio, leggero ma rigido, per uno spacco efficace

Gap foot of aluminum alloy, light but rigid, for a effective split



Impugnatura ergonomica, ottimizzata per incisione a spinta

Ergonomic handle, optimized for pushing cutting

Le superfici di scorrimento di guida e rotella, sono lavorate con macchina utensile, per una incisione perfettamente rettilinea nel tempo.

Sliding surface of the wheel and guide bar, are working with the tool machine, for a perfectly straight incision over the time.

L' impugnatura scorre sulla guida appoggiandosi su un cuscinetto a sfere

The grip slides on the guide leaning on a ball bearing

Rotella di incisione di grande diametro, per una facile incisione su piastrelle strutturate

Incision wheel of large diameter, for easy engraving on structured tiles

La rotella ruota su un cuscinetto a sfere stagno, per una incisione facile e veloce

The wheel rotates on a pond ball bearing, for a fluently and quickly incision

La rotella è dotata di sistema di recupero del gioco laterale

The wheel is equipped with a recovery system of side clearance



**Incisione a spinta**

**Pushing incision**

**Incision à pousser**

**Incision zu drücken**

# SERIE 3 MAX

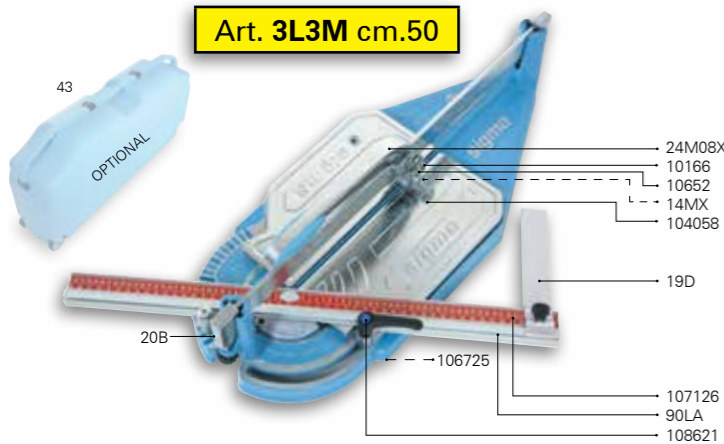

**Art. 3L3M cm.50**

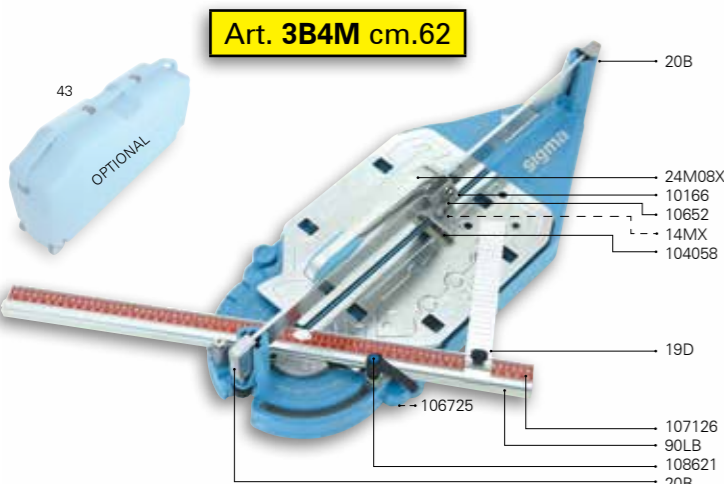

**Art. 3B4M cm.62**

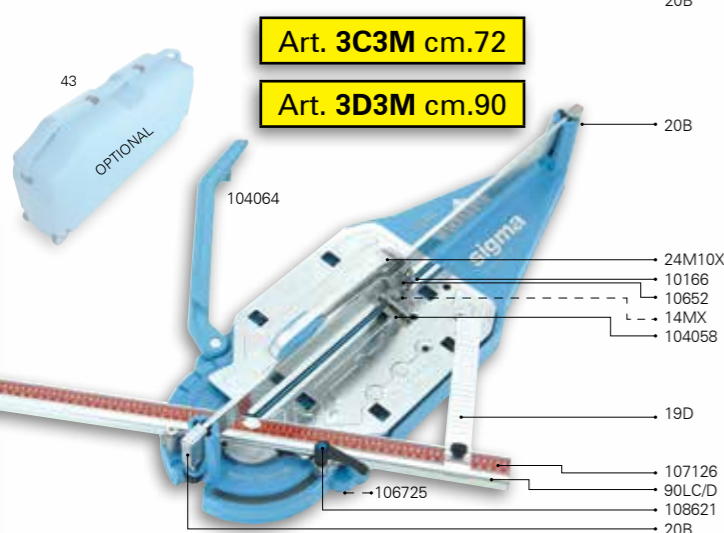

**Art. 3C3M cm.72**

**Art. 3D3M cm.90**



Valigia tela imbottita con ruote per:  
Canvas padded case with wheels for:

Art. 3D4M 3E4M

Art. 43D1 Art. 43E1

Art.	Descrizione	Description	
3L3M	TAGLIA PIASTRELLE cm.50	TILE CUTTER cm.50	2
3B4M	TAGLIA PIASTRELLE cm.62	TILE CUTTER cm.62	2
3C3M	TAGLIA PIASTRELLE cm.72	TILE CUTTER cm.72	1
Tile cutters may be available with the inch measurement bar			
Accessori a richiesta		Accessoires on request	
43	Valigia con ruote per Art. -3L3M-3B4M- 3C3M Dimensioni 1030 x 500 x 227mm.	Suitcase with wheels for Art. 3L3M-3B4M-3C3M Dimensions 1030 x 500x227mm	1
104064	Supporto Sx completo.	Complete Left support.	1
104065	Supporto Dx completo.	Complete Right support.	1
Ricambi		Spare parts	
14MX	Rotella per incisione Ø 19 mm completa.	Ø 19 mm complete scoring wheel	20
24M08X	Impugnatura MAX a spinta scavo 8 mm, con protezioni antisegno, completa di Art.14MX per Art. 3A3M-3L3M-3B4M.	MAX pushing handle 8 mm groove, with Art.14MX, NO-MARK protection, for Art. 3A3M-3L3M-3B4M.	1
24M10X	Impugnatura MAX a spinta scavo 10 mm, con protezioni antisegno, completa di Art.14MX per Art.3C3M	MAX pushing handle 10 mm groove, with Art.14MX, NO-MARK protection,for Art.3C3M	1
104058	Protezione sottopiede antisegno per leva Art. 24M08X-24M10X	NO-MARK protection for pushing handle Art.24M08X-24M10X	1
10166	Cuscinetto a sfere rinforzato 16/5/5 per leva Art. 24M*	Reinforced ball bearing 16/5/5 for Art. 24M*	1
10652	Molla occhielli per imp.MAX.	Spring for MAX handle.	1
19D	Squadretta lunga 260 mm.	Square 260 mm. long	1
90LA	Barra metrica orientabile per Art. 3L3M. 41-0-33cm.	Swivel measurement bar for Art. 3L3M.	1
90LB	Barra metrica orientabile per Art.3B4M. 47-0-35cm.	Swivel measurement bar for Art.3B4M.	1
90LC	Barra metrica orientabile per Art. 3C3M. 54-0-40cm.	Swivel measurement bar for Art.3C3M.	1
107126	Righetta metrica adesiva per art. 3/ABCDEFGLP.	Adhesive measurement tape for art. 3/ABCDEFGLP.	1
108621	Pomolo a leva M8x40 per art. 3	Clamping knob lever M8x40 for art. 3	1
1079104	Dado M8 Esagono 20 per Pomolo a leva.	Nut M8 Hex 20 for Clamping knob lever.	1
20B	Bilico scavo 15 completo per art.3/ABCDGL/M.	Complete adjustable support screw 15 for art.3	1
106725	Tappo piede 20/25 H24 per Art. 3/ABCDGL/M.	Rubber foot 20/25 H24 for Art. 3/ABCDGL/M.	1

Vendita a confezioni intere Sold in full packs only

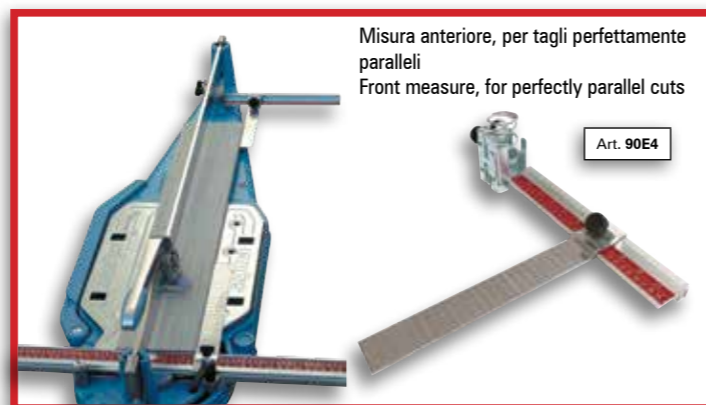

Misura anteriore, per tagli perfettamente paralleli  
Front measure, for perfectly parallel cuts

Art. 90E4

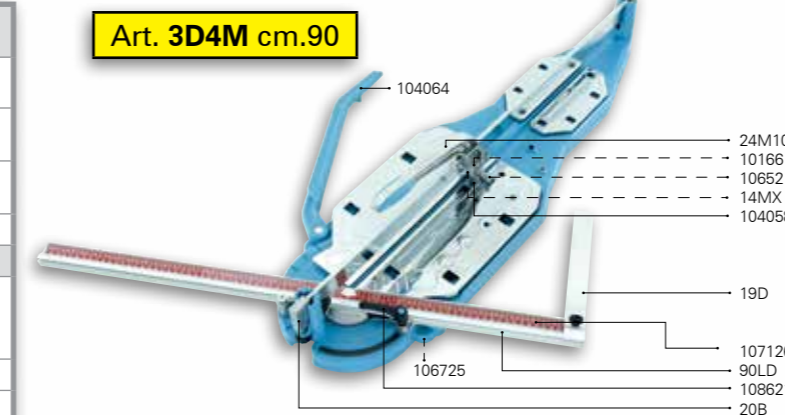

**Art. 3D4M cm.90**

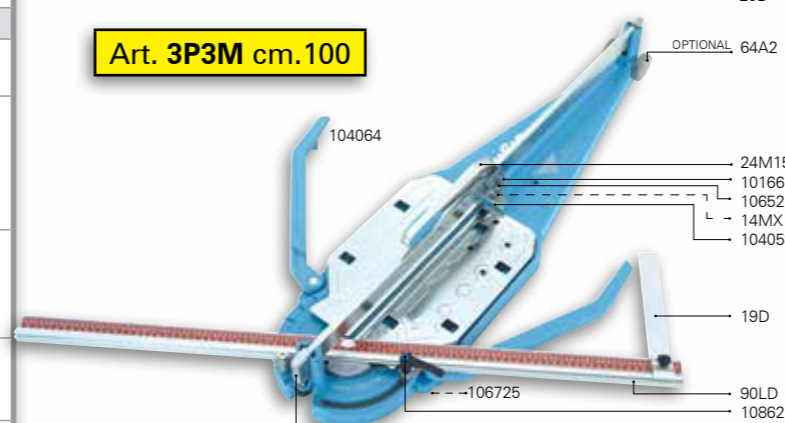

**Art. 3P3M cm.100**

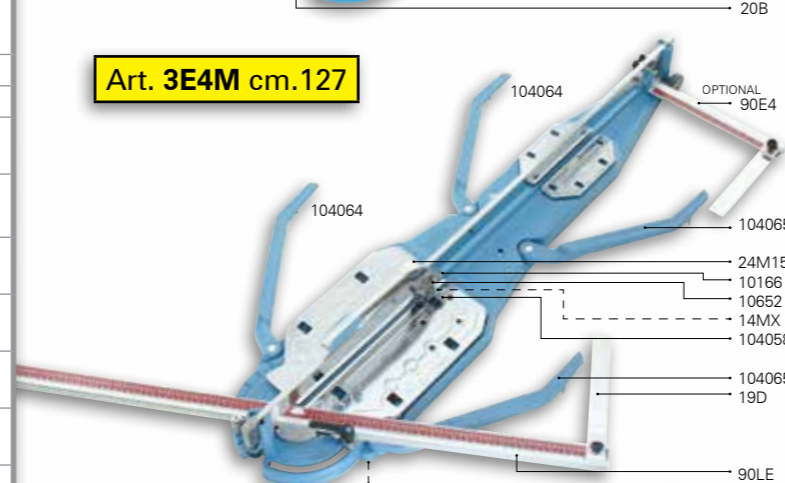

**Art. 3E4M cm.127**

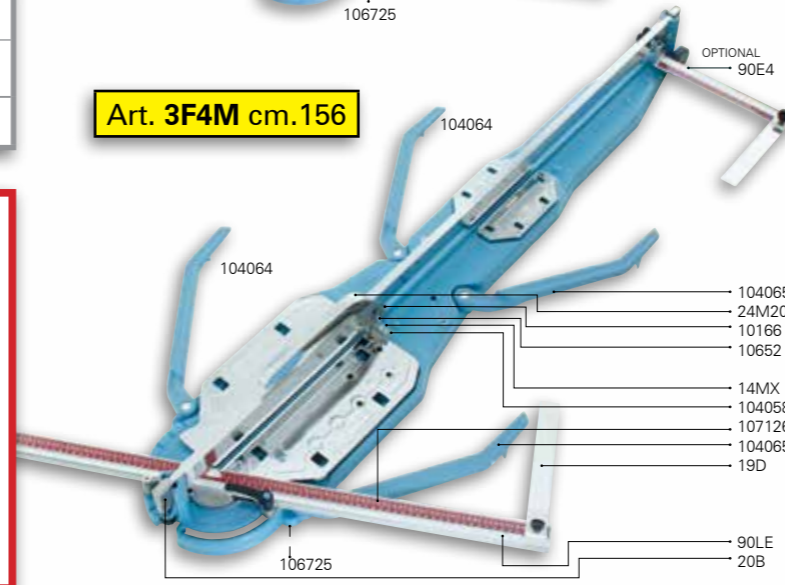

**Art. 3F4M cm.156**

Art.	Descrizione	Description	
3D4M	TAGLIA PIASTRELLE cm.90	TILE CUTTER cm.90	1
3P3M	TAGLIA PIASTRELLE cm.100	TILE CUTTER cm.100	1
3E4M	TAGLIA PIASTRELLE cm.127	TILE CUTTER cm.127	1
3F4M	TAGLIA PIASTRELLE cm.156	TILE CUTTER cm.156	1
Tile cutters may be available with the inch measurement bar			
Accessori a richiesta		Accessoires on request	
43D1	Valigia in tela imbottita con ruote per Art. 3D3M-3D4M	Canvas padded case with wheels for Art. 3D3M-3D4M	2
43E1	Valigia in tela imbottita con ruote per Art. 3E4M	Canvas padded case with wheels for Art. 3E4M	2
90E4	Misura anteriore da 30 a 400mm per art. 3G3M-3L3M-3B4M-3C3M-3D4M-3P3M-3E4M-3F4M (taglio utile = max - 5cm.)	Front measure from 30 to 400mm per art. 3G3M-3L3M-3B4M-3C3M-3D4M-3P3M-3E4M-3F4M (working cut = max - 5cm.)	1
104064	Supporto Sx completo per art. 3/ABCDGL/M.	Complete Left support for art. 3/ABCDGL/M.	1
104065	Supporto Dx completo per art. 3/ABCDGL/M.	Complete Right support for art. 3/ABCDGL/M.	1
64A2	Gruppo ruote per 3P3M	wheel unit for 3P3M	1
Ricambi		Spare parts	
14MX	Rotella per incisione Ø 19 mm	Ø 19 mm scoring wheel ,	20
24M10X	Impugnatura MAX a spinta scavo 10 mm, con protezioni antisegno, completa di Art.14MX per Art.3D4M.	MAX pushing handle 10 mm groove, with Art.14MX, NO-MARK protection,for Art. 3D4M.	1
24M15X	Impugnatura MAX a spinta scavo 15 mm, con protezioni antisegno, completa di Art.14MX per Art. 3P3M 3E4M	MAX pushing handle 15 mm groove,with Art.14MX, NO-MARK protection, for Art.3P3M-3E4M	1
24M20X	Impugnatura MAX a spinta scavo 20 mm, con protezioni antisegno, completa di Art.14MX per Art.3F4M.	MAX pushing handle 20 mm groove,with Art.14MX, NO-MARK protection,for Art.3F4M.	1
104058	Protezione sottopiede antisegno per leva Art. 24M10X-24M15X-24M20X	NO-MARK protection for pushing handle Art.24M10X-24M15X-24M20X	1
10166	Cuscinetto a sfere rinforzato 16/5/5 per leva Art. 24M*	Reinforced ball bearing 16/5/5 for leva Art. 24M*	1
10652	Molla occhielli per imp.MAX.	Spring for MAX pushing handle	1
19D	Squadretta 260mm per art.3/ABCDEF/M.	260mm Square for art.3/ABCDEF/M.	1
90LD	Barra metrica orientabile per Art. 3D4M-3P3M. 64-0-46cm	Swivel measurement bar for Art.3D4M-3P3M.	1
90LE	Barra metrica orientabile per Art. 3E4M-3F4M. 64-0-64cm.	Swivel measurement bar for Art.3E4M-3F4M.	1
107126	Righetta metrica adesiva per art. 3/ABCDEFGLP.	Adhesive measurement tape for art.3/ABCDEFGLP.	1
108621	Pomolo a leva M8x40 per Art. 3/ABCDEFGL/M.	Clamping knob lever M8x40 for Art. 3/ABCDEFGL/M.	1
1079104	Dado M8 Esagono 20 per Pomolo a leva.	Nut M8 Hex 20 for Clamping knob lever.	1
20B	Bilico scavo 15 completo per Art. 3/ABCDEFGL/M.	Complete adjustable support screw 15 for 3/ABCDEFGL/M.	1
106725	Tappo piede 20/25 H24 per Art. 3/ABCDGL/M.	Rubber foot 20/25 H24 for Art. 3/ABCDGL/M.	1

Vendita a confezioni intere Sold in full packs only



Tagliapiastrelle

Coupe Carreaux

Tile Cutters

Fliesenschneider

# SERIE 3 KLICK KLOCK



Incisione a spinta , facile e profonda

Pushing incision , easy and deep

Incision à pousser , facile et profonde

Das einfaches und tiefe Ritzen erfolgt durch Schieben

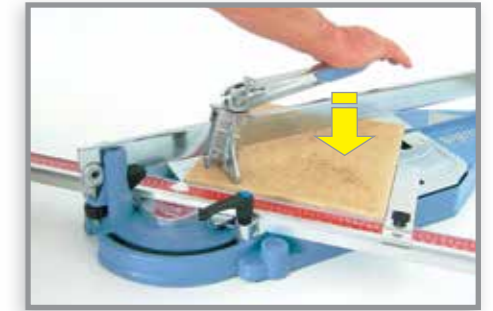
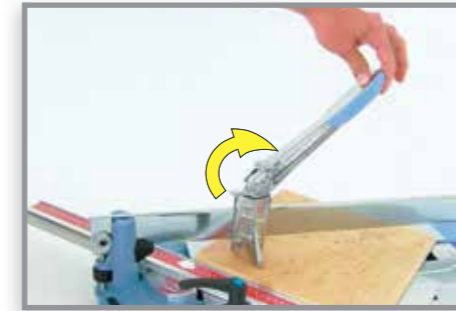
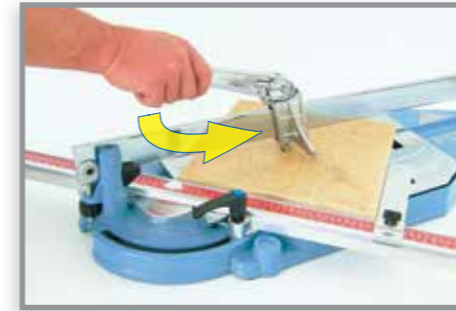
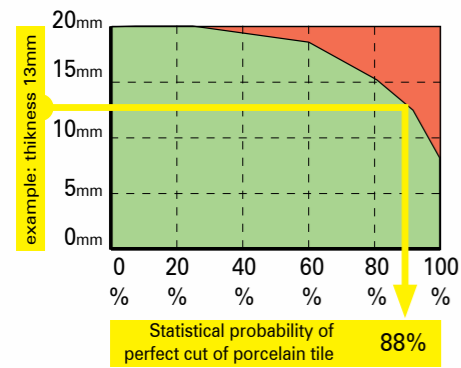

- Incisione
- Incision
- Incision
- Ritzen

- Rotazione piede di rottura
- Rotate splitting foot
- Tournez pied de coupure
- Drehung Brechvorrichtung

- Spacco
- Breaking
- Sectionnement
- Brechen

Piede di spacco molto largo, 100mm, ottimale per il taglio facile di grandi piastrelle

Wide foot gap, 100mm, perfect for cutting easily large tiles

La rotella è dotata di sistema di recupero del gioco laterale

The wheel is equipped with a recovery system of side clearance

Sistema di molleggio per una incisione ammortizzata, indispensabile per la lavorazione di piastrelle rugose o con superficie strutturata

Spring system for a cushioned incision, indispensable for the working of tiles with rough or textured surface

La rotella è disponibile anche nella versione rivestita TIN

The wheel is also available TIN coated

Impugnatura ergonomica, ottimizzata per incisione a spinta

Ergonomic handle, optimized for pushing cutting

Le superfici di scorrimento di guida e rotella, sono lavorate con macchina utensile, per una incisione perfettamente rettilinea nel tempo.

Sliding surface of the wheel and guide bar, are working with the tool machine, for a perfectly straight incision over the time.

Il sistema KLICK KLOCK garantisce una maggiore rigidità di spacco e una perfetta visibilità della rotella di incisione

The KLICK KLOCK system ensures greater splitting rigidity and a perfect visibility of the cutting wheel

L'impugnatura scorre sulla guida appoggiandosi su un cuscinetto a sfere

The grip slides on the guide leaning on a ball bearing

Protezione antisegno intercambiabile

Protection to prevent marks interchangeable



sigmaitalia

international patents

Art.									
3LK	52,4 cm 20,6 inc	37,0 cm 14,5 inc	0-19 mm 3/4 inc	1200 Kg	7,7 Kg	2 pz 16,9 Kg	78 x 42 x 30 cm	36 pz.	
3B4K	64,4 cm 25,3 inc	45,5 cm 17,9 inc	0-19 mm 3/4 inc	1200 Kg	10,3 Kg	2 pz 22,2 Kg	92 x 41 x 31 cm	36 pz.	
3C2K	74,4 cm 29,2 inc	52,6 cm 20,7 inc	0-19 mm 3/4 inc	1200 Kg	11,6 Kg	1 pz 13,1 Kg	104 x 41 x 24 cm	16 pz.	
3D4K	92,4 cm 36,3 inc	65,3 cm 25,7 inc	0-19 mm 3/4 inc	1200 Kg	13,2 Kg	1 pz 15,0 Kg	123 x 42 x 23 cm	16 pz.	
3P2K	102,4 cm 40,3 inc	72,4 cm 28,5 inc	0-19 mm 3/4 inc	1200 Kg	17,0 Kg	1 pz 18,5 Kg	137 x 46 x 20 cm	16 pz.	
3E4K	129,8 cm 51,1 inc	91,7 cm 36,1 inc	0-19 mm 3/4 inc	1200 Kg	21,0 Kg	1 pz 22,6 Kg	164 x 46 x 20 cm	10 pz.	



 Incisione a spinta

 Pushing incision

 Incision à pousser

 Incision zu drücken

# SERIE 3 KLICK KLOCK

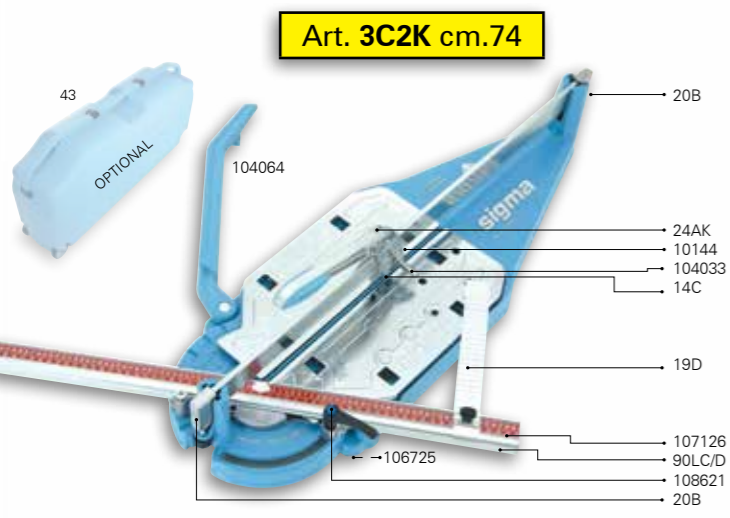
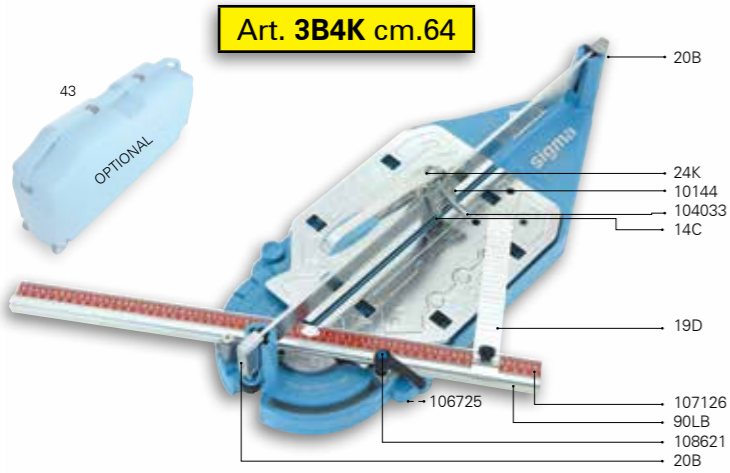
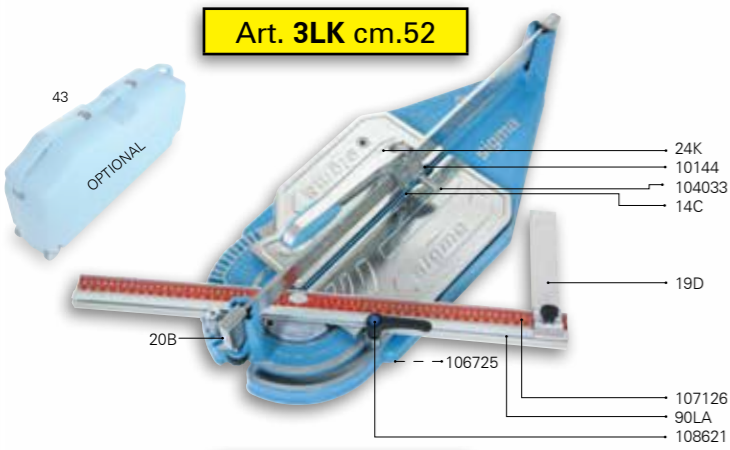

Art.	Descrizione	Description	
3LK	TAGLIA PIASTRELLE cm.52	TILE CUTTER cm.52	2
3B4K	TAGLIA PIASTRELLE cm.64	TILE CUTTER cm.64	2
3C2K	TAGLIA PIASTRELLE cm.74	TILE CUTTER cm.74	1
Tile cutters may be available with the inch measurement bar			
Accessori a richiesta		Accessoires on request	
90E4	Misura anteriore da 30 a 400mm per art. 3GK-3LK-3B4K-3C2K (taglio utile = max - 5cm.)	Front measure from 30 to 400mm for art 3LK -3B4K -3C2K (working cut = max - 5cm.)	1
43	Valigia con ruote per Art. 3GK-3LK-3B4K-3C2K. Dimensioni 1030 x 500 x 227mm.	Suitcase with wheels for Art.3GK-3LK-3B4K-3C2K Dimensions 1030x500x227mm	1
14CT	Rotella per incisione al TITANIO, Ø mm 15 completa	Ø 15 mm TITANIUM scoring wheel, complete	20
104064	Supporto Sx completo.	Complete Left support.	1
104065	Supporto Dx completo.	Complete Right support.	1
Ricambi		Spare parts	
14C	Rotella per incisione Ø 15 mm completa.	Ø 15 mm complete scoring wheel	20
24K	Impugnatura KLICK KLOCK a spinta scavo 8 mm, con protezioni antisegno, completa di Art.14C per Art.3GK-3LK-3B4K	KLICK KLOCK pushing handle 8 mm groove, with Art.14C, NO-MARK protection, for Art.3GK-3LK-3B4K	1
24AK	Impugnatura KLICK KLOCK a spinta scavo 10 mm, con protezioni antisegno, completa di Art.14C per Art.3C2K.	KLICK KLOCK pushing handle 10 mm groove, with Art.14C, NO-MARK protection, for Art. 3C2K.	1
104033	Protezione sottopiede antisegno per leva Art. 24K-24AK	NO-MARK protection for pushing handle Art. 24K-24AK	1
10144	Cuscinetto a sfere rinforzato 16/5/5.	Reinforced ball bearing 16/5/5.	1
19D	Squadretta lunga 260 mm.	Square 260 mm. long	1
90LA	Barra metrica orientabile per Art. 3LK. 41-0-33cm.	Swivel measurement bar for Art. 3LK.	1
90LB	Barra metrica orientabile per Art.3B4K. 47-0-35cm.	Swivel measurement bar for Art.3B4K.	1
90LC	Barra metrica orientabile per Art. 3C2K. 54-0-40cm.	Swivel measurement bar for Art.3C2K.	1
107126	Righetta metrica adesiva per art. 3/ABCDEFGLP.	Adhesive measurement tape for art.3/ABCDEFGLP.	1
108621	Pomolo a leva M8x40 per art. 3	Clamping knob lever M8x40 for art. 3	1
1079104	Dado M8 Esagono 20 per Pomolo a leva.	Nut M8 Hex 20 for Clamping knob lever.	1
20B	Bilico scavo 15 completo per art.3/ABCDGL/K.	Complete adjustable support screw 15 for art.3	1
106725	Tappo piede 20/25 H24 per Art.3/ABCDGL/K.	Rubber foot 20/25 H24 for Art. 3/ABCDGL/K.	1
Vendita a confezioni intere		Sold in full packs only	

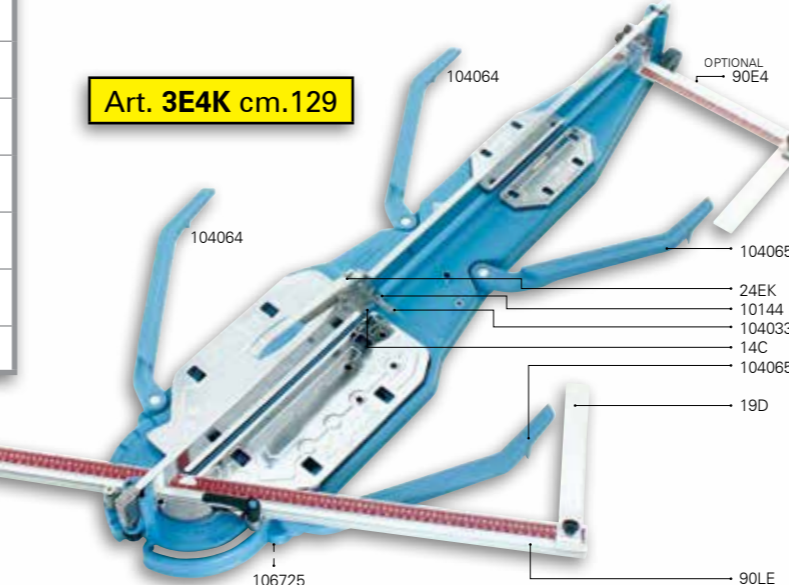
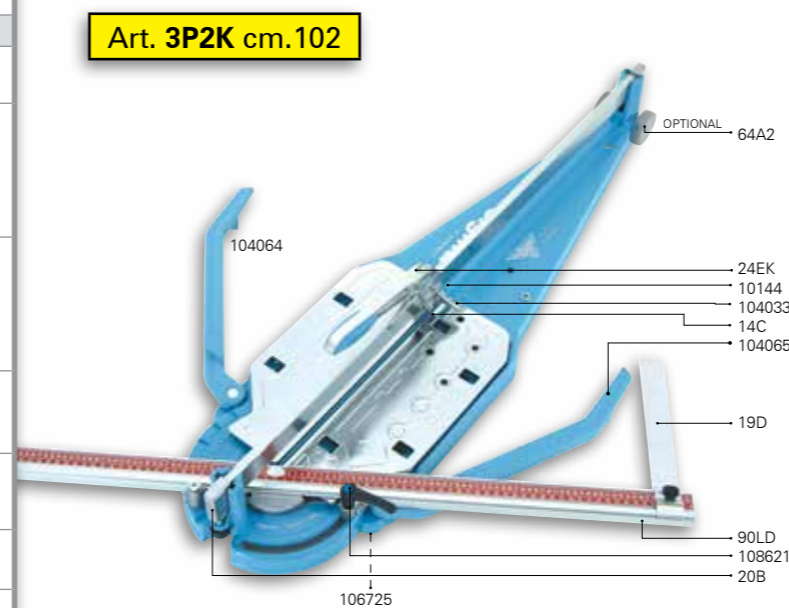
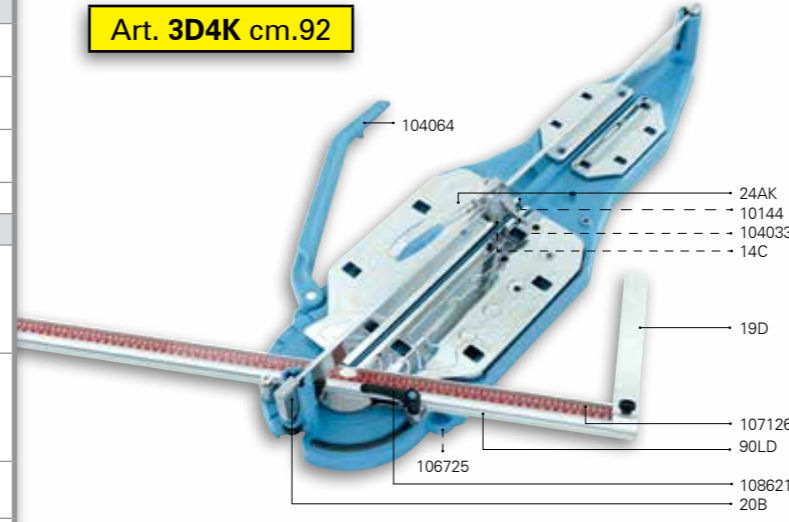

Art.	Descrizione	Description	
3D4K	TAGLIA PIASTRELLE cm.92	TILE CUTTER cm.92	1
3P2K	TAGLIA PIASTRELLE cm.102	TILE CUTTER cm.102	1
3E4K	TAGLIA PIASTRELLE cm.129	TILE CUTTER cm.129	1
Tile cutters may be available with the inch measurement bar			
Accessori a richiesta		Accessoires on request	
43D1	Valigia in tela imbottita con ruote per Art. 3D4K	Canvas padded case with wheels for Art. 3D4K	2
43E1	Valigia in tela imbottita con ruote per Art. 3E4K	Canvas Padded case with wheels for Art. 3E4K	2
90E4	Misura anteriore da 30 a 400mm per art. 3D4K-3P2K-3E4K (taglio utile = max - 5cm.)	Front measure from 30 to 400mm for art 3D4K-3P2K-3E4K (working cut = max - 5cm.)	1
14CT	Rotella per incisione I TITANIO, Ø mm 15 completa	Ø 15 mm TITANIUM scoring wheel, complete	20
64A2	Gruppo ruote per 3P2K	wheel unit for 3P2K	1
Ricambi		Spare parts	
14C	Rotella per incisione Ø 15 mm completa.	Ø 15 mm complete scoring wheel	20
24AK	Impugnatura KLICK KLOCK a spinta scavo 10 mm, con protezioni antisegno, completa di Art.14C per Art.3D4K.	KLICK KLOCK pushing handle 10 mm groove, with Art.14C, NO-MARK protection, for Art. 3D4K.	1
24EK	Impugnatura KLICK KLOCK a spinta scavo 15 mm, con protezioni antisegno, completa di Art.14C per Art.3P2K-3E4K.	KLICK KLOCK pushing handle 15 mm groove, with Art.14C, NO-MARK protection, for Art. 3P2K-3E4K	1
104033	Protezione sottopiede antisegno per leva Art. 24AK-24EK	NO-MARK protection for pushing handle Art. 24AK-24EK	1
10144	Cuscinetto a sfere rinforzato 16/5/5.	Reinforced ball bearing 16/5/5.	1
19D	Squadretta 260mm per art.3	260mm Square for art.3	1
90LD	Barra metrica orientabile per Art. 3D4K-3P2K 64-0-46cm.	Swivel measurement bar for Art.3D4K-3P2K.	1
90LE	Barra metrica orientabile per Art. 3E4K 64-0-64cm.	Swivel measurement bar for Art. 3E4K.	1
107126	Righetta metrica adesiva per art. 3*	Adhesive measurement tape for art.3*	1
108621	Pomolo a leva M8x40 per Art. 3*	Clamping knob lever M8x40 for Art. 3*	1
1079104	Dado M8 Esagono 20 per Pomolo a leva.	Nut M8 Hex 20 for Clamping knob lever.	1
20B	Bilico scavo 15 completo per Art. 3*	Complete adjustable support screw 15 for Art. 3*	1
106725	Tappo piede 20/25 H24 per Art. 3*	Rubber foot 20/25 H24 for Art. 3*	1

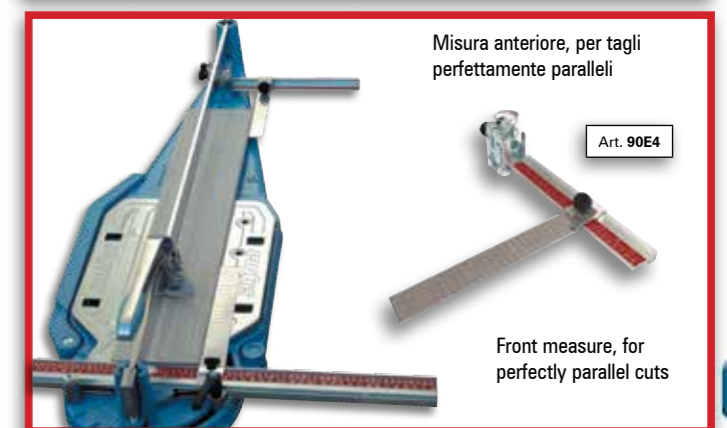



**Incisione a spinta**

**Pushing incision**

**Incision à pousser**

**Incision zu drücken**

# SERIE XL



**TAGLIAPIASTRELLE PER GRANDI DIMENSIONI**

**TILE CUTTER FOR BIG SIZES**

**COUPE-CARREAUX POUR LES GRANDES DIMENSIONS**

**FLIESENSCHNEIDER FÜR GROSSE GRÖSSEN**

"XL" Grande tagliapiastrelle con struttura e guida di scorrimento in lega leggera temprata e indurita. L'impugnatura con incisione a spinta ammortizzata, scorre completamente su cuscinetti a sfere e guide inox. Dotata di doppia misura per tagli paralleli e di appoggio orientabile da +45° a -45°.

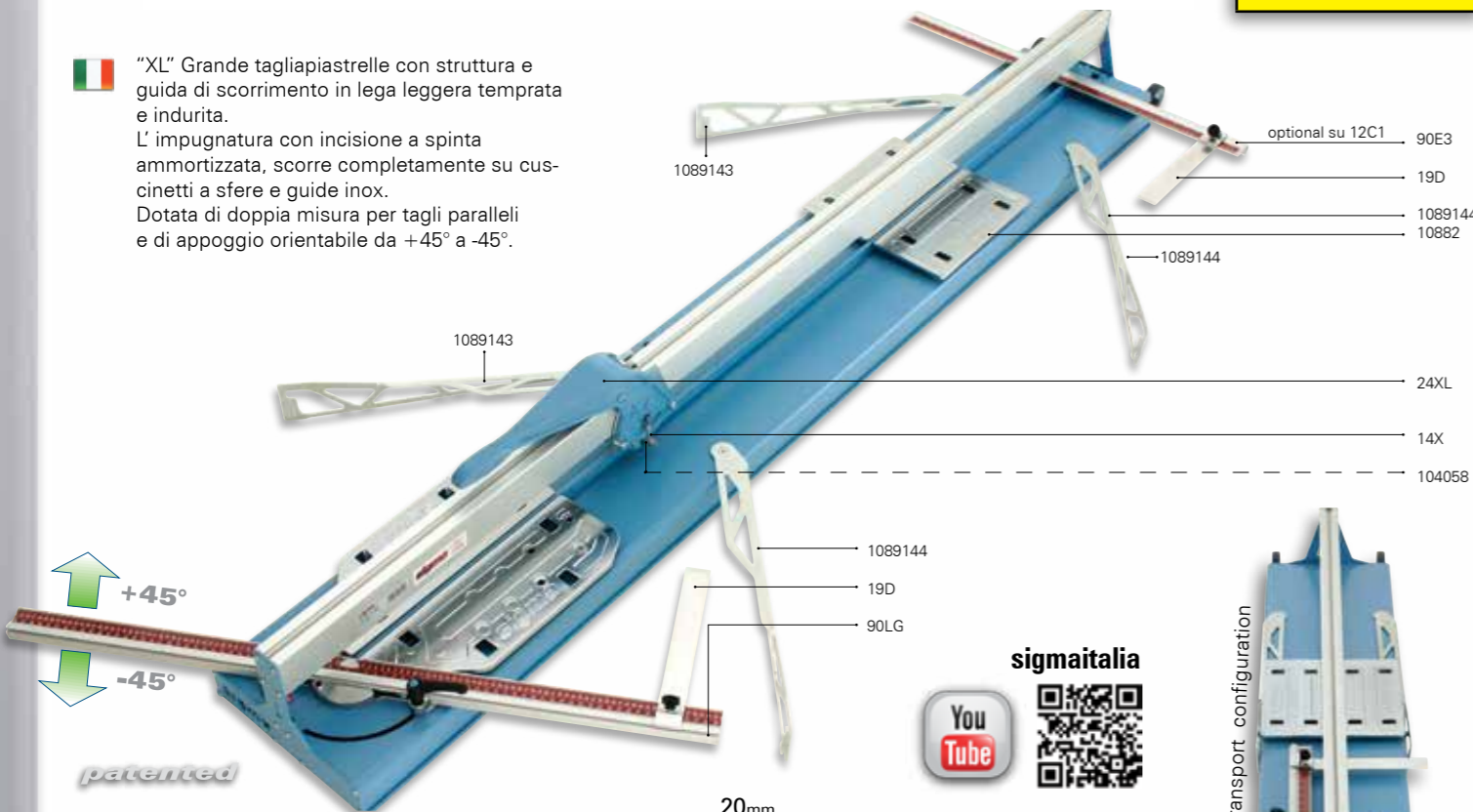

**Art. 12C1 cm.155**

**Art. 12D1 cm.205**

**Art. 12E1 cm.245**

"XL" Big tile cutter with frame and sliding guide made of light hardened aluminium alloy. The push handle with cushioned scoring, runs completely on ball bearings and stainless steel runners. Equipped with a double measures for parallel cuts and pivoting support from +45° to -45°.

"XL" Grande coupe-carreaux avec cadre et glissières en alliage léger et trempé. La poignée à pousser avec incision coussinée, va complètement sur roulements à billes et chemins en acier inoxydable. Equipé d'un double Mesures pour coupes parallèles et support pivotant de +45° à -45°.

"XL" Big Fliesenschneider mit Rahmen und Schiebeführung aus gehärtet Leichtmetall. Der Schiebegriff mit gepolsterter Gravur, läuft komplett auf Kugellagern und Edelstahl-Läufer. Ausgestattet mit einem Dual-Messskala für parallele Schnitte und Schwenk Unterstützung von +45° bis -45°.

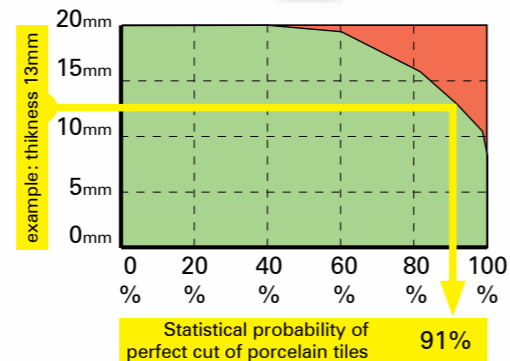

Art.									
12C1	155 cm 61,0 inc	109 cm 42,9 inc	0-19 mm 3/4 inc	770 Kg.	31 Kg.	1 pz. 35 Kg.	192 x 36 x 32 cm	10 pz.	
12D1	205 cm 80,7 inc	145 cm 57,0 inc	0-19 mm 3/4 inc	770 Kg.	36 Kg.	1 pz. 40 Kg.	242 x 36 x 32 cm	10 pz.	
12E1	245 cm 96,4 inc	173 cm 68,0 inc	0-19 mm 3/4 inc	770 Kg.	39 Kg.	1 pz. 43 Kg.	282 x 36 x 32 cm	10 pz.	

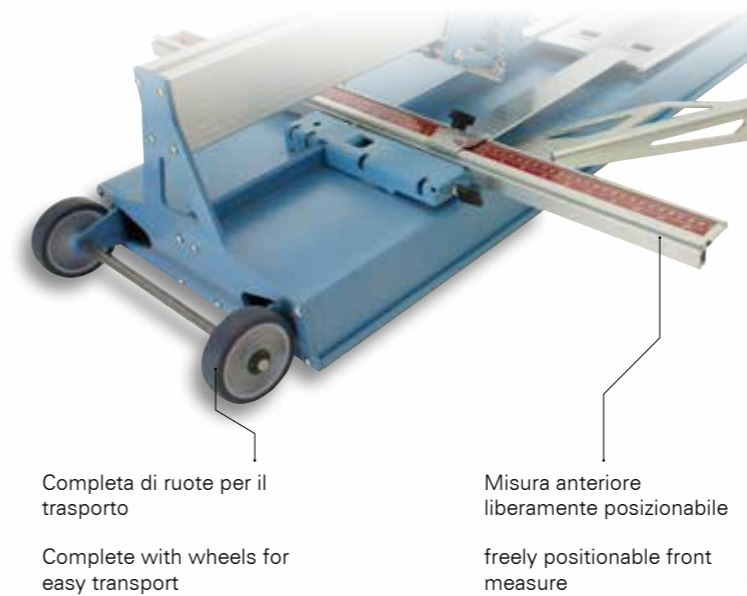

Art.	Descrizione	Description		
12C1	TAGLIAPIASTRELLE cm.155	TILE CUTTER cm.155	1	
12D1	TAGLIAPIASTRELLE cm.205 completa di 90E3	TILE CUTTER cm.205 complete with art. 90E3	1	
12E1	TAGLIAPIASTRELLE cm.245 completa di 90E3	TILE CUTTER cm.245 complete with art. 90E3	1	
Tile cutters may be available with the inch measurement bar				
Ricambi		Spare parts		
90E3	Misura anteriore 410-0-410 mm con art.19D	Front measure 410-0-410 mm with art.19D	1	
14X	Rotella per incisione Ø 13 mm f.4 s.4 completa.	Ø 13 mm complete scoring wheel, h.4 t.4	20	
104058	Protezione sottopiede antisegno per leva 12/CDE	no-mark protection for 12/CDE handle	1	
90LG	Barra metrica orientabile per Art. 12/CDE 55-0-55cm.	Swivel measurement bar for Art.12/CDE 55-0-55cm.	1	



Impugnatura ergonomica, ottimizzata per incisione a spinta  
Ergonomic handle, optimized for pushing cutting

Doppio molleggio per una incisione ammortizzata, indispensabile per la lavorazione di piastrelle rugose o con superficie strutturata

Double springing for an cushioned incision, which is essential for the working of tiles with rough or textured surface

Piede di spacco molto largo, 100mm, ottimale per il taglio facile di grandi piastrelle

Foot gap very wide, 100mm, perfect for easy cutting large tiles

Piede di spacco in lega di alluminio, leggero ma rigido, per uno spacco efficace

Gap foot of aluminum alloy, light but rigid, for a effective split

Protezione antisegno intercambiabile

Protection to prevent marks interchangeable

L'impugnatura scorre sulla guida inox, appoggiandosi su tre cuscinetti con 6 corone di sfere, per una incisione perfettamente rettilinea nel tempo.

The handle slides on the steel rails, laying on 3 bearings with 6 ball rings, for a perfectly straight incision over the time.

La rotella è dotata di sistema di recupero del gioco laterale

The wheel is equipped with a recovery system of side clearance

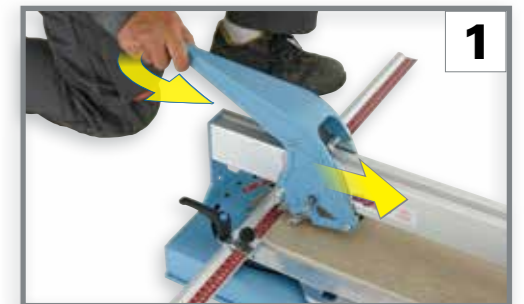



Tagliapiastrelle

Coupe Carreaux

Tile Cutters

Fliesenschneider

# TECNICA



Incisione a trazione o a spinta

Pulling or pushing incision

Incision en traction ou en poussée

Ritzen durch Ziehen oder Schieben

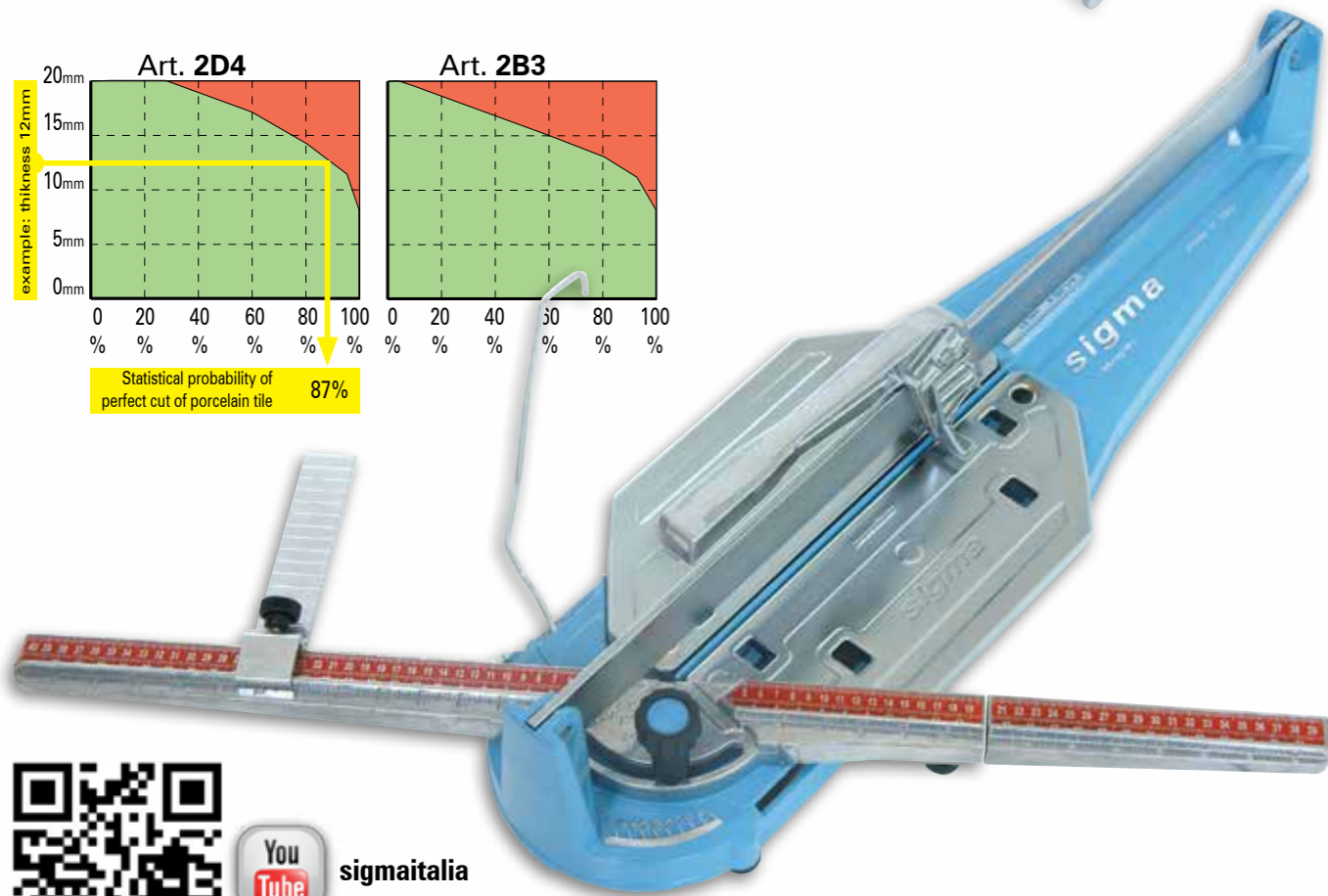
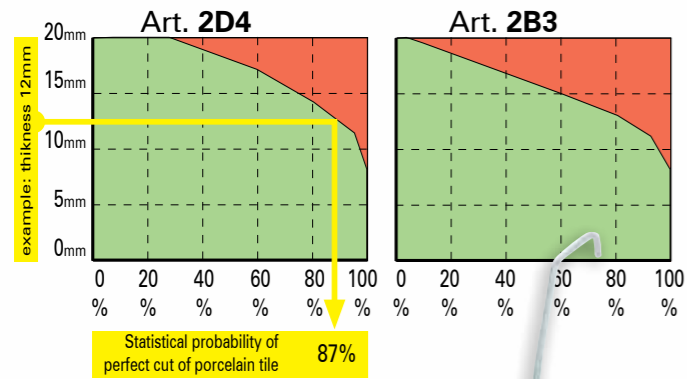

international patents



2B3 Incisione a trazione

Spacco

2D4 Incisione a spinta

2B3 Pulling incision system

Breaking

2D4 Pushing incision system

2B3 Incision à traction

Sectionnement

2D4 Incision à poussée

2B3 Ritzen durch Ziehen

Brechen

2D4 Ritzen durch Schieben

Incisione veloce a trazione fast pulling incision

Art. 2B3 cm.66

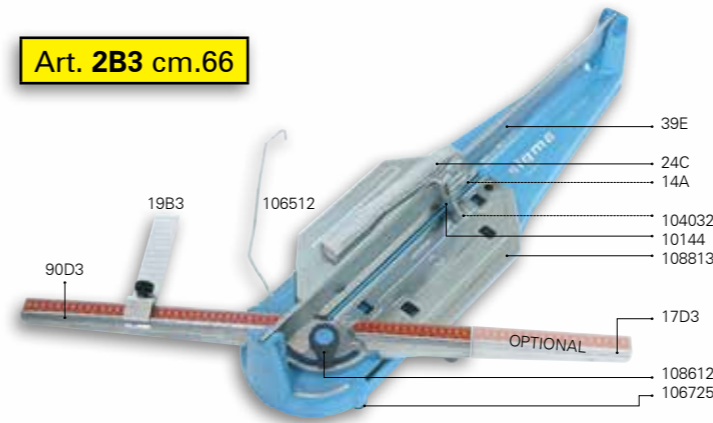

Incisione forte a spinta strong pushing incision

Art. 2D4 cm.61

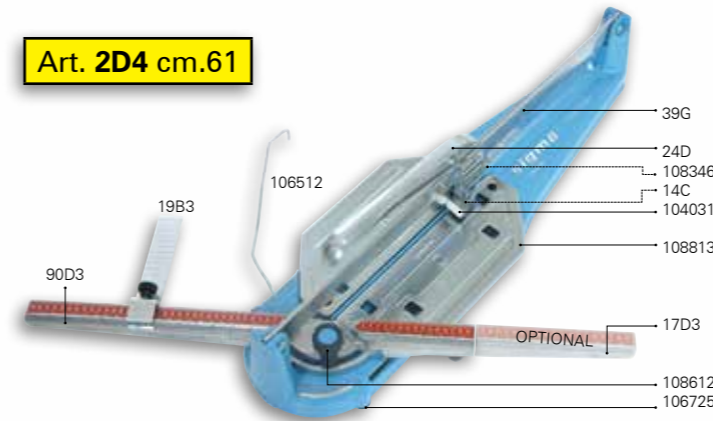

Art.	Descrizione	Description	
	Incisione veloce a trazione	fast pulling incision	
2B3	TAGLIA PIASTRELLE cm.66	TILE CUTTER cm.66	3
	Incisione forte a spinta	strong pushing incision	
2D4	TAGLIA PIASTRELLE cm.61	TILE CUTTER cm.61	3
Tile cutters may be available with the inch measurement bar			
Accessori a richiesta		Accessoires on request	
43	Valigia con ruote per Art. 2B 2D. Dimensioni 1030 x 500 x 227mm	Suitcase with wheels for Art. 2B 2D. Dimensions 1030 x 500 x 227mm	1
17D3	Prolunga metrica da 21 a 40 cm. per Art. 2B3-2D4	Calibrated extension from 21 to 40 cm. for Art. 2B3-2D4	1
14T	Rotella per incisione TITANIO, Ø 12 mm 12, completa, per Art. 2B3	Ø 12 mm TITANIUM scoring wheel, complete, for Art. 2B3	20
14CT	Rotella per incisione al TITANIO, Ø 15 mm 15, completa, per Art. 2D4	Ø 15 mm TITANIUM scoring wheel, complete, for Art. 2D4	20
Ricambi		Spare parts	
14A	Rotella per incisione Ø 12 mm completa, per Art. 2B3	Ø 12 mm scoring wheel, complete, for Art. 2B3	20
14C	Rotella per incisione Ø15 mm completa, per Art. 2D4	Ø 15 mm scoring wheel, complete, for Art. 2D4	20
24C	Impugnatura a trazione scavo 7, con protezioni antisegno, completa di Art. 14A per Art. 2B3.	pulling handle 7 mm groove, with Art. 14A, NO-MARK protection, for Art. 2B3.	1
24D	Impugnatura a spinta con protezioni antisegno, completa di Art. 14C per Art. 2D4	Pushing handle, 7 mm groove, with Art. 14C, NO-MARK protection, for Art. 2D4	1
104032	Protezione sottopiede antisegno per Art. 2B3	NO-MARK protection for Art. 2B3	1
104031	Protezione sottopiede antisegno per Art. 2D4	NO-MARK protection for Art. 2D4	1
10144	Cuscinetto a sfere 5/16/5 per Art. 2B3	Ball bearing 5/16/5 for Art. 2B3	1
108346	Cuscinetto 12/5/6,5 per Art. 2D4	Bearing 12/5/6,5 for Art. 2D4	1
90D3	Barra metrica orientabile per Art. 2B3-2D4	Swivel measurement bar for Art. 2B3-2D4	1
107112	Righetta metrica 402 0 197 per Art. 90D3	Measurement tape 402 0 197 for Art. 90D3	1
19B3	Squadretta per Art. 2B3-2D4	Square for Art. 2B3-2D4	1
108612	Pomolo Ø40 M10x35	Clamping knob Ø40 M10x35	1
108813	Piatto per Art. 2B3-2D4	Plane for Art. 2B3-2D4	2



Art.								
2B3	66 cm 26,0 inc	46 cm 18,3 inc	3-19 mm 3/4 inc	800 Kg	7,0 Kg	3 pz. 24,0 Kg.	85 x 42 x 29 cm.	54 pz.
2D4	61 cm 24,0 inc	43 cm 17,0 inc	6-19 mm 3/4 inc	800 Kg	7,0 Kg	3 pz. 24,0 Kg.	85 x 42 x 29 cm.	54 pz.



Tagliapiastrelle

Coupe Carreaux

Tile Cutters

Fliesenschneider

STANDARD

**sigma**  
di Ambrogiani

Incisione a trazione, pratica e veloce

Pulling incision, fast and practical

Incision à tirer, rapide et pratique

Praktisches und schnelles Ritzen durch Ziehen

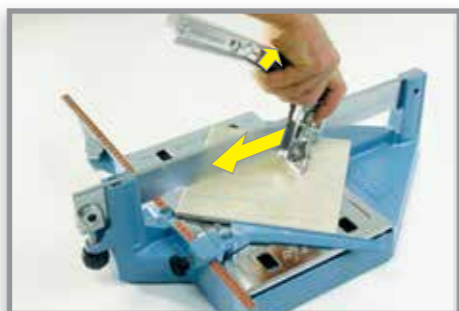
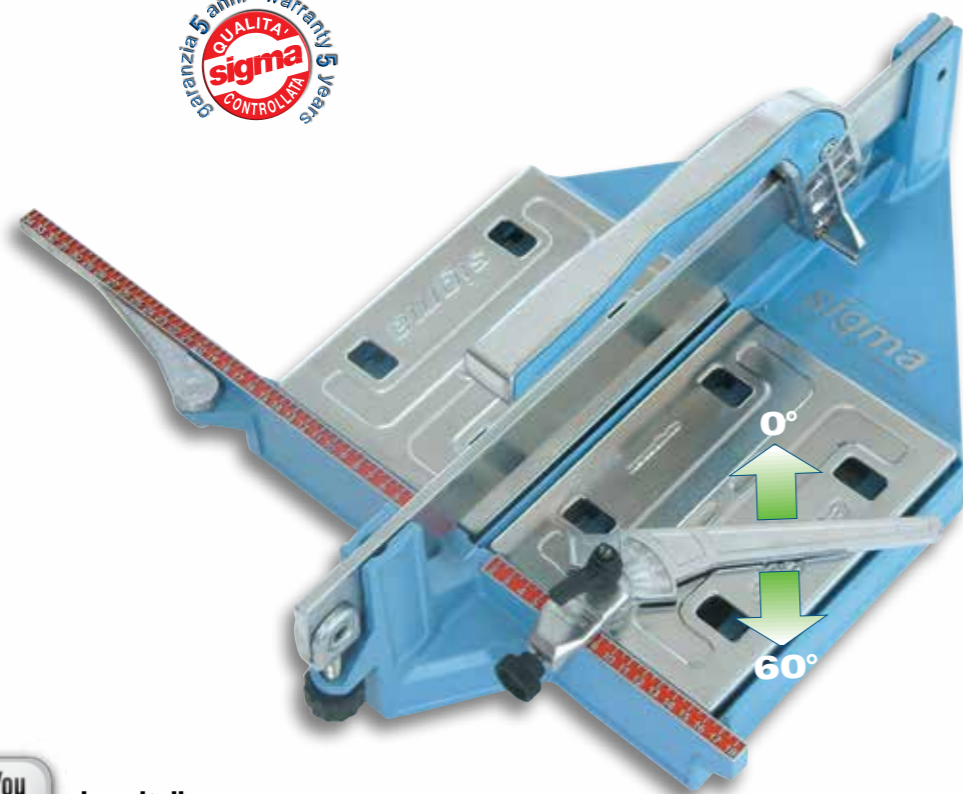

Art. 6 Regolazione dello spessore

Incisione

Spacco

Art. 6 Regulation of cutting thickness

Incision

Breaking

Art. 6 Vis de réglage

Incision

Sectionnement

Art. 6 Einstellen der Brechleistung

Ritzen

Brechen

Art. 7F cm.37

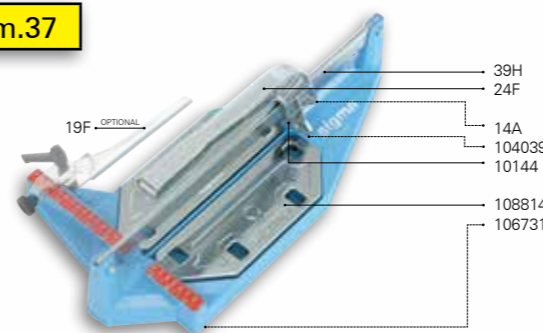

Art. 6 cm.35

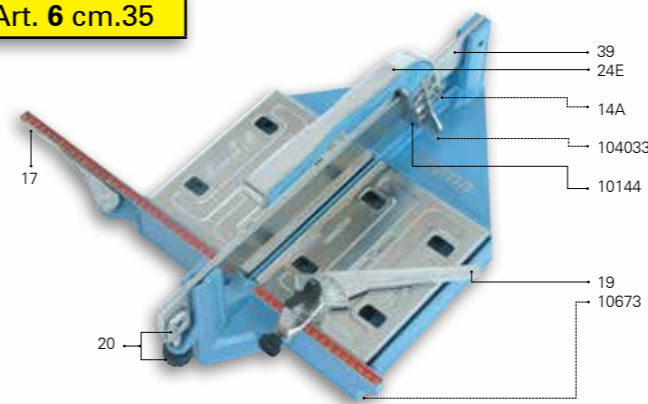

Art.	Descrizione	Description	
7F	TAGLIA PIASTRELLE cm.37 versione professionale doppia misura, mm e pollici	TILE CUTTER cm.37 professional version double measuring, mm and inches	6
6	TAGLIA PIASTRELLE cm.35 completa	TILE CUTTER cm.35 complete	4
Accessori a richiesta		Accessoires on request	
14T	Rotella per incisione al TITANIO, Ø mm 12 completa	Ø 12 mm TITANIUM scoring wheel, complete	20
19	Squadretta orientabile 0°-60° per Art. 7A-6	Swivelling support 0°-60° for Art. 7A-6	1
19F	Squadretta orientabile 0°-60° per Art. 7F-7E	Swivelling support 0°-60° for Art. 7F-7E	1
Ricambi		Spare parts	
14A	Rotella per incisione Ø12 mm completa di asse Art.15A	Ø12 mm Complete scoring wheel with spindle art.15A	20
24F	Impugnatura a trazione scavo 6 completa per Art. 7F con protezioni antisegno	Pulling handle 6 mm groove complete for Art.7F NO-MARK protection	1
24E	Impugnatura a trazione scavo 8, con protezioni antisegno, completa di Art.14A per Art.6	Pulling handle 8 groove, complete with Art.14A, NO-MARK protection, for Art.6	1
104039	Protezione sottopiede antisegno per leva Art. 24F	NO-MARK protection for Pulling handle Art. 24F	1
104033	Protezione sottopiede antisegno per leva Art. 24E	NO-MARK protection for Pulling handle Art. 24E	1
10144	Cuscinetto a sfere rinforzato 16/5/4,7 per Art.24E-24F	Reinforced ball bearing 16/5/4,7 for Art.24E-24F	1
17	Prolunga metrica ripiegabile da 21 a 34 cm	Folding calibrated extension from 21 to 34 cm	1
10673	Tappo piede diam.14 per Art.6	Rubber foot dia.14 for Art.6	1
106731	Tappo piede 13/17 H16 per Art. 7F.	Rubber foot 13/17 H16 for Art. 7F.	1
20	Bilico completo scavo 8	Complete adjustable support screw 8	1

Vendita a confezioni intere Sold in full packs only

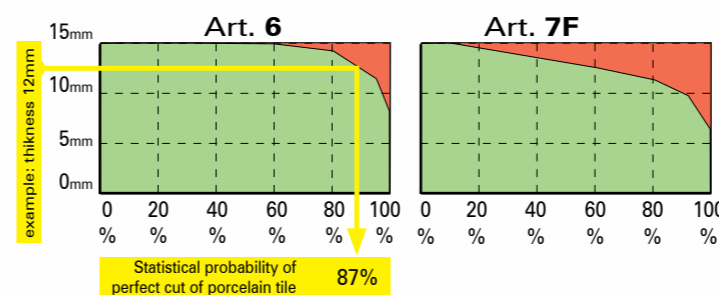

Probabilità statistica di taglio perfetto su piastrelle in gres porcellanato

Statistical probability of perfect cut of porcelain tiles

Probabilité statistique de coupe parfaite des carreaux en grès cérame

Statistische Wahrscheinlichkeit von perfekten Schnitten an Feinsteinzeugfliesen

Art.								
7F	37 cm 14,5 inc	26 cm 10,3 inc	3-15 mm 9/16 inc	600 Kg.	2,3 Kg.	6 pz. 15,3 Kg.	54 x 43 x 32 cm.	120 pz.
6	35 cm 13,7 inc	25 cm 9,7 inc	0-15 mm 9/16 inc	800 Kg.	4,6 Kg.	4 pz. 21,5 Kg.	83 x 55 x 28 cm.	48 pz.





**NEW**



"COMBIFLEX" è la pratica sega portatile che permette il taglio segato di piastrelle con spessore fino a 30mm sia a secco che ad acqua. Grazie alla sua struttura in alluminio leggera ma robusta garantisce un facile e comodo trasporto anche negli spazi più ridotti. Il suo peso contenuto (19 kg per 8LF da 90 cm e 21 kg per 8LG da 120cm) la rende la sega portatile più leggera sul mercato. Il gruppo carrello scorre con 3 cuscinetti a doppia corona di sfere su una guida di scorrimento in alluminio con piste in acciaio INOX estremamente durevoli nel tempo. E' possibile collegare qualsiasi smerigliatrice fino a 1400W grazie al suo attacco universale ed utilizzare un disco da 115/125mm di diametro. Il COMBIFLEX è predisposto per l'aspirazione delle polveri, per il taglio a secco senza diffondere polvere nell'aria. Sono disponibili accessori: "Kit gambe", completamente in alluminio e ripieghevole, per rendere il COMBIFLEX ancora più comodo e pratico da usare e il "WaterKit" che permette un taglio ad acqua accurato e veloce senza diffondere polvere, usabile in alternativa alla aspirazione a secco.



"COMBIFLEX" is the practical handheld saw that allows the sawing of tiles up to 30mm thick, both dry and water-sawn. Thanks to its light but sturdy aluminium structure it guarantees an easy and comfortable transport even in the smallest spaces. Its light weight (19 kg for 8LF of 90 cm and 21 kg for 8LG of 120 cm) makes it the lightest portable saw on the market. The trolley unit slides with 3 double row ball bearings on an aluminum sliding rail with stainless steel tracks extremely durable over time. It is possible to connect any grinder up to 1400W thanks to its universal attachment and use a 115/125mm diameter disc. The COMBIFLEX is designed for dust extraction, for dry cutting without spreading dust in the air. Accessories are available: "Leg Kit", completely in aluminium and foldable, to make the COMBIFLEX even more comfortable and practical to use and the "WaterKit" that allows an accurate and fast water cutting without spreading dust, usable as an alternative to dry suction.



"COMBIFLEX" est la scie à main pratique qui permet de scier des carreaux jusqu'à 30 mm d'épaisseur, à sec ou à l'eau. Grâce à sa structure légère mais robuste en aluminium, elle garantit un transport facile et confortable même dans les espaces les plus réduits. Son poids léger (19 kg pour 8LF de 90 cm et 21 kg pour 8LG de 120 cm) en fait la scie portable la plus légère du marché. L'unité de chariot coulisse sur 3 roulements à billes à double rangée sur un rail de glissement en aluminium avec des rails en acier inoxydable extrêmement résistants dans le temps. Il est possible de raccorder n'importe quelle meuleuse jusqu'à 1400 W grâce à sa fixation universelle et d'utiliser un disque de 115/125 mm de diamètre. Le combiflex est conçu pour l'extraction de la poussière, pour une coupe à sec sans dispersion de la poussière dans l'air. Des accessoires sont disponibles : Le "Leg Kit", entièrement en aluminium et pliable, pour rendre le Combiflex encore plus confortable et pratique à utiliser et le "WaterKit" qui permet une coupe à l'eau précise et rapide sans dispersion de poussière, utilisable comme alternative à l'aspiration à sec.



**NEW**

**Art. 8LG**

**Art. 452**  
optional  
**NEW**

**Art. 87E4**  
optional  
**NEW**

**patented**

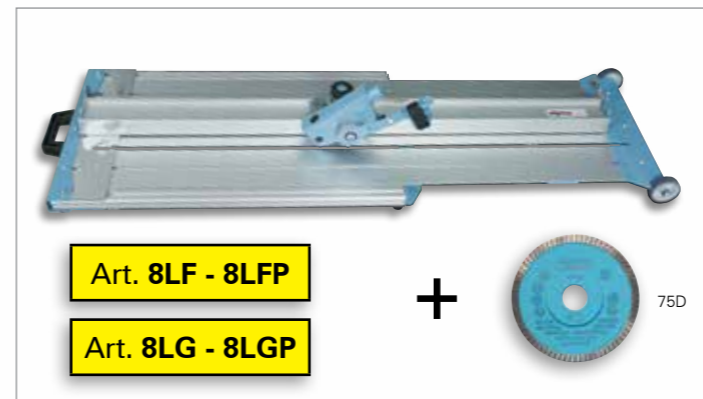

**Art. 8LF - 8LFP**

**Art. 8LG - 8LGP**



**Art. 452**



**NEW**

**Art. 87E4**

Art.	Descrizione	Description	
<b>8LF</b> <b>NEW</b>	COMBIFLEX cm.91 con disco 75D predisposto per smerigliatrice, attacco universale filetto M14	COMBIFLEX cm.91 with blade 75D prepared for grinder, universal spindle thread M14	1
<b>8LFP</b> <b>NEW</b>	COMBIFLEX cm.91 con disco 75D predisposto per smerigliatrice, attacco universale filetto 5/8-11 UNC per U.S.A. Canada	COMBIFLEX cm.91 with blade 75D prepared for grinder, universal spindle thread 5/8-11 UNC for U.S.A. Canada	1
<b>8LG</b> <b>NEW</b>	COMBIFLEX cm.121 con disco 75D predisposto per smerigliatrice, attacco universale filetto M14	COMBIFLEX cm.121 with blade 75D prepared for grinder, universal spindle thread M14	1
<b>8LGP</b> <b>NEW</b>	COMBIFLEX cm.121 con disco 75D predisposto per smerigliatrice, attacco universale filetto 5/8-11 UNC per U.S.A. Canada	COMBIFLEX cm.121 with blade 75D prepared for grinder, universal spindle thread 5/8-11 UNC for U.S.A. Canada	1
	Accessori a richiesta	Accessoires on request	
<b>452</b> <b>NEW</b>	Kit gambe per COMBIFLEX	Legs Kit for COMBIFLEX	1
<b>87E4</b> <b>NEW</b>	Waterkit sistema di raffreddamento per l'utensile diamantato con nebulizzazione d'acqua (10lit), garantisce maggior velocità e finitura. Compatibile anche per versioni precedenti. Necessario l'utilizzo di smerigliatrice a batteria.	Waterkit cooling system for the diamond tool with water spray (10lit), guarantees better speed and finish. Also compatible for previous versions. The use of a cordless grinder is necessary.	1
<b>458</b>	fissaggio extra per Waterkit 87E4	extra fixing for Waterkit 87E4	1
	<b>Ricambi</b>	<b>Spare parts</b>	
<b>75C3</b> <b>NEW</b>	Disco diamantato Ø 115mm foro 22,2 mm, spes.1,1 mm per materiali da 3 a 15 mm	Diamond blade Ø 115mm Hole 22.2mm, thickness 1.1mm for materials from 3 to 15 mm	10
<b>75D</b>	Disco diamantato Ø 125 mm foro 22,2 mm, spes.1,4 mm per materiali da 5 a 30 mm di spessore	Diamond disc Ø 125 mm bore 22,2 mm, thick 1,4 mm for materials from 5 to 30 mm thick	10

"COMBIFLEX" ist die praktische Handsäge, die das Sägen von Fliesen bis zu 30 mm Dicke ermöglicht, sowohl trocken als auch wassergesägt. Dank ihrer leichten aber robusten Aluminiumstruktur garantiert sie einen einfachen und bequemen Transport auch auf kleinstem Raum. Ihr geringes Gewicht (19 kg für 8LF von 90 cm und 21 kg für 8LG von 120 cm) macht sie zur leichtesten tragbaren Säge auf dem Markt. Die Wageneinheit gleitet mit 3 doppelreihigen Kugellagern auf einer Aluminiumgleitschiene mit Edelstahlgleitschienen, die extrem langlebig ist. Dank der Universalbefestigung ist es möglich, jede Schleifmaschine bis 1400 W anzuschließen und eine Scheibe mit 115/125 mm Durchmesser zu verwenden. Die COMBIFLEX ist für Staubabsaugung ausgelegt, für Trockenschnitt ohne Staubverteilung in der Luft. Zubehör ist erhältlich: "Bein-Kit", komplett aus Aluminium und zusammenklappbar, um den COMBIFLEX noch komfortabler und praktischer in der Anwendung zu machen, und das "WaterKit", das einen präzisen und schnellen Wasserschleif ermöglicht, ohne Staub zu verteilen, verwendbar als Alternative zur Trockenabsaugung.



Art.							
<b>8LF - 8LFP</b>	91 cm 36 inc	64 cm 25 inc	0 ⇨ 30 mm 1 3/16	18,8 Kg	20,8 Kg.	130,5 x 50 x 20 cm	
<b>8LG - 8LGP</b>	121 cm 48 inc	86 cm 33 inc	0 ⇨ 30 mm 1 3/16	20,8 Kg	22,8 Kg.	160,5 x 50 x 20 cm	
<b>452</b>				6,8 Kg	8,0 Kg.	129 x 20 x 15 cm	



🇮🇹 VERSIONE ESTENSIBILE

🇬🇧 EXTENSIBLE VERSION

KERA-CUT EXT

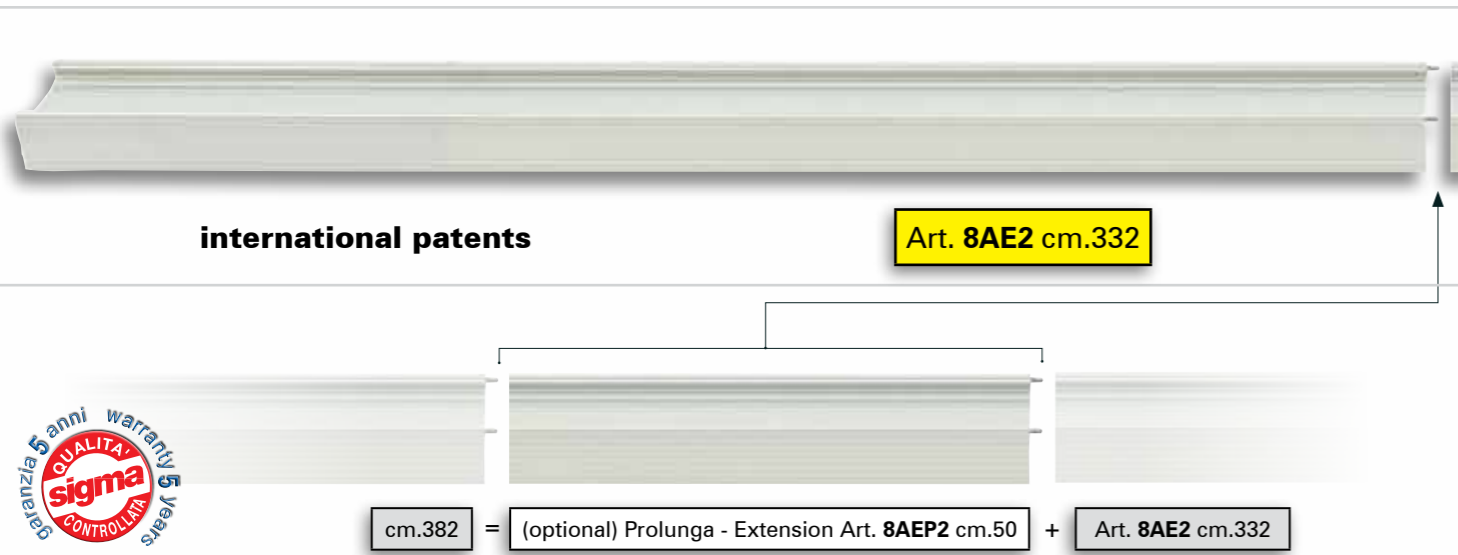

🇮🇹 KERA-CUT EXT: attrezzatura di taglio per piastrelle di grande formato. La guida in alluminio, fissata sulla piastrella tramite ventose antimacchia, permette lo scorrimento del carrello con rotellina di incisione. Successivamente la separazione si effettua con la pinza in dotazione. Con questo sistema si possono tagliare anche piastrelle di spessore superiore a 7mm (solo su Gres porcellanato morbido) con l'ausilio del separatore Art. 41D. Per il trasporto le guide e tutti gli accessori sono contenuti nelle due valigie in dotazione. In alternativa, per tagliare materiali spessi e particolarmente duri, un carrello porta smerigliatrice consente un taglio segato con disco diamantato (vedi pag. 35).

🇬🇧 KERA-CUT EXT: cutting equipment for large format tiles; the divisible aluminum guide, fixed on the tile by stain-free suction cups, allows at the carriage to slide with an scoring wheel. By this system, tiles with thickness higher 7 mm (only soft porcelain gres) can be also cutted, using the breaker Art.41D. For transport, the guides and all the accessories are contained in the two suitcases supplied. As an alternative, for cutting thick and particularly hard materials a angle-grinder holder carriage is available which allows sawing with a diamond blade (see page 35)

🇫🇷 KERA-CUT EXT: équipement de coupe pour carreaux grand format. Le guide en aluminium, fixé sur le carreau par des ventouses anti-taches, permet au chariot de glisser avec une roue de gravure. Grace à ce système, il est possible de couper aussi des carreaux d'une épaisseur supérieure à 7 mm (uniquement sur grès cérame tendre) avec l'aide du séparateur Art. 41D. Pour le transport, les guides et tous les accessoires sont contenus dans les deux valises fournies. Alternativement, pour couper matériaux épais et particulièrement durs, un chariot de broyage permet une coupe sciée avec une lame de diamant (voir page 35).

🇩🇪 KERA-CUT EXT: Schneid-ausrüstung für großformatige Fliesen; Die teilbare Aluminiumführung, die durch fleckenfreie Saugnapfe auf der Fliese befestigt ist, ermöglicht das Gleiten des Schlittens mit einem Scheuerrad. Mit diesem System können Fliesen mit einer Dicke von mehr als 7 mm (nur weiche Porzellansteine) mit dem Brecher Art.41D geschnitten werden. Für den Transport befinden sich die Führungen und das gesamte Zubehör in den zwei mitgelieferten Koffern. Als Alternative zum Schneiden von dicken und besonders harten Materialien steht ein Winkelschleifer-Schlitten zur Verfügung, der das Sägen mit einer Diamantklinge ermöglicht (siehe Seite 35).



🇮🇹 Carrello di scorrimento su piste indurite, con ruote rivestite in materiale plastico antiusura e doppi cuscinetti a sfere.

🇬🇧 Sliding carriage on hardened tracks, with wheels coated wear-resistant plastic material and double ball bearings.

🇫🇷 Chariot coulissant sur rails trempés, avec roues en matière plastique résistant à l'usure et double roulement à billes.

🇩🇪 Laufkatze auf gehärteten Schienen, mit Rädern aus verschleißfestem Kunststoff und doppelten Kugellagern.



🇮🇹 Fissaggio sulla piastrella con ventose antimacchia, liberamente posizionabili, adatte anche a superfici ruvide. Nuova versione con bloccaggio verticale migliorato

🇬🇧 Fixing on the tile with anti-stain suction cups, freely positioned, also suitable for rough surfaces. New version with vertical hold

🇫🇷 Fixation sur la dalle avec des ventouses anti-taches, positionnées librement, également adaptées aux surfaces rugueuses. Nouvelle version avec maintien vertical

🇩🇪 Befestigung auf der Fliese mit Anti-Fleck-Saugnapfen, frei positionierbar, auch für raue Oberflächen geeignet. Neue Version mit vertikalem Halt

🇮🇹 Le guide nella parte inferiore sono ricoperte da gomma antiscivolo e antimacchia. Versioni estensibili con tre giunti di collegamento in acciaio ad alta precisione.

🇬🇧 The guide in the lower part are covered with non-slip and stain-free rubber. Extendable versions with three high precision steel connection joints.

🇫🇷 Les guides dans la partie inférieure sont recouverts de caoutchouc antidérapant et antitache. Versions extensibles avec trois joints de raccordement en acier de haute précision.

🇩🇪 Die Führungen im unteren Teil sind mit rutschfestem und schmutzabweisendem Gummi überzogen. Ausziehbare Ausführung mit drei hochpräzisen Stahlverbindungs-muffen.



🇮🇹 Il giunto di collegamento in acciaio esagonale da 19 mm di spessore e 480 mm di lunghezza, garantisce grande rigidità e rettilinearità dei profili estrusi assemblati

🇬🇧 The 19 mm thick and 480 mm long hexagonal steel connection joint guarantees high rigidity and straightness of the assembled extruded profiles.

🇫🇷 Le joint de raccordement hexagonal en acier de 19 mm d'épaisseur et de 480 mm de longueur garantit une grande rigidité et une grande rectitude des profilés extrudés assemblés.

🇩🇪 Die 19 mm dicke und 480 mm lange sechseckige Stahlverbindungs-fuge garantiert eine hohe Steifigkeit und Geradheit der montierten Strangpressprofile.



🇮🇹 La spinta con leva a due mani permette una incisione molto profonda.

🇬🇧 The push with two-handed lever allows a very deep incision.

🇫🇷 Le levier de poussée à deux mains permet une incision profonde.

🇩🇪 Der Druck mit zweihändigem Hebel ermöglicht einen sehr tiefen Einschnitt.

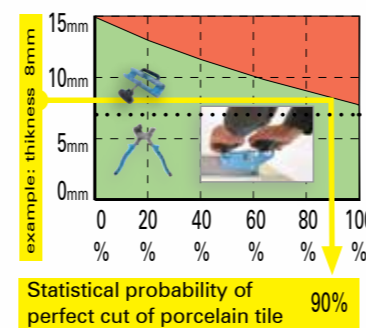

🇮🇹 Le guide nella parte inferiore sono ricoperte da gomma antiscivolo e antimacchia. Versioni estensibili con tre giunti di collegamento in acciaio ad alta precisione.

🇬🇧 The guide in the lower part are covered with non-slip and stain-free rubber. Extendable versions with three high precision steel connection joints.

🇫🇷 Les guides dans la partie inférieure sont recouverts de caoutchouc antidérapant et antitache. Versions extensibles avec trois joints de raccordement en acier de haute précision.

🇩🇪 Die Führungen im unteren Teil sind mit rutschfestem und schmutzabweisendem Gummi überzogen. Ausziehbare Ausführung mit drei hochpräzisen Stahlverbindungs-muffen.



Art.							
8AE2	332 cm 130,7 inc	234 cm 92,4 inc	0 ⇨ 7 mm 1/4 inc	7 ⇨ (30 mm vetro/glass)	14,2 Kg	2 pz. 17,5 Kg.	184 x 18 x 16 cm. + 52 x 42 x 14 cm.
8AE2+8AEP2	382 cm 150,4 inc	270 cm 106,3 inc	0 ⇨ 7 mm 1/4 inc	7 ⇨ (30 mm vetro/glass)	18,2 Kg	3 pz. 21,5 Kg.	184x18x16 + 73x25x16 + 52 x 42 x 14 cm.



## KERA-CUT EXT



Art. 8AE2 cm.332

Accessori e ricambi      Accessoires and spare parts



Art. 8AEP2 cm.50

Art. 38F5

🇮🇹 Art. 38F5 Fissaggio al piano con supporti girevoli, per tagli ripetitivi; ruotando, la guida si solleva fino a 21mm, per rimuovere rapidamente la piastrella.

🇬🇧 Art. 38F5 Fixing to the working table with swivel supports, for repetitive cuts; by turning, the guide raises up to 21mm and allows a quickly tile removing.

🇫🇷 Art. 38F5 Fixation au plan de travail avec des supports pivotants, pour coupes répétitives; tournant, le guide se soulève jusqu'à 21mm, pour enlever rapidement la tuile.

🇩🇪 Art. 38F5 Arbeitstischbefestigung mit drehbaren Halterungen für wiederholtes Brechen; durch die Drehbewegung, hebt sich die Schiene bis zu 21mm hoch um die Fliese leicht entfernen zu können.

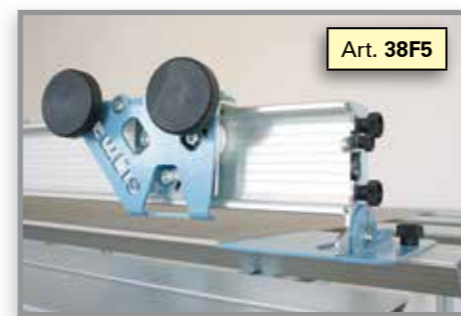
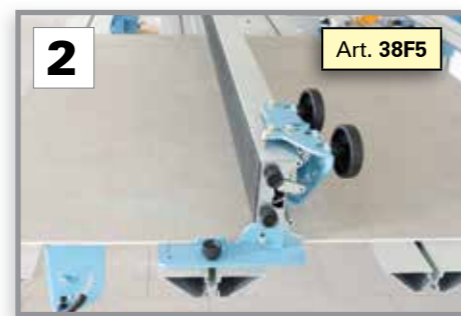
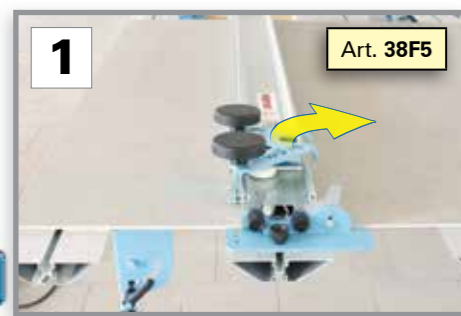

Art.	Descrizione	Description	
8AE2	TAGLIA PIASTRELLE completa, versione estensibile KERA-CUT EXT cm. 332	TILE CUTTER complete, extensible version KERA-CUT EXT cm. 332	1
	Accessori a richiesta	Accessoires on request	
8AEP2	Prolunga per 8AE cm.50	Extension for 8AE cm.50	1
38F5	Coppia supporti girevoli	Couple rotating supports	1
<b>NEW</b>	SEPARATORE universale per piastrelle preincise	Universal SEPARATOR for pre-scored tiles	
41E	0>15mm disp.dal 11/2020	0>15mm available from 11/2020	1
41D	0>30mm	0>30mm	1
	Ricambi versione EXT	EXT version Spare parts	
51C2	Ventosa alluminio per KERA-CUT Ø120 (40Kg.)	KERA-CUT aluminum suction cup Ø120 (40Kg.)	1
14G	Rotella di incisione Ø13mm, di serie per 8AE2 8C2 8D2 8E2 8G2 8CE 8DE	Ø13 mm. scoring wheel, standard for 8AE2 8B2 8C2 8D2 8E2 8G2 8CE 8DE	20
51F	Gomma per ventosa 51C2 Ø120	Rubber plate for suction cup 51C2 Ø120	1
43K	Valigia in tela imbottita per guide KERA-CUT 171 cm	Canvas padded case for KERA-CUT guides 171 cm	1
41C	pinza KERA-CUT per spacco	Nipper KERA-CUT for breaking	1
41C2	piede nylon per pinza 41C	nylon foot for nipper 41C	1
	Ricambi vecchie versioni	old version Spare parts	
14K	Rotella di incisione 19mm, di serie per: 8C 8E.	Ø19 mm. scoring wheel standard for: 8C 8E.	1
	Gruppo KERA-FLEX INX con disco 75B predisposto per smerigliatrice standard	KERA-FLEX INX group with blade 75B ready for standard grinder	
38F13D	attacco filetto M14	spindle thread M14	1
38F13PD	filetto 5/8-11 UNC x USA-CAN	thread 5/8-11 UNC x USA-CAN	1
38C	Guida scorrimento inx 161 cm.	Inx sliding guide 161 cm.	1
38D	Guida scorrimento inx 201 cm.	Inx sliding guide 201 cm.	1
38E	Guida scorrimento inx 331 cm.	Inx sliding guide 331 cm.	1



Art. 41D

## KERA-FLEX EXT



Art. 38F11D

Art. 38F11PD

**NEW**

Art. 87E4



1



2

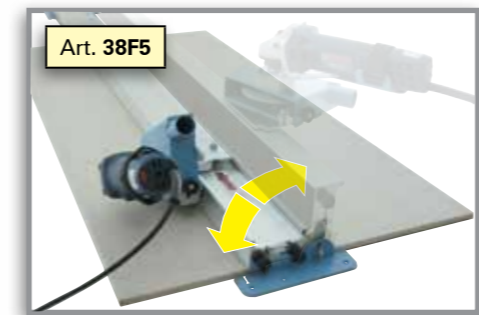

Art. 38F5



1



2



3

Art.	Descrizione	Description	
38F11D	Gruppo KERA-FLEX EXT con disco 75B predisposto per smerigliatrice standard, attacco filetto M14	KERA-FLEX EXT group with blade 75B ready for standard grinder, spindle thread M14	1
38F11PD	Gruppo KERA-FLEX EXT con disco 75B predisposto per smerigliatrice attacco filetto 5/8-11 UNC per U.S.A. Canada	KERA-FLEX EXT group with blade 75B ready for grinder, spindle thread 5/8-11 UNC, for U.S.A. Canada	1
	Accessori a richiesta	Accessoires on request	
87E4	Waterkit sistema di raffreddamento per l'utensile diamantato con nebulizzazione d'acqua 10lt, garantisce maggior velocità e finitura. Compatibile anche per versioni precedenti. Necessario l'utilizzo di smerigliatrice a batteria.	Waterkit cooling system for the diamond tool with water spray (10lt), guarantees better speed and finish. Also compatible for previous versions. The use of a cordless grinder is necessary.	1
458	fissaggio extra per Waterkit 87E4	extra fixing for Waterkit 87E4	1
75B	Disco diamantato Ø 115mm foro 22,2, spes.1,3 mm per materiali da 5 a 25 mm	Diamond disc Ø 115 mm hole 22,2 mm, thick 1,3 mm, tile 5 to 25 mm	1
75D	Disco diamantato Ø 125mm foro 22,2 mm, spes.1,4 mm per materiali da 5 a 30 mm	Diamond disc Ø 125 mm hole 22,2 mm, thick 1,4 mm, tile 5 to 30 mm	1
75C3	Disco diamantato Ø 115mm foro 22,2 mm, spes.1,1 mm per materiali da 3 a 12 mm	Diamond disc Ø 115 mm hole 22,2 mm, thick 1,1 mm, tile 3 to 12 mm	1

🇮🇹 Il kera-flex, montato sulla guida kera-cut permette il taglio segato, con disco diamantato fino spessori di 30 mm.

🇬🇧 The kera-flex, mounted on the kera-cut guide, allows cutting with a diamond blade up to 30 mm thick.

🇫🇷 Le Kera-flex, monté sur le guide kera-cut, permet de couper avec une lame de diamant jusqu'à 30 mm d'épaisseur.

🇩🇪 Die Kera-flex, die auf der Kera-Cut-Führung montiert ist, ermöglicht das Schneiden mit einer bis zu 30 mm dicken Diamantklinge.

🇮🇹 Facile regolazione del fermo di profondità

🇬🇧 Easy adjustment of the depth stop

🇫🇷 Réglage facile de la butée de profondeur

🇩🇪 Einfache Einstellung des Tiefenanschlags



Art.63E

Art.63F



**patented**



**Banco da Lavoro** smontabile e modulare, particolarmente adatto come appoggio per lavorare lastre e piastrelle ceramiche. Grazie alla sua struttura in alluminio, leggera e robusta, garantisce un' ottimo sostegno per le piastrelle di grande formato. Al banco da Lavoro è possibile fissare facilmente svariate attrezzature, come la guida di taglio Kera-Cut, kit fissaggio a banco per Simple Bevel e Jolly Edge, ecc.. Sono disponibili accessori come: morsetti (art. 400) per serraggio, ganci (art. 402) per sostenere la guida di taglio Kera-Cut, distanziali (art.409) di rialzo piastrella per effettuare tagli trasversali con un disco diamantato, ecc...

Demountable and modular workbench, particularly suitable as a support for working slabs and ceramic tiles. Thanks to its aluminium structure, light and sturdy, it guarantees an excellent support for large format tiles. At the Workbench you can easily attach various equipment, such as Kera-Cut cutting guide, table fixing kit for Simple Bevel and Jolly Edge, etc.. Accessories such as: clamps for tile (item 400), hooks for support the Kera-Cut cutting guide (item 402), tile riser spacers to make transversal cuts with a diamond blade (art.409) etc ...

Table de travail amovible et modulaire, particulièrement adaptée comme support pour travail sur dalles et carreaux en céramique. Grâce à sa structure en aluminium, légère et robuste, garantit un excellent soutien pour les dalles de grand format. Divers équipements peuvent être fixés sur la table: guide pour coupe Kera Cut, kit de fixation pour Simple Bevel et Jolly Edge, ..etc. Autres accessoires sont disponibles: pinces pour la fixation (art.400), crochets à soutenir la guide Kera Cut (art.402), entretoises pour élever les carreaux pour coupes transversales avec disque de diamant (art.409) etc..

Zerlegbare und modulare Werkbank, besonders geeignet als Träger für die Bearbeitung von Platten und keramischen Fliesen. Dank seiner leichten und robusten Aluminiumstruktur garantiert er eine hervorragende Unterstützung für großformatige Fliesen. An der Werkbank können Sie verschiedene Geräte, wie zB die Kera-Cut Schneidführung, das Tischmontageset für Simple Bevel und Jolly Edge usw. einfach befestigen. Zubehör ist verfügbar wie: Klemmen zum Klemmen (Artikel 400), Haken zur Unterstützung der Kera-Cut-Schnittführung (Artikel 402), Fliese Riser Abstandhalter zu transversalen Schnitte mit einer Diamantscheibe (art.409) etc ...



sigmaitalia

Art.										
63E	180 cm 70,8 inc	96 cm 37,8 inc	82 cm 32 inc	200 Kg.	22 Kg.	1 pz. 24 Kg.	192 x 45 x 20 cm.	10 pz.		
63F	180 cm 70,8 inc	151,5 cm 59,6 inc	82 cm 32 inc	200 Kg.	29 Kg.	1 pz. 31 Kg.	192 x 45 x 20 cm.	10 pz.		

**I Banchi da Lavoro** sono collegabili fra loro per ottenere un piano di appoggio unico lungo 360cm.

Workbenches can be connected to each other get a single worktop 360cm long.

Les tables peuvent être connectés les uns aux autres; on peut obtenir un plan de soutien long 360 cm.

Werkbänke können miteinander verbunden werden, um eine einzige 360 cm lange Auflagefläche zu erhalten.

Con i suoi piani facilmente posizionabili è possibile creare zone vuote, per effettuare lavorazioni che attraversano la piastrella, come fori e tasche. E' inoltre possibile aggiungere o spostare i piani per creare una superficie di lavoro continua.

With its easily positioned aluminium planks you can create empty areas to allow workings that pass through the tile, such as holes and pockets. It is also possible to add or move planks to create a continuous worktop.

Avec ses plans de soutien facilement positionnables, il est possible de créer des zones vides, pour travailler sur des carreaux tels que des trous et des poches. On peut également ajouter ou déplacer les plans pour créer une surface de travail continue.

Mit seinen kleinen, leicht zu positionierenden Oberflächen ist es möglich, leere Bereiche zu schaffen, um Arbeiten durchzuführen, die durch die Fliese gehen, wie Löcher und Taschen. Es ist auch möglich, kleine Ebenen hinzuzufügen oder zu verschieben, um eine durchgehende Arbeitsfläche zu schaffen.

Per un facile trasporto, è sufficiente piegare le gambe, minimizzando l'ingombro, oppure è possibile smontare completamente il banco in pochi minuti riducendo l'ingombro in una scatola di cartone.

For easy transport, it is sufficient to bend the legs, minimize the overall dimensions, or the workbench can be completely dismantled in a few minutes reducing the space in a carton box.

Pour une manipulation facile, il suffit de plier les jambes pour minimiser l'encombrement; ou la table peut être complètement démantelée en quelques minutes, et réduire l'encombrement dans une boîte en carton.

Für einen einfachen Transport reicht es aus, die Beine zu biegen, die Gesamtmaße zu minimieren oder die Bank innerhalb weniger Minuten vollständig zu demontieren, wodurch die Gesamtmaße in einer Pappschachtel reduziert werden.





sigmaitalia

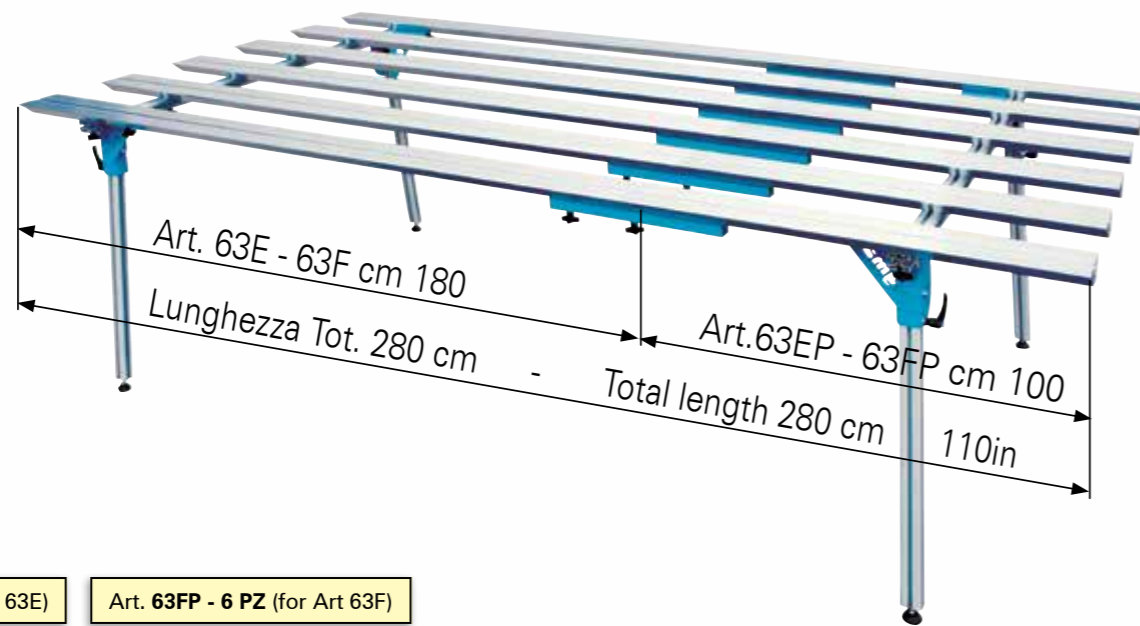

Art. 63EP - 4 PZ (for Art 63E)

Art. 63FP - 6 PZ (for Art 63F)

**I** Prolunga per banco da lavoro permette di allungare la superficie di 100 cm, arrivando ad una lunghezza totale di 280 cm; accoppiamento di precisione e rapidità di montaggio.

**U** Extension for Workbench, allows to lengthen the surface of 100 cm, reaching a total length of 280 cm; precision and quick assembly.

**L** L'extension pour la table de travail permet d'allonger de 100 cm la surface de travail, arrivant à une longueur totale de 280 cm; raccord de précision et montage rapide.

**E** Erweiterung für Workbench, ermöglicht eine Verlängerung der Oberfläche um 100 cm bis zu einer Gesamtlänge von 280 cm; Präzision und schnelle Montage.

Art. 409



**I** Distanziali alzano la piastrella permettendo il taglio con disco trasversale della stessa, senza danneggiare il Banco da lavoro. Non vanno utilizzati per il taglio ad incisione ( 50 pz per box ).

**U** The Spacers raise the tile allowing cutting with the disk transverse it without damaging the workbench. Do not use for scoring cutting ( 50 pz for any box ).

**L** Les Entretoises soulèvent la tuile, permettant de couper avec le disque transversal de la même, sans endommager la table de travail. Ne pas utiliser pour coupes de gravure (pack de 50 pièces).

**E** Die Abstandshlster heben die Fliese an und ermöglichen das Schneiden mit der Scheibe Quer es ohne Beschädigung der Werkbank. Nicht zum gravieren verwenden ( 50 Stück pro karton ).



Art. 63FP - 6 PZ (for Art 63F)



Art. 63EP - 4 PZ (for Art 63E)

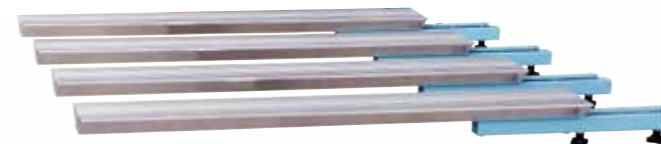

Art. 400



**I** I Morsetti per il Banco da lavoro sono indispensabili per fermare correttamente la piastrella o lastra durante l'esecuzione di lavorazioni.

**U** The clamps for the workbench are indispensable to fix the tile correctly during processing.

**L** Les serre-joints pour la Table de Travail sont essentielles pour maintenir correctement le carreau ou dalle en place pendant le traitement.

**E** Die Werkbankklammern sind wichtig, um die fliese oder platte während der Bearbeitung ordnungsgemäß zu stoppen.

Art. 402



**I** I Ganci per il Banco da lavoro sostengono e proteggono la guida di taglio Kera-Cut da urti accidentali.

**U** The hooks for the workbench support and protect the Kera-Cut cutting guide from accidental impacts.

**L** Les crochets pour la Table de Travail soutiennent et protègent la guide de coupe Kera Cut, contre les impacts accidentels.

**E** Die Haken für die Werkbank stützen und schützen die Kera-Cut Schneideführung vor versehentlichen Stößen.

Art.	Descrizione	Description	
63E	Banco di Lavoro 180x100 in alluminio, completo di 4 pianetti e staffa per unire 2 banchi	Alluminium Workbench 180x100 complete with 4 alluminium planks and bracket to join 2 benches	1
63F	Banco di Lavoro 180x150 in alluminio, completo di 6 pianetti e staffa per unire 2 banchi	Alluminium Workbench 180x150 complete with 6 alluminium planks and bracket to join 2 benches	1
	Accessori a richiesta	Accessoires on request	
63EP	Prolunga da 100 cm per Banco da lavoro 63E (4 barre)	Extension 100 cm for Workbench 63E (4 bars)	1
63FP	Prolunga da 100 cm per Banco da lavoro 63F (6 barre)	Extension 100 cm for Workbench 63F (6 bars)	1
400	Kit 2 Morsetti	Kit of 2 clamps	1
402	Kit 2 Ganci per sostegno guida di taglio Kera Cut	Kit of 2 hooks for support the Kera Cut cutting guide	1
409	Kit 50 distanziali per piano	Kit of 50 spacers for raise the worktop	1
103853	Pianetto aggiuntivo 180x13 cm.	Additional alluminium planks 180x13 cm.	1
439	ulteriore staffa per unire 2 banchi di lavoro	bracket to join 2 Workbenches	1





**Italy** PER LA MOVIMENTAZIONE E LA POSA DI GRANDI LASTRE

**UK** FOR HANDLING AND LAYING OF LARGE FORMAT TILES

**France** POUR LA MANIPULATION ET LA POSE DE GRANDES DALLES

**Germany** ZUM BEWEGEN UND VERLEGEN VON GROSSEN PLATTEN

» KERA-LIFT » attrezzatura con ventose per il sollevamento, la movimentazione e la posa di grandi piastrelle, liberamente modificabile senza l'uso di utensili, è composta da guide scorrevoli fra loro per adattarsi a qualsiasi forma della lastra. Le ventose possono scorrere lungo il profilo per adattarsi a qualsiasi esigenza. Tutti i modelli sono certificati CE.

» KERA-LIFT » equipment with suction cups for lifting, handling and laying of large tiles, freely modifiable without the use of tools, is composed by guides sliding between them to adapt to any shape of the slab. The suction cups can slide along the profile to adapt to any need. All models are CE certified.

» KERA-LIFT » équipement avec des ventouses pour le levage, la manipulation et l'installation de grandes tuiles, librement modifiables sans l'utilisation d'outils, est composé de rails de glissement pour s'adapter à n'importe quelle forme de la plaque. Les ventouses peuvent glisser le long du profil pour s'adapter à tous les besoins. Tous les modèles sont certifiés CE.

» KERA-LIFT » Vorkehrung mit Saugnäpfen zum Heben, Bewegen und Verlegen von großen Platten; durch die zwei untereinander verschiebbaren Führungen die ohne eglichem Werkzeug verstellt werden können, kann diese Vorkehrung jeder beliebigen Plattenform angepasst werden. Die Saugnäpfe können entlang des Profils gleiten, um sich an jedes Bedürfnis anzupassen. Alle Modelle sind CE-zertifiziert.

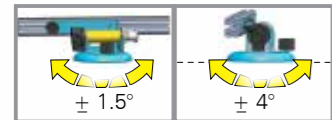

Ventose Basculanti  
Tilting suction cups



Traversi smontabili per lastre strette  
Dismontable for small slabs



**KERA-LIFT Art. 1A5**  
max: 340 x 160

x 6 pz  
Ventose a pompa Ø150 con Vuotometro  
Pump suction cups Ø150 with Vacuum indicator

x 6 pz  
Protezione delle ventose Ø150  
Protection of Ø150 suction cups

x 4 pz  
Sicure Anticaduta  
Safety fall brackets

Art.							
1A4	340 cm max - 195 cm min 134 inc max - 76 inc min	160 cm max - 40 cm min 63 inc max - 16 inc min	100 Kg. Max.	CE	18,7 Kg.	1 pz. 20,1 Kg	202 x 36 x 38 cm
1A5	340 cm max - 195 cm min 134 inc max - 76 inc min	160 cm max - 40 cm min 63 inc max - 16 inc min	150 Kg. Max.	CE	20,9 Kg.	1 pz. 22,2 Kg	202 x 36 x 38 cm
1D2	340 cm max - 195 cm min 134 inc max - 76 inc min	80 cm max - 20 cm min 31 inc max - 8 inc min	40 Kg. Max.	CE	6,0 Kg.	1 pz. 7,0 Kg	202 x 29 x 23 cm

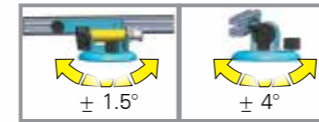

Ventose Basculanti  
Tilting suction cups

103822  
103824  
051P4  
051D2



**KERA-LIFT Art. 1A4**  
max: 340 x 160

x 2 pz  
Ventosa a pompa Ø150  
Pump Suction Cups Ø150

x 6 pz  
Ventose manuali Ø120  
Manual suction cups Ø120

x 4 pz  
Sicure Anticaduta  
Safety fall brackets



Traversi smontabili per lastre strette  
Dismontable for small slabs



Esempi di configurazioni ottenibili con i componenti forniti con 1A4 1A5

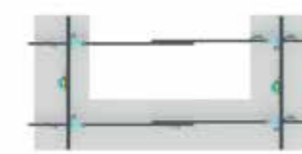

Des exemples de configurations pouvant être obtenus avec les composants fournis avec les 1A4 1A5

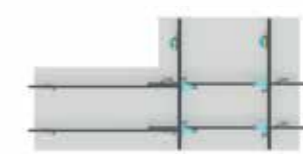

Examples of configurations obtainable with components supplied with the 1A4 1A5



Beispiele der möglichen Konfigurationen die mit dem Zubehör 1A4 1A5, ausgeführt werden können.



**KERA-LIFT Art. 1D2**  
max: 340 x 100

x 4 pz  
Ventose manuali Ø120  
Manual suction cups Ø120

x 2 pz  
Sicure Anticaduta  
Safety fall brackets

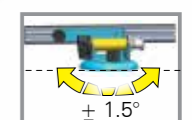

Ventose Basculanti  
Tilting suction cups





CE

Art. 421



(Kit Carrello non compatibile con le versioni precedenti del Kera-Lift)  
(Carriage Kit is not compatible with the old version of Kera-Lift)

The Carriage Kit Art. 421 allows the movement of the frame in a easy and safe way. Thanks to the rotating wheel it is possible to run ruote with curves. The tresles allow the perfect support of the slab even during the applying of the glue, there are two safe Anti-fall brackets coated in rubber.

Le Kit Chariot Art. 421 permet de déplacer le cadre facilement et en toute sécurité. Grâce à la roue pivotante, il vous permet de vous déplacer dans les courbes. Les supports permettent un support parfait de la dalle, même lors de l'application de la colle; il y a deux dispositifs antichutes recouverts de caoutchouc.

Das Trolley-Kit Art. 421 ermöglicht die Bewegung des Rahmens auf eine Art und Weise einfach und sicher. Dank des drehbaren Rades können Bahnen mit Kurven gefahren werden. Die Böcke ermöglichen die perfekte Unterstützung der Platte, auch wenn der Leim verlegt wird. Es gibt zwei sichere, mit Gummi beschichtete Anti-Fall-Materialien.

Il Kit Carrello Art. 421 permette la movimentazione del telaio in maniera facile e sicura. Grazie alla ruota girevole è possibile l'esecuzione di percorsi con curve. I cavalletti permettono il perfetto sostegno della lastra anche in fase di stesura della colla, sono presenti due sicure Anti-caduta rivestite in gomma.

Art. 424



(Kit Maniglie 100% compatibile con le versioni precedenti del Kera-Lift)  
(Handles Kit is 100% compatible with the old version of Kera-Lift)

Le Maniglie rendono ancora più comodo il sollevamento della lastra, possono essere posizionate a piacimento.

Handles make lifting the slab more comfortable, and can be positioned at will.

Les poignées rendent le levage de la dalle encore plus confortable, et peuvent être positionnées à volonté.

Die Griffe machen das Anheben der Platte noch komfortabler, kann beliebig positioniert werden.

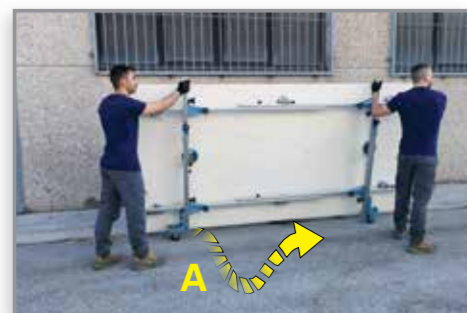
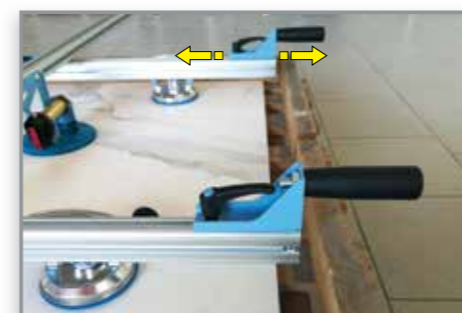

Durante il trasporto, la Persona "A" può direzionare il telaio a piacimento.

During transport, the person "A" can direct the frame in any direction.

Pendant la manipulation, la personne "A" peut diriger le cadre dans n'importe quelle direction.

Während des Transports kann die Person "A" den Rahmen nach Belieben fahren.



Ruota Anti-segno girevole di 280° permette la movimentazione con curve del telaio, bloccabile in posizione rettilinea.

Non-marking wheel, rotatable at 280°; lockable in straight position.

Roue pivotante de 280°, non marquante; verrouillable en position droite.

Anti-Zeichen-Raddrehung 280° ermöglicht die Bewegung mit Kurven des Rahmens, das Rad ist arretierbar in gerade Position.



Le sicure Anti-caduta rivestite in gomma, sono rimovibili per le operazioni di posa.

Anti-fall safety devices, rubber covered, can be removed for laying operations.

Dispositifs de sécurité antichute, recouverts de caoutchouc, sont amovibles pour les opérations de pose.

Die gummierten Stützen sind für Verlegearbeiten abnehmbar.



Art.	Descrizione	Description	
1D2	Sollevatore KERA-LIFT 340 cm. Completo con 4 vent. 51D2 + 2 sicure anticaduta	Lift KERA-LIFT 340 cm. Complete with 4 sukers 51D2 + 2 fall protection safety	1
1A4	Sollevatore KERA-LIFT 340x160 cm. Completo con 6 vent. 51D2+2 vent. 51P4 + 4 sicure anticaduta	Lift KERA-LIFT 340x160 cm. Complete with 6 suk. 51D2 + 2 suk. 51P4 + 4 fall protection safety	1
1A5	Sollevatore KERA-LIFT 340x160 cm. completo con 6 vent. 51P3 + 4 sicure anticaduta	Lift KERA-LIFT 340x160 cm. Complete with 6 sukers 51P3 + 4 fall protection safety	1
421	KIT CARRELLO completo di 2 ruote con supporto lastra+ 2 piedi apribili	CARRIAGE KIT Complete with: 2 wheels with slab support + 2 opening feet	1
424	KIT MANIGLIE completo di 4 pz	HANDLES KIT complete with 4 pz	1
Ricambi modelli 2019		2019 Spare parts	
51D2	Ventosa a leva Ø120 mm per montaggio su longerone art 1A4	Lever Suction Cup Ø120 mm for mounting on long bar 1A4	1
51P4	Ventosa a pompa per KERA-LIFT 1A4 Ø150 mm. Portata max 90kg (45kg a norme CE)	Pump Suction Cup Ø150 mm. for KERA-LIFT 1A4 Capacity max 90kg (45 kg to CE rules)	1
51P3	Ventosa a pompa con vuotometro per KERA-LIFT 1A5 Ø150 mm. Portata max 90kg (45kg a norme CE)	Pump Suction Cup Ø150 mm. with vacuum gauge for KERA-LIFT 1A5 Capacity max 90kg (45 kg to CE rules)	1
10518	Protezione per la gomma delle ventose Ø150 mm	Protection for the rubber of Ø150 mm suction cups	1
51F	Gomma per ventosa Ø120 mm (tutti i modelli)	Rubber for Suction Cup Ø120 mm	1
103822	traverso 97 cm	97 cm cross bar	1
103824	traverso 157 cm	157 cm cross bar	1
10026	vuotometro per 51P3	vacuum gauge for 51P3	1
51F1	filtro Ø12x4 per 51P1/2/3/4	felt filtre Ø12x4 for 51P1/51P2/51P3/51P4	1
Ricambi vecchi modelli 2013-2018		Old models 2013-2018 Spare parts	
51D	Ventosa a leva Ø120 mm per montaggio su longerone	Lever Suction Cup Ø120 mm for mounting on long bar	1
51E	Ventosa a leva Ø120 mm per montaggio su traverso alto	Lever Suction Cup Ø120 mm for mounting on upper cross bar	1
51P2	Ventosa a pompa Ø150 mm	Pump Suction Cup Ø150 mm	1
297	Sicura anticaduta	Safety fall bracket	1

Art. 10518

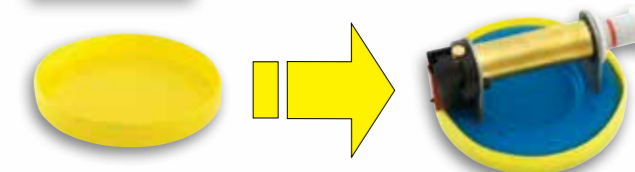

Protezione per la gomma delle ventose Ø150. Protection for the rubber of Ø150 suction cups.



**JOLLY EDGE** Scivolando in appoggio sul bordo della piastrella / lastra (gres, marmo, granito, ecc.), garantisce l'uniformità del taglio / smusso su tutta la lunghezza dello spigolo lavorato, copiando esattamente le curve fisiologiche della lastra; cosa che non sarebbe possibile con una fresa guidata da una guida rigida. Può lavorare, in una unica passata, piastrelle con spessore 5 < 20mm e dimensione da 30 cm a infinito. Nella configurazione con disco diamantato, permette l'esecuzione di jolly a qualsiasi angolazione compresa fra 40° e 50°. Nella configurazione con mola diamantata, permette l'esecuzione di smussi rotondi (BULL) con raggio 6 - 8 - 10mm. Predisposto per smerigliatrici 700 - 1400 W, completo di disco art.75B, capacità disco max.125mm.

**JOLLY EDGE** Sliding resting on the edge of the tile / slab (stoneware, marble, granite, etc.), ensures the uniformity of the miter along the entire length of the edge worked, copying exactly the physiological shapes of the slab; which would not be possible with a cutter guided by a rigid guide. It can work in a single pass, tiles with thickness 5 < 20mm and size from 30 cm to infinity. In the configuration with diamond blade, it allows the mitering at any angle from 40° to 50°. In the configuration with diamond grinding wheel, it allows the execution of Bullnose with radius 6 - 8 - 10mm. Group ready for grinder 700 - 1400W. complete with blade disc art.75B, disk capacity max. 5"

**JOLLY EDGE** En glissant reposant sur le bord de la tuile / dalle (gres, marble, granit, etc.), assure l'homogénéité du chanfrein sur toute la longueur du bord travaillé, copiant exactement les courbes physiologiques de la dalle; qui ne serait pas possible avec un dispositif de coupe guidé par un guide rigide. Il peut travailler en un seul passage, les carreaux avec une épaisseur de 5 < 20mm et la taille de 30 cm à l'infini. Dans la configuration avec disque de diamant, il permet aux boîtes de biseaux à un angle quelconque compris entre 40° et 50°. Dans la configuration avec la roue de diamant, il permet l'exécution de chanfreins ronds (BULL) avec rayon 6 - 8 - 10mm. Préparé pour les broyeurs 700 - 1400 W, complet avec disque art.75B, capacité maxi disque 125mm.

**JOLLY EDGE** Die Maschine gleitet der Fliesenkante/Platte entlang (Feinsteinzeug, Marmor, Granit, usw.) und sorgt für einen regelmäßigen Schnitt/Schliff entlang der gesamten Länge der verarbeiteten Kante; dabei wird die natürliche Linienführung der Platte wiedergegeben was mit einem Fräser der durch eine steife Führung geführt wird, sonst nicht möglich wäre. Es können mit einem einzigen Durchgang, Fliesen mit einer Dicke von 5 < 20mm und einer Größe ab 30 cm bis endlos verarbeitet werden. In der Konfiguration mit Diamantscheibe, ermöglicht es, die Schrägen Gerichte in jedem beliebigen Winkel zwischen 40° und 50°. In der Konfiguration mit Diamantschleifscheibe, ermöglicht es die Ausführung von runden Fasen (BULL) mit einem Radius von 6 - 8 - 10 mm. Vorbereitet für Schleifmaschinen 700 - 1400 W, komplett mit disc art. 75B, max plattenkapazität 125mm.



**La macchina 37A2D-37A2PD con il kit 37C, va fissata ad un banco ed è consigliata per lavorare piastrelle strette e lunghe, come piastrelle per battiscopa, ecc.**

**The machine 37A2D-37A2PD with the kit 37C, to be fixed on a table, and recommended for long and narrow tile working, like skirting tiles.**

**La machine 37A2D-37A2PD avec le kit 37C, doit être fixé à une table et est recommandé pour les travaux de carrelage long et étroit, comme en contournant tuiles, etc.**

**Die Maschine 37A2D-37A2PD mit Satz 37C, muss auf einer Werkbank befestigt werden und eignet sich um schmale und lange Fliesen zu verarbeiten wie z.B. Sockel Leisten, usw.**

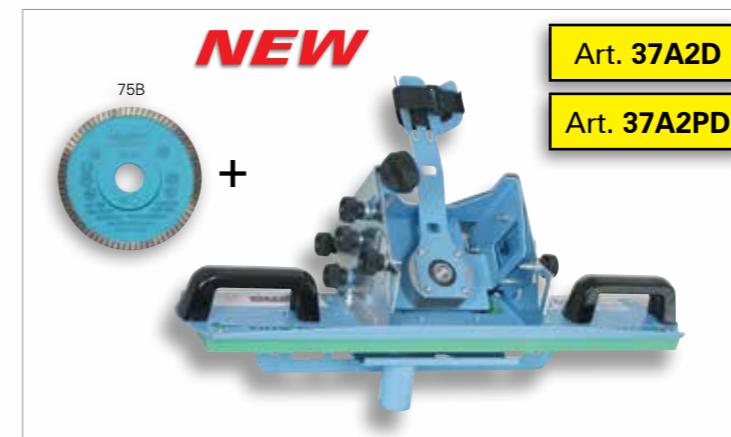

Art.	Descrizione	Description	
37A2D NEW	JOLLY-EDGE con attacco universale M14, con disco 75B	JOLLY-EDGE with universal spindle thread M14, with diamond disc 75B	1
37A2PD NEW	JOLLY-EDGE con attacco universale 5/8-11 UNC; per U.S.A. - Canada con disco 75B	JOLLY-EDGE with universal spindle thread 5/8-11 UNC; for U.S.A. - Canada with diamond disc 75B	1
87E4 NEW	Waterkit sistema di raffreddamento per l'utensile diamantato con nebulizzazione d'acqua (10lt), garantisce maggior velocità e finitura. Compatibile anche per versioni precedenti. Necessario l'utilizzo di smerigliatrice a batteria.	Waterkit cooling system for the diamond tool with water spray (10lt), guarantees better speed and finish. Also compatible for previous versions. The use of a cordless grinder is necessary.	1
458 NEW	fissaggio extra per Waterkit 87E4	extra fixing for Waterkit 87E4	1
37C	Kit fissaggio al banco per smussatura battiscopa per art. 37A1-37A2	Table Fixing kit for edge skirting. For art. 37A1-37A2	1
	Disco diamantato professionale Ø 115 foro 22,2 mm	Diamond disc Ø 115 mm bore 22,2 mm,	
75XR1	spessore 1,4 mm per materiali da 8 a 20 mm	thick 1,4 mm for materials from 8 to 20 mm thick	10
75B	spessore 1,4 mm per materiali da 8 a 20 mm	thick 1,4 mm for materials from 8 to 20 mm thick	10
75C3	spessore 1,1 mm per materiali da 3 a 12 mm	thick 1,1 mm for materials from 3 to 12 mm thick	10
75C	spessore 1,5 mm per materiali da 3 a 12 mm	thick 1,5 mm for materials from 3 to 12 mm thick	10
72L	Mola diamantata professionale Ø 115 raggio 8, 6000 rpm durata 1000 mt. foro 22,2 mm	Professional diamond grinding cup Ø115 radius 8, 6000 rpm duration 1000 mt. hole 22,2	1
	Mola diamantata Vacuum durata 300 mt. su gres porcellanato, foro 22,2 mm	Vacuum diamond grinding cup, duration 300mt (porcelain gres), hole 22,2	
072V06S	Ø 115 raggio 6, 6000 rpm	Ø115 radius 6, 6000 rpm	1
072V08S	Ø 115 raggio 8, 6000 rpm	Ø115 radius 8, 6000 rpm	1
072V10S	Ø 115 raggio 10, 6000 rpm	Ø115 radius 10, 6000 rpm	1
pag.45/49	Accessori per finitura toro	Accessoires for Bullnose finishing	

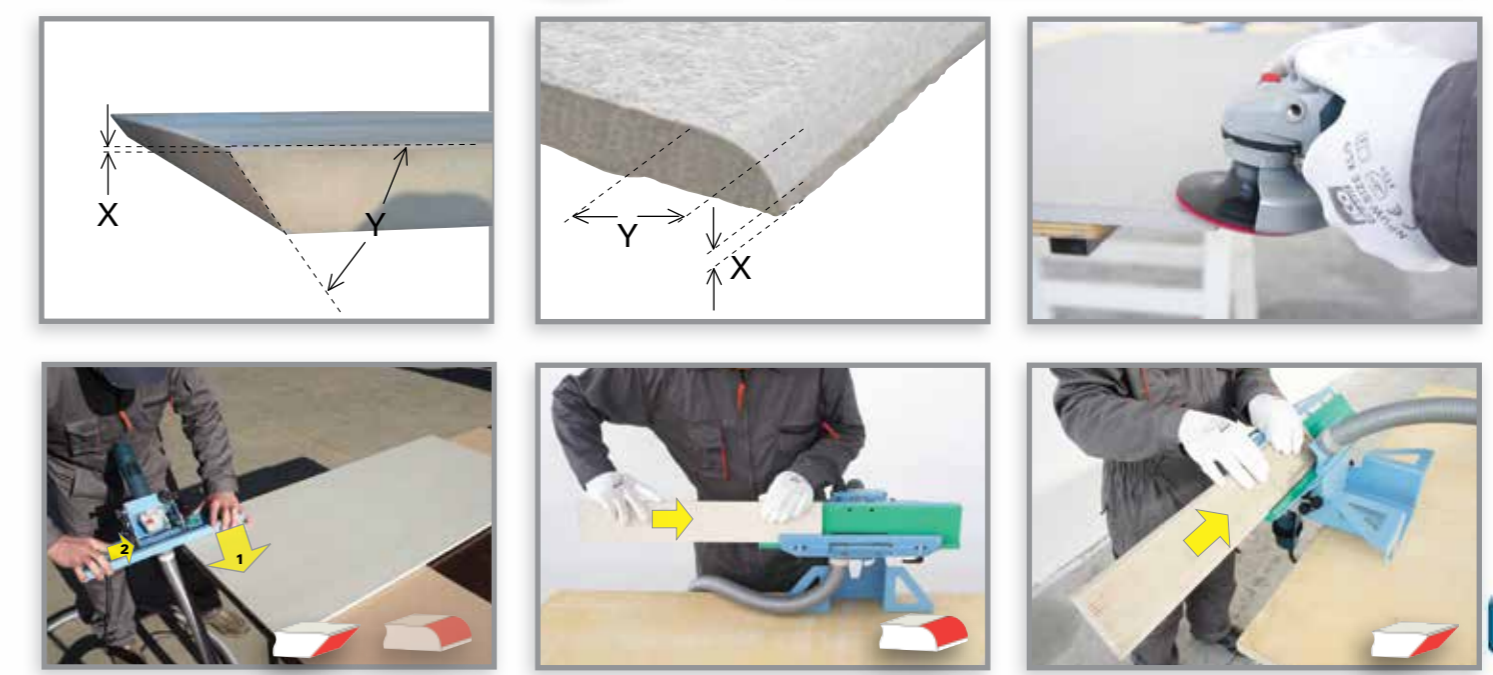

Art.				
37A2D - 37A2PD	4,5 Kg.	1 pz.	5,8 Kg.	52 x 38 x 22 cm.



**Per biselli precisi**  
**For accurate bevel**

**Pour biseaux de précision**  
**Für präzise Fasen**

# SIMPLE - BEVEL

**sigma**  
di Ambrogiani

**Per lavorazione spigoli e bordi laterali**

**For edges working**

**Pour le traitement des arêtes et des bords latéraux**

**Um Kanten und seitliche Ränder zu verarbeiten**

**SIMPLE BEVEL** Macchina per smussi di precisione su piastrelle e lastre in gres porcellanato, marmo, granito, vetro. Scivolando in appoggio sul bordo della piastrella, garantisce la uniformità dello smusso su tutta la lunghezza dello spigolo lavorato, copiando esattamente le curve fisiologiche della lastra; cosa che non sarebbe possibile con una fresa guidata da una guida rigida. Smusso da 0<12 mm (0<6 mm gres porcellanato). Regolabile a qualsiasi angolazione da 22° a 90°. Il TORO si ottiene con più passaggi ad angolazioni diverse. (r.6 nativo). Permette la rifinitura del bordo laterale della piastrella (max.30mm).

**SIMPLE BEVEL** Precision chamfer machine on gres porcelain tiles or Marble, Granite, Glass. Sliding resting on the edge of the tile, ensures the uniformity of the bevel along the entire length of the edge worked, following exactly the physiological curves of the slab; which would not be possible with a cutter guided by a rigid guide. Bevel from 0 to 12 mm (from 0 to 6mm on porcelain gres) Adjustable to any angle from 22° to 90°. The BULL is obtained with multiple passes at different angles. (r. 6 native). Allows finishing of the lateral edge of the tile (max.30mm)..

**SIMPLE BEVEL** Machine pour biseaux de précision sur carreaux en gres porcelaine, granite, marbre, verre. En glissant reposant sur le bord de la tuile, assure l'homogénéité du chanfrein sur toute la longueur du bord travaillé, copiant exactement les courbes physiologiques de la dalle; qui ne serait pas possible avec un dispositif de coupe guidé par un guide rigide. Biseau de 0 à 12 mm (de 0 à 6 mm sur porcelaine). Ajustable à n'importe quel angle de 22° à 90°. Le "TORO" est réalisé avec passages multiples à des angles différents. r. 6 native). Permet la finition du bord latéral de la tuile (max.30mm)..

**SIMPLE BEVEL** Maschine um präzise Kantenprofile an Fliesen und Platten aus Feinsteinzeug, Marmor, Granit und Glas auszuführen. Die Maschine gleitet entlang der Fliesenkante und sorgt für einen regelmäßigen Schliff entlang der gesamten Länge der verarbeiteten Kante; dabei wird die natürliche Linienführung der Platte wiedergegeben was mit einem Fräser, der durch eine steife Führung geführt wird, sonst nicht möglich wäre. Schliff von 0 bis 12 mm breit (von 0 bis 6mm auf porzellanfliesen). Kann zwischen 22° und 90° mit jedem beliebigen Winkel eingestellt werden. Durch mehrmaliges Abtragen und verschiedenen Winkelstellungen können abgerundete Kanten hergestellt werden (normalerweise mit einem voreingestellten 6 mm Radius) Es kann die seitliche Kante der Fliese damit versäubert werden (max.30mm).

**La macchina 36B4/P con il kit 36C4, va fissata ad un banco ed è consigliata per lavorare piastrelle strette e lunghe, come piastrelle per battiscopa, striscie di piastrelle spessore 3÷20mm, ecc. e dimensione da 30 cm a infinito.**

**The machine 36B4/P with the kit 36C4, to be fixed on a table, and recommended for long and narrow tile working, like skirting tiles, strips of tile 3 to 20mm thick, etc. and size from 30 cm to infinity.**

**La machine 36B4/P avec le kit 36C4, doit être fixé à une table et est recommandé pour les travaux de carrelage long et étroit, comme en contournant tuiles, des bandes de l'épaisseur du carrelage de 3 à 20 mm, etc. et la taille de 30 cm à l'infini.**

**Die Maschine 36B4/P mit Satz 36C4, muss auf einer Werkbank befestigt werden und eignet sich um schmale und lange Fliesen zu verarbeiten wie z.B. Sockel Leisten, Fliesen Streifen mit einer Dicke von 3÷20mm, usw. und ab 30 cm bis endlos.**

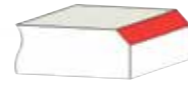

**36A4D The machine is suitable for the following processes:**

Finishing and polishing of lateral edge on tiles, cut with blade. 2 to 30mm thick tiles. Machining at 90°. Using grinding wheel art. 72E0200/0800/1500

Bevel, finishing and polishing of tiles edge, cut with blade. Angle 22°÷90°. Back miter width 1÷4mm, on gres porcelain material, Using grinding wheel art. 72E0050/0200/0800/1500

Creating BULL NOSE on tiles edge, cut with blade. BULL width: 3÷7mm, on gres porcelain material, Using grinding wheel art. 72E0050

For large bullnose, we recommend Art. 37A2D

Finishing and polishing of tiles edge, previously chamfered with blade. Angle 22°÷90°. Chamfer width: 1÷18mm on gres porcelain material. Using grinding wheel art. 72E0200/0800/1500

Beveling, Finishing and polishing of tiles edge, cut with blade. Angle 22°÷90°. Bevel width 4÷18mm **All materials: roughing grindstone Article 72, with multiple steps 3mm deep.** Finishing and polishing with grinding wheel art. 72E0200/0800/1500

For large chamfer, we recommend Art. 37A2D

**Art. 36A4D**

**Art. 36A4DP**



72D / 72DP + 72E0050

**Art. 36C4**



72E0050 72E0200 72E0800 72E1500



Art.	Descrizione	Description	
	<b>SIMPLE BEVEL</b> predisposto per smerigliatrici 700 - 1400 W. <b>completo di art.72D/72DP + 72E</b> capacità disco max.100mm	<b>SIMPLE BEVEL</b> ready for grinder 700 - 1400W. <b>complete with art.72D/72DP + 72E</b> disk capacity max. 4"	
36A4D	con attacco <b>M14</b>	with spindle thread <b>M14</b>	1
36A4PD	con attacco <b>5/8-11 UNC</b> ; per U.S.A. - Canada	with spindle thread <b>5/8-11 UNC</b> ; for U.S.A. - Canada	1
	Accessori a richiesta	Accessoires on request	
36C4	Kit fissaggio al banco per smussatura battiscopa per art. 36A4-36A4P	Table Fixing kit for bevel skirting. For art. 36A4-36A4P	1
	Mola Diamantata Ø 100 a LUNGA DURATA Mole consigliate per smussi sopra i 4 mm. Velocità: 5000/11000 rpm.	<b>LONG LIFE</b> Diamond Grinding Wheels Ø 100 Recommended for chamfer above 4 mm. Speed: 5000/11000 rpm.	
72	Mola Ø Diamantata 100 attacco <b>M14</b>	Diamond Grinding Wheels Ø 100 thread <b>M14</b>	1
72P	Mola Diamantata Ø 100 attacco <b>5/8-11 UNC</b>	Diamond Grinding Wheels Ø 100 spindle thread <b>5/8-11 UNC</b>	1
	Mole consigliate per smussi sotto i 4 mm. Velocità: 3000/11000 rpm.	Recommended for chamfer below 4 mm. Speed: 3000/11000 rpm.	
72D	Platorello Ø100 mm Attacco <b>M14</b> per traino mole con velcro	Pad Diam. 100 mm <b>M14</b> thread for grinding wheel with velcro	1
72DP	Platorello Ø100 mm Attacco <b>5/8-11 UNC</b> per traino mole con velcro	Pad Diam.100 <b>5/8-11 UNC</b> spindle thread for grinding wheel with velcro	1
	Mola diamantata Ø100 mm con velcro	Diamond Grinding wheel Ø100 mm - 4" with velcro	
72E0050	Grana 50 per <b>sgrossatura</b>	50-grit <b>roughing</b>	10
72E0200	Grana 200 per <b>finitura</b>	200-grit for <b>finishing</b>	10
72E0800	Grana 800 per <b>semi-lucidatura</b>	800-grit for <b>semi-polishing</b>	10
72E1500	Grana 1500 per <b>lucidatura</b>	1500-grit for <b>polishing</b>	10

**patented**



**sigmaitalia**

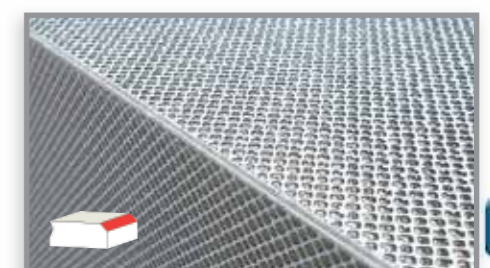
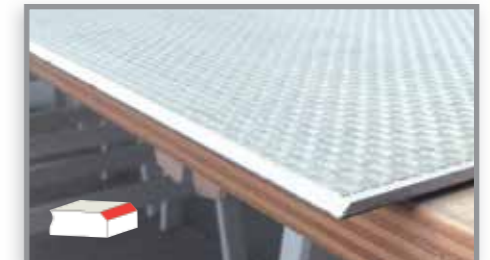

**Art. 36A4D + Art. 36C4 +**

Art.				
<b>36A4D - 36A4PD</b>	4,5 Kg.	1 pz.	5,8 Kg.	52 x 38 x 22 cm.



Dischi diamantati

Diamond blade

Disques diamantées

Diamantscheiben

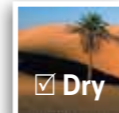

velocità - speed	[Progress bar]	
finitura - finish	[Progress bar]	
durata - life	350 linear mt *	
	spessore - thickness	resa - performance
gres porcellanato - porcelain	6 - 25 mm	[Green]
gres smaltato - glazed gres	6 - 25 mm	[Green]
dekton	6 - 25 mm	[Green]
pietra - stone	6 - 25 mm	[Yellow]
granito - granite	6 - 25 mm	[Yellow]
marmo - marble	6 - 25 mm	[Yellow]
monocottura-single fired	6 - 25 mm	[Green]
cemento - beton	6 - 25 mm	[Yellow]
cotto - brick	6 - 25 mm	[Green]

Art.	Descrizione	Description	
75B	Disco diamantato Ø 115mm foro 22,2 mm, spes.1,4 mm	Diamond disc Ø 115 mm bore 22,2 mm, thick 1,3 mm	10
75D	Disco diamantato Ø 125mm foro 22,2 mm, spes.1,4 mm	Diamond disc Ø 125 mm bore 22,2 mm, thick 1,4 mm	10

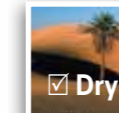

velocità - speed	[Progress bar]	
finitura - finish	[Progress bar]	
durata - life	350 linear mt *	
	spessore - thickness	resa - performance
gres porcellanato - porcelain	3 - 12 mm	[Green]
gres smaltato - glazed gres	3 - 12 mm	[Green]
dekton	3 - 12 mm	[Green]
pietra - stone	3 - 15 mm	[Yellow]
granito - granite	3 - 15 mm	[Yellow]
marmo - marble	3 - 15 mm	[Yellow]
monocottura-single fired	3 - 15 mm	[Green]
cemento - beton	3 - 15 mm	[Yellow]
cotto - brick	3 - 15 mm	[Green]

Art.	Descrizione	Description	
75C	Disco diamantato Ø 115mm foro 22,2 mm, spessore 1,5 mm	Diamond blade Ø 115mm hole 22.2 mm, thickness 1.5 mm	10

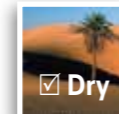

velocità - speed	[Progress bar]	
finitura - finish	[Progress bar]	
durata - life	400 linear mt *	
	spessore - thickness	resa - performance
gres porcellanato - porcelain	6 - 25 mm	[Green]
gres smaltato - glazed gres	6 - 25 mm	[Green]
dekton	6 - 25 mm	[Green]
pietra - stone	6 - 25 mm	[Yellow]
granito - granite	6 - 25 mm	[Yellow]
marmo - marble	6 - 25 mm	[Yellow]
monocottura-single fired	6 - 25 mm	[Green]
cemento - beton	6 - 25 mm	[Yellow]
cotto - brick	6 - 25 mm	[Green]

NEW

Art.	Descrizione	Description	
75XR1	Disco diamantato Ø 115mm foro 22,2 mm, spes.1,4 mm	Diamond blade Ø 115mm hole 22.2 mm, thickness 1.4 mm	10

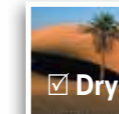

velocità - speed	[Progress bar]	
finitura - finish	[Progress bar]	
durata - life	400 linear mt *	
	spessore - thickness	resa - performance
gres porcellanato - porcelain	3 - 6 mm	[Yellow]
gres smaltato - glazed gres	3 - 6 mm	[Yellow]
dekton	3 - 6 mm	[Yellow]
vetro - glass	3 - 20 mm	[Green]
mosaico vetroso - glass	3 - 10 mm	[Green]

Art.	Descrizione	Description	
75V	Disco diamantato Ø 100mm foro 22,2 mm, spes.1,2mm	Diamond blade Ø 100mm hole 22.2 mm, thickness 1.2 mm	1

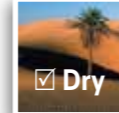

velocità - speed	[Progress bar]	
finitura - finish	[Progress bar]	
durata - life	400 linear mt *	
	spessore - thickness	resa - performance
gres porcellanato - porcelain	3 - 12 mm	[Green]
gres smaltato - glazed gres	3 - 12 mm	[Green]
dekton	3 - 12 mm	[Green]
pietra - stone	3 - 15 mm	[Yellow]
granito - granite	3 - 15 mm	[Yellow]
marmo - marble	3 - 15 mm	[Yellow]
monocottura-single fired	3 - 15 mm	[Green]
cemento - beton	3 - 15 mm	[Yellow]
cotto - brick	3 - 15 mm	[Green]

NEW

Art.	Descrizione	Description	
75C3	Disco diamantato Ø 115mm foro 22,2 mm, spes.1,1 mm	Diamond blade Ø 115mm hole 22.2 mm, thickness 1.1 mm	10

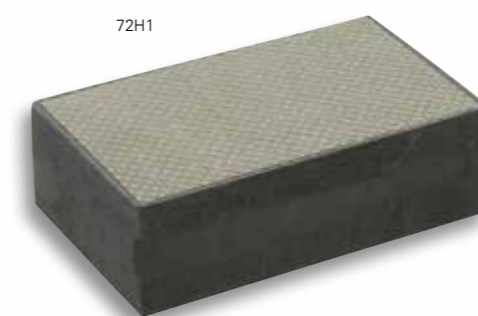

Art.	Descrizione	Description	
72H1	Tampone diamantato Grana 120 per finitura a mano 93x58x27	Diamond pad for hand finishing; 120-grit; 93x58x27	10
100533	Stick per ravnatura utensili diamantati cm. 21,5x10x5,5	Grindstone for dressing of diamond tools cm. 21,5x10x5,5	1

\* media indicativa su gres porcellanato spessore 10mm \*\* indicativa average on 10mm thick porcelain gres \*\* media indicativa su vetro spessore 10mm \*\* indicativa average on 10mm thick glass



**Dischi diamantati**

**Diamond blade**

**Disques diamantées**

**Diamantscheiben**

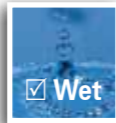
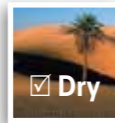
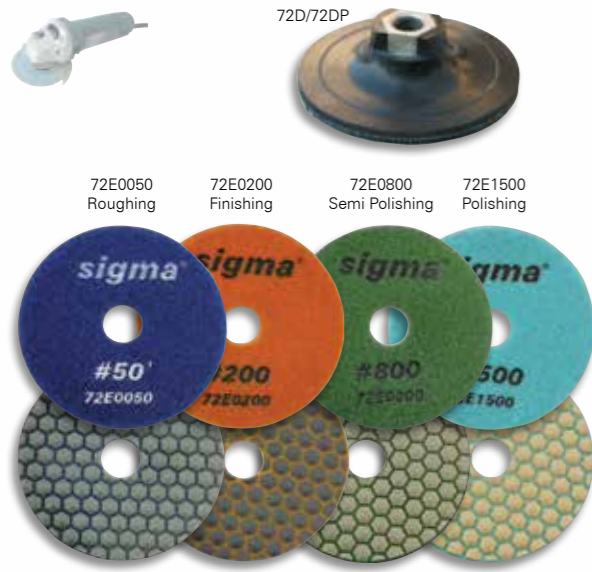

velocità di asportazione - grinding speed	[Progress bar]	
finitura - finish	[Progress bar]	
durata - life	50 cm3 porcelain gres	
	rpm	resa - performance
gres porcellanato - porcelain	consigliati 4.000	[Green]
gres smaltato - glazed gres	max 7.000	[Green]
dekton		[Green]
pietra - stone	recommended 4.000	[Yellow]
granito - granite	max 7.000	[Yellow]
marmo - marble		[Yellow]

Art.	Descrizione	Description	
	Platello Ø100 per traino mole	Pad Ø100 for grinding wheel	
72D	Attacco M14	M14 thread	1
72DP	Attacco 5/8"11 UNC	5/8"11 UNC thread	1
	Mola diamantata Ø100 con velcro	Diamond Grinding wheel Ø100 - 4" with velcro	
72E0050	Grana 50 per sgrossatura	50-grit roughing	10
72E0200	Grana 200 per finitura	200-grit for finishing	10
72E0800	Grana 800 per lucidatura opaca	800-grit for semi-polishing	10
72E1500	Grana 1500 per lucidatura	1500-grit for polishing	10

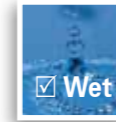
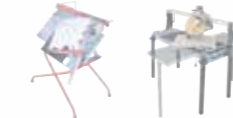

velocità - speed	[Progress bar]	
finitura - finish	[Progress bar]	
	spessore - thickness	resa - performance
gres porcellanato - porcelain	6 - 60 mm	[Green]
gres smaltato - glazed gres	6 - 60 mm	[Green]
dekton	6 - 60 mm	[Green]
pietra - stone	6 - 60 mm	[Yellow]
granito - granite	6 - 60 mm	[Yellow]
marmo - marble	6 - 60 mm	[Yellow]
monocottura-single fired	6 - 60 mm	[Green]
cemento - beton	6 - 60 mm	[Yellow]
cotto - brick	6 - 60 mm	[Yellow]

Art.	Descrizione	Description	
60B	Disco diamantato Ø 200 foro 30, spessore 2.1 mm	Diamond blade Ø 200, 30 mm hole, 2.1 mm thick	1
86C	Disco diamantato Ø 230 foro 30, spessore 2.1 mm	Diamond blade Ø 230, 30 mm hole, 2.1 mm thick	1
79C	Disco diamantato Ø 250 foro 30, spessore 2.5 mm	Diamond blade Ø 250, 30 mm hole, 2.5 mm thick	1
74C	Disco diamantato Ø 300 foro 30, spessore 2.7mm	Diamond blade Ø 300, 30 mm hole, 2.7 mm thick	1



**NEW**

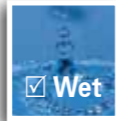
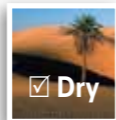

velocità di asportazione - grinding speed	[Progress bar]	
finitura - finish	[Progress bar]	
durata - life	130 cm3 porcelain gres	
	rpm	resa - performance
gres porcellanato - porcelain	max 10.500	[Green]
gres smaltato - glazed gres		[Green]
pietra - stone		[Yellow]
granito - granite		[Yellow]
marmo - marble		[Yellow]
monocottura-single fired		[Green]
cemento - beton		[Yellow]
cotto - brick		[Yellow]

Art.	Descrizione	Description	
72F060	Mola Diamantata Lamellare grana 60, Ø 115 mm, foro 22,2 (100 lamelle)	Lamellar Diamond Grinding Wheels, 60-grit, Ø 115mm hole 22.2, (100 flap)	5
72F120	Mola Diamantata Lamellare grana 120, Ø 115 mm, foro 22,2 (100 lamelle)	Lamellar Diamond Grinding Wheels, 120-grit, Ø 115mm hole 22.2, (100 flap)	5

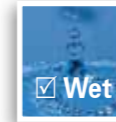
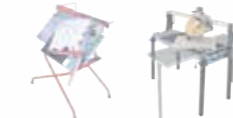

velocità - speed	[Progress bar]	
finitura - finish	[Progress bar]	
	spessore - thickness	resa - performance
gres porcellanato - porcelain	3 - 15 mm	[Green]
gres smaltato - glazed gres	3 - 15 mm	[Green]
dekton	3 - 15 mm	[Green]
pietra - stone	3 - 20 mm	[Yellow]
granito - granite	3 - 20 mm	[Yellow]
marmo - marble	3 - 30 mm	[Yellow]
monocottura-single fired	3 - 15 mm	[Green]
cemento - beton	3 - 20 mm	[Yellow]
cotto - brick	3 - 30 mm	[Yellow]

Art.	Descrizione	Description	
73	Disco diamantato Ø 300 foro 30, spessore 2.7mm	Diamond blade Ø 300, 30 mm hole, 2.7 mm thick	1

Art.	Descrizione	Description	
1073	Anello riduzione foro dischi 30 - 25,4	Reducing ring, Hole 30 - 25,4 for diamond disk	1

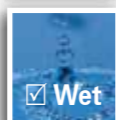
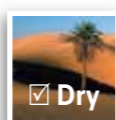
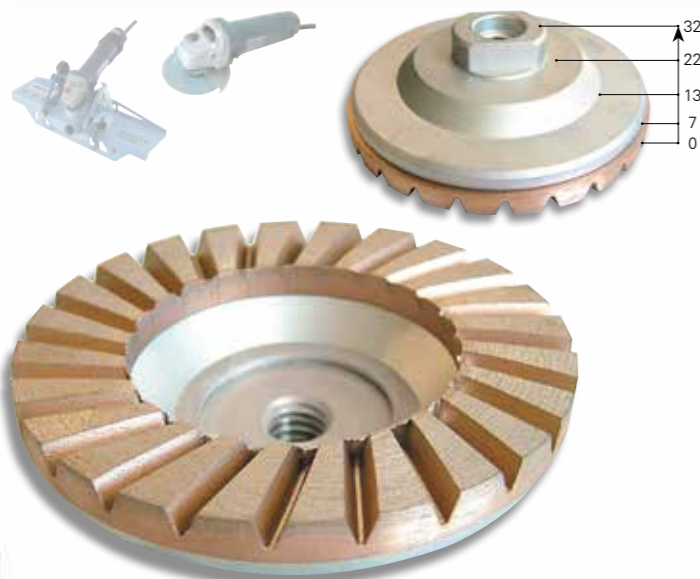

velocità di asportazione - grinding speed	[Progress bar]	
finitura - finish	[Progress bar]	
durata - life	500 cm3 porcelain gres	
	rpm	resa - performance
gres porcellanato - porcelain	consigliati 6.000 max 11.000	[Green]
gres smaltato - glazed gres		[Green]
pietra - stone		[Yellow]
granito - granite	recommended 6.000 max 11.000	[Yellow]
marmo - marble		[Yellow]
monocottura-single fired		[Green]
cemento - beton		[Yellow]
cotto - brick		[Yellow]

Art.	Descrizione	Description	
	Mola Diamantata Ø 100 a LUNGA DURATA	LONG LIFE Diamond Grinding Wheels Ø 100	
72	Attacco M14	Thread M14	1
72P	Attacco 5/8"11 UNC	Thread 5/8"11 UNC	1

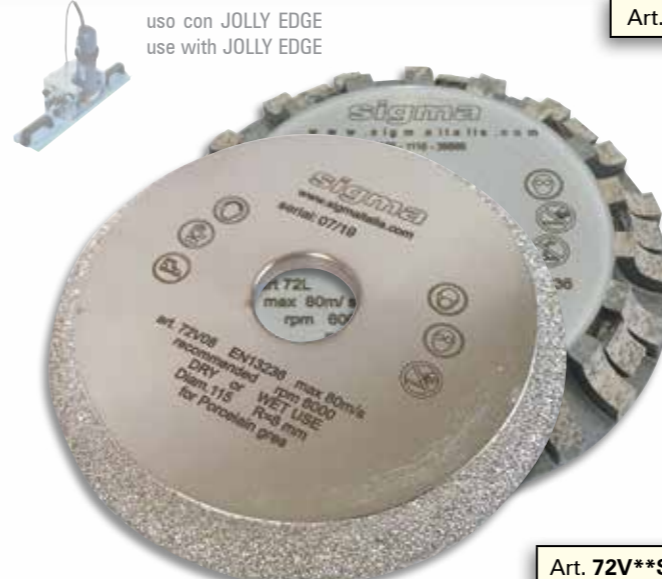

**Art. 72L**

**Art. 72V\*\*S**

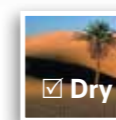

velocità di asportazione - grinding speed	[Progress bar]	
finitura - finish	[Progress bar]	
	rpm	resa - performance
gres porcellanato - porcelain	consigliati 6.000 max 11.000	[Green]
gres smaltato - glazed gres		[Green]
pietra - stone	recommended 6.000 max 11.000	[Yellow]
granito - granite		[Yellow]
marmo - marble		[Yellow]
monocottura-single fired		[Green]

Art.	Descrizione	Description	
	Mola Diamantata VACUUM completo di art.100533 durata indicativa: 300 mt.	VACUUM Diamond Grinding Wheels complete with art.100533 indicative Life: 300 mt.	
72V06S	Ø 115 / 22,2 raggio 6	Ø 115 / 22,2 radius 6	1
72V08S	Ø 115 / 22,2 raggio 8	Ø 115 / 22,2 radius 8	1
72V10S	Ø 115 / 22,2 raggio 10	Ø 115 / 22,2 radius 10	1
	Mola Diamantata a LUNGA DURATA durata indicativa: 1000 mt.	LONG LIFE Diamond Grinding Wheels indicative Life: 1000 mt.	
72L	Ø 115 / 22,2 raggio 8	Ø 115 / 22,2 radius 8	1



Frese diamantate

Diamond Drill Bit

Fraises diamantées

Diamantfräser

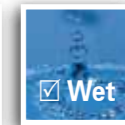
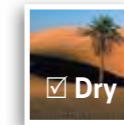
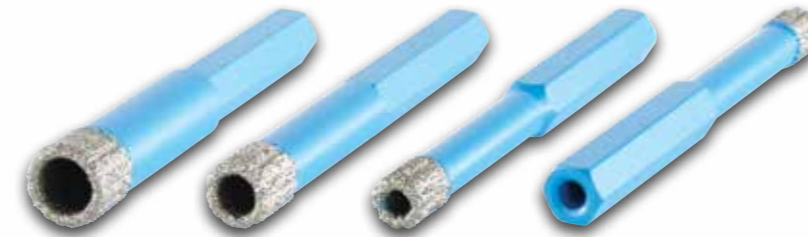
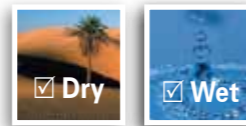

Per foratura a secco o acqua su: Gres porcellanato, Marmo, Granito, ecc. **Attacco: filettato M14 / esagonale 9mm**  
Durata: circa 60 fori su gres porcellanato.



For dry or wet drilling on: porcelain gres, marble, granite, etc. **Fixing: Thread M14 / 9mm Hex**  
Life: about 60 holes on porcelain gres.



Pour effectuer des trous à sec ou à l'eau sur: Grès porcelainé, Marbres, Granit, etc. **Attache: filet M14 / hexagonal 9mm**  
Durée: environ 60 trous sur de Gres.



Für Trocken oder Nassbohren von: Feinsteinzeug, Marmor, Granit, usw. **Anschluss: M14 Gewinde / 9mm Hex.**  
Lebensdauer: über 60 Locher auf Feinsteinzeug.

velocità di asportazione - grinding speed	durata - life	
	manually / guided	rendimento - resa
gres porcellanato - porcelain	0-15 / 35 mm	
gres smaltato - glazed gres dektion	0-15 / 35 mm	
pietra - stone	0-15 / 35 mm	
granito - granite	0-15 / 35 mm	
marmo - marble	0-15 / 35 mm	
monocottura-single fired	0-15 / 35 mm	
cemento - beton	0-15 / 35 mm	
cotto - brick	0-15 / 35 mm	

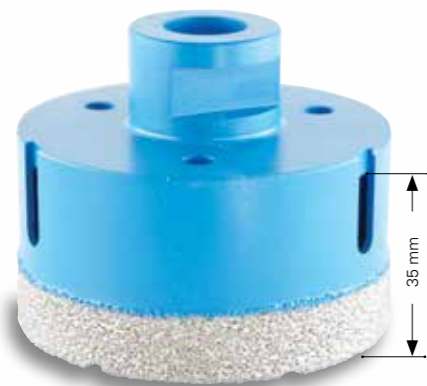

**NEW**

Art. 54020

Art.	Descrizione	Description	
	FRESE DIAMANTATE "FAST" per foratura a secco o acqua <b>Attacco: filettato M14</b> (velocità raccomandata / max rpm.)	DIAMOND DRILL BIT "FAST" for dry or wet drilling <b>Fixing: Thread M14</b>	
53020	Fresa Ø mm 20 (6000 / 11000 rpm.)	Drill Bit Ø 20 mm	5
53025	Fresa Ø mm 25 (6000 / 11000 rpm.)	Drill Bit Ø 25 mm	5
53030	Fresa Ø mm 30 (5000 / 11000 rpm.)	Drill Bit Ø 30 mm	10
53035	Fresa Ø mm 35 (4000 / 11000 rpm.)	Drill Bit Ø 35 mm	10
53040	Fresa Ø mm 40 (4000 / 11000 rpm.)	Drill Bit Ø 40 mm	5
53050	Fresa Ø mm 50 (4000 / 11000 rpm.)	Drill Bit Ø 50 mm	5
53060	Fresa Ø mm 60 (3000 / 11000 rpm.)	Drill Bit Ø 60 mm	5
53070	Fresa Ø mm 70 (3000 / 11000 rpm.)	Drill Bit Ø 70 mm	5

Art.	Descrizione	Description	
54020	Allargatore diamantato "FAST" per sagonatura a secco o ad acqua Ø mm 20 (6000 / 11000 rpm.)	Diamond enlarger "FAST" for dry or wet enlarging Ø 20 mm	1

Art.	Descrizione	Description	
	FRESE DIAMANTATE "FAST" per foratura a secco o acqua (confezionate in blister) (velocità raccomandata / max rpm.)	DIAMOND DRILL BIT "FAST" for dry or wet drilling (packaged in blister)	
53G	Gel raffreddamento per foratura a secco 30 ml.	Cooling wax / gel for dry drilling 30 ml.	20
53006	Fresa Ø mm 6 (1000 / 1500 rpm.)	Drill Bit Ø 6 mm	10
53008	Fresa Ø mm 8 (1000 / 1500 rpm.)	Drill Bit Ø 8 mm	10
53010	Fresa Ø mm 10 (1000 / 1500 rpm.)	Drill Bit Ø 10 mm	10
53012	Fresa Ø mm 12 (1000 / 1500 rpm.)	Drill Bit Ø 12 mm	10



Gel per foratura a secco, su: Gres porcellanato, Marmo, Granito, ecc. Usato durante la foratura aumenta la durata della fresa.



Cooling wax for dry drilling, on: Porcelain gres, Marble, Granite, etc. Used during drilling increases the duration of the drill bit.



Gel de perçage à sec sur: grès cérame, marbre, granit, etc. Utilisé pendant le forage augmente la durée de la fraise.



Trockenbohrwachs, auf: Feinsteinzeug, Marmor, Granit usw. Während des Bohrens erhöht sich die Dauer des Fräsers.



Art. 42E

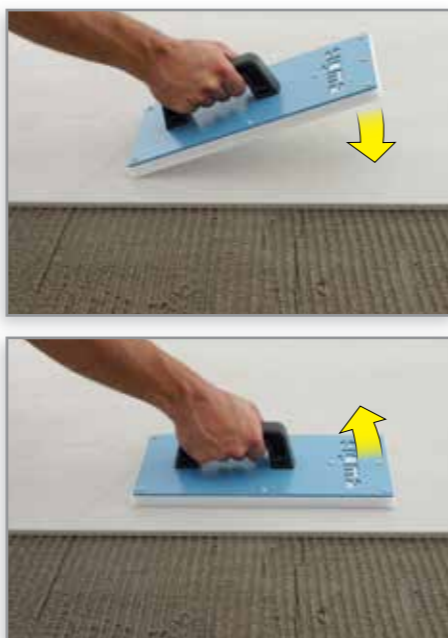

- 🇮🇹 Frattazzo Battapiastrelle 16x33 cm, specifico per la corretta espulsione dell'aria da sotto la piastrella.
- 🇬🇧 Beat Tile Trowel 16x33 cm, specific for the correct expulsion of air from under the tile.
- 🇫🇷 Truelle pour niveler les tuiles, spécialement conçu pour la sortie d'air sous les carreaux.
- 🇩🇪 Beater, um die Fliesen zu schlagen; speziell für den korrekten Luftaustritt unter der Fliese.

Art. 49E



Art. 49H



Art.	Descrizione	Description	➡
51G	Gruppo ventose MOVE	MOVE Suction Cups	1
49H	Spatole per colla INOX con impugnatura anatomica morbida, 28x13 cm dente <b>No-Air</b> .	Stainless steel trowel with soft anatomical handle, 28x13 cm <b>No-Air</b> teeth.	15
49E	Spatole per colla INOX con impugnatura anatomica morbida, 28x13 cm dente <b>4x4 mm</b> .	Stainless steel trowel with soft anatomical handle, 28x13 cm <b>4x4 mm</b> teeth.	15
42E	Frattazzo Battapiastrelle 16x33 cm. Fondo antiseagno kg. 2	Beat Tile trowel 16x33 cm. Stain Free kg.2	1

Vendita a confezioni intere Sold in full packs only ➡

🇮🇹 Art. 49H Spatola per la corretta stesura della colla SENZA ARIA, particolarmente indicata per grandi lastre, (sezione equivalente 11,5x11,5 cm).  
Per la doppia spalmatura combinare con Art. 49E (dente 4x4 mm).

🇬🇧 Art. 49H NO-AIR stainless steel trowel for glue applying, indicated for Large format tiles (equivalent section 11,5x11,5 mm).  
For double buttering, combine with Art. 49E (4x4 mm tooth).

🇫🇷 Art. 49H Spatule dentée en acier inoxydable NO-AIR pour application de colle, indiquée pour les carreaux Slim (section équivalente 11,5x11,5 mm) Pour le revêtement à double colle, combiner avec Art. 49E (dent de 4x4 mm)

🇩🇪 Art. 49H Spachtel für die korrekte Verlegung des Klebstoffes OHNE LUFT, besonders geeignet für Slim-Fliesen (äquivalenter Querschnitt 11,5x11,5 mm).  
Für Doppelbeschichtung mit Art. 49E (4x4 mm Zahn) kombinieren.

Art. 51G



- 🇮🇹 Il Gruppo ventose MOVE è indispensabile per il corretto avvicinamento delle lastre di grande formato grazie alle quattro ventose antimacchia, a forte tenuta, anche su materiali ruvidi.
- 🇬🇧 The MOVE suction cups is indispensable for the correct approach of the large format tiles, thanks to the four strong stain-free suction cups adherents also on rough materials
- 🇫🇷 Les ventouses MOVE est indispensable à l'approche correcte des carreaux de grand format, grâce aux quatre fortes anti-taches ventouses, adhérents aussi sur des matériaux bruts.
- 🇩🇪 Die MOVE Saugnäpfe sind unverzichtbar für die richtige Annäherung der großformatigen Fliesen, dank der vier starken schmutzabweisend Saugnäpfe auch an rauhen Materialien.





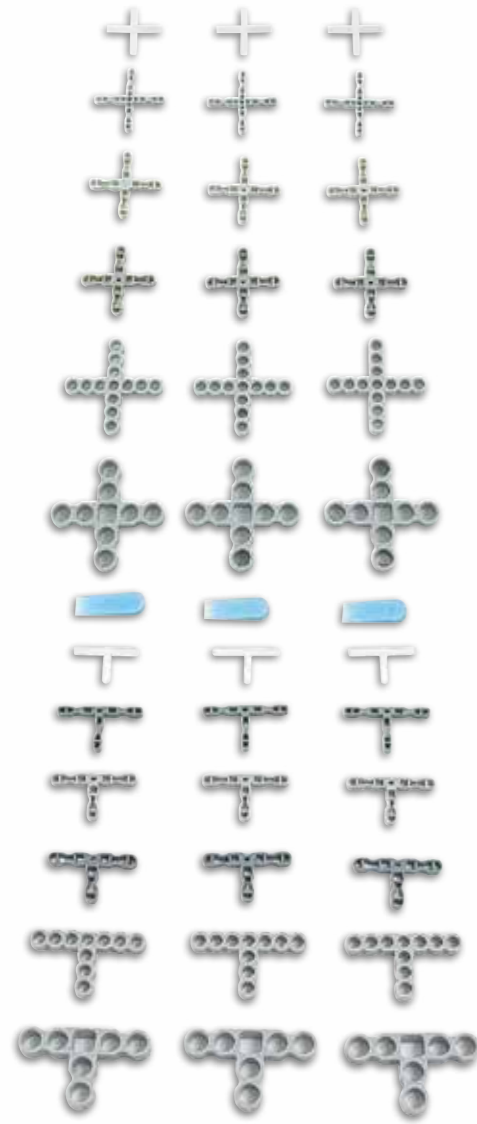

Art.	Descrizione	Description	
	<b>Distanziatori per piastrelle sacchetti da 500 pezzi</b>	<b>Tiling Spacers bags of 500 pieces</b>	
40-X1	500 pz. a X spessore mm.1 - H.4	500 pcs. X thickness mm.1 - H.4	40
40-X2	500 pz. a X spessore mm.2 - H.4	500 pcs. X thickness mm.2 - H.4	40
40-X3	500 pz. a X spessore mm.3 - H.4,5	500 pcs. X thickness mm.3 - H.4,5	40
40-X4	500 pz. a X spessore mm.4 - H.4,5	500 pcs. X thickness mm.4 - H.4,5	40
40-X5	500 pz. a X spessore mm.5 - H.4,5	500 pcs. X thickness mm.5 - H.4,5	40
40-X7	500 pz. a X spessore mm.7 - H.6	500 pcs. X thickness mm.7 - H.6	10
40-X10	500 pz. a X spessore mm.10 - H.8	500 pcs. X thickness mm.10 - H.8	10
40-C	500 Spessori a Cuneo 0-5 mm.	500 Tiling Wedges 0-5 mm.	40
40-T1	500 pz. a T spessore mm.1 - H.4	500 pcs. T thickness mm.1 - H.4	40
40-T2	500 pz. a T spessore mm.2 - H.4	500 pcs. T thickness mm.2 - H.4	40
40-T3	500 pz. a T spessore mm.3 - H.4,5	500 pcs. T thickness mm.3 - H.4,5	40
40-T4	500 pz. a T spessore mm.4 - H.4,5	500 pcs. T thickness mm.4 - H.4,5	40
40-T5	500 pz. a T spessore mm.5 - H.4,5	500 pcs. T thickness mm.5 - H.4,5	40
40-T7	500 pz. a T spessore mm.7 - H.6	500 pcs. T thickness mm.7 - H.6	10
40-T10	500 pz. a T spessore mm.10 - H.8	500 pcs. T thickness mm.10 - H.8	10
	<b>Vendita a confezioni intere</b>	<b>Sold in full packs only</b>	
	<small>Distanziatori rimovibili non soggetti a DoP-dichiarazione di prestazione (distanziatori da da asportare a fine lavoro se si vuol garantire la robustezza della stuccatura)</small>	<small>Removable spacers not subject to DoP (Spacers to be removed after work if you want to ensure the robustness of grouting)</small>	

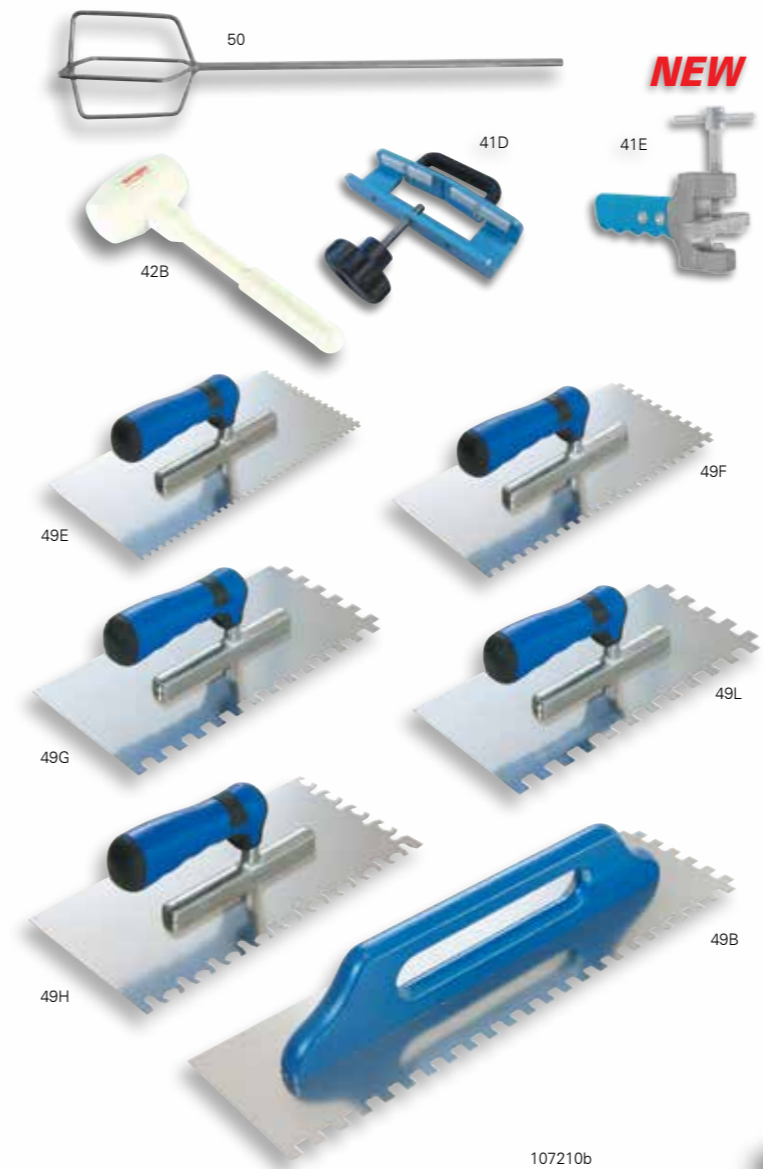

Art.	Descrizione	Description	
50	Frusta mescolatore Diam.120 mm per trapano	Whisk mixer D.120 mm, hexagonal junction for electric drill	10
42B	Mazzetto gomma antiseagno 700 gr.	Rubber hammer Stain-Free 700 gr.	6
<b>NEW</b>	SEPARATORE universale per piastrelle preincise	Universal SEPARATOR for pre-scored tiles	
41E	0 > 15mm disp.dal 11/2020	0 > 15mm available from 11/2020	1
41D	0 > 30mm	0 > 30mm	1

Art.	Descrizione	Description	
49E	Spatole per colla INOX con impugnatura anatomica morbida, 28x13 cm dente 4x4 mm.	Stainless steel trowel with soft anatomical handle, 28x13 cm 4x4 mm teeth.	30
49F	Spatole per colla INOX con impugnatura anatomica morbida, 28x13 cm dente 6x6 mm.	Stainless steel trowel with soft anatomical handle, 28x13 cm 6x6 mm teeth.	30
49G	Spatole per colla INOX con impugnatura anatomica morbida, 28x13 cm dente 10x10 mm.	Stainless steel trowel with soft anatomical handle, 28x13 cm 10x10 mm teeth.	30
49L	Spatole per colla INOX con impugnatura anatomica morbida, 28x13 cm dente 12x12 mm.	Stainless steel trowel with soft anatomical handle, 28x13 cm 12x12 mm teeth.	30
49H	Spatola INOX per la corretta stesura della colla <b>SENZA ARIA</b> , particolarmente indicata per Slim-tiles, piastrelle di grandi dimensioni e mosaico (sezione equivalente 11,5x11,5 cm). con impugnatura anatomica	Stainless steel trowel for correct <b>AIR-FREE</b> thinset application, particularly suitable for Slim-tiles, large tiles dimensions and mosaic (section equivalent 11.5x11.5 cm). with soft anatomical handle	30
49B	Spatole per colla INOX con impugnatura in legno, 48x13 cm dente 10x10 mm.	Stainless steel trowel with wood handle, 48x13 cm 10x10 mm teeth.	10
	<b>Vendita a confezioni intere</b>	<b>Sold in full packs only</b>	



Art.	Descrizione	Description	
51P1	Ventosa a pompa Ø150 con valigia, ottima anche per materiali ruvidi. Portata max 90kg (45kg a norme CE) gomma antimacchia	Pump Suction Cup Ø150 mm Also with suitcase, excellent for rough materials. Capacity max 90kg (45 kg to CE rules) Stain-free rubber	1
51F1	Filtro Ø 11 per Ventosa a pompa Ø150	Filter Ø 11 for Pump Suction Cup Ø150 mm	1
10518	Protezione per la gomma delle ventose Ø150	Protection for the rubber of Ø150 suction cups	1
51L	Ventosa doppia in alluminio Ø120 a forte bloccaggio, specifica per materiali ruvidi. Portata max 80kg (40 kg a norme CE) gomma antimacchia	Double Alluminium Suction Cup Ø120 mm Strong locking. Specific for rough materials. Capacity max 80kg (40 kg to CE rules) Stain-free rubber	1
51B	Ventosa in alluminio Ø120 a forte bloccaggio, specifica per materiali ruvidi. Portata max 40kg (10 kg a norme CE) gomma antimacchia	Alluminium Suction Cup Ø120 mm Strong locking. Specific for rough materials. Capacity max 40kg (10 kg to CE rules) Stain-free rubber	10
51F	Gomma per ventosa 51B-D-A-L Ø120	Rubber plate for suction cup 51B-D-A-L Ø120	1



Art.	Descrizione	Description	
	Materiale espositivo (condizioni particolari a richiesta)	Exhibition materials (special conditions on request)	
107210a	Targa adesiva trasparente 500x200 mm	Transparent adhesive label 500x200 mm	1
107210b	Banner in tela 2000x800 mm	Banner in cloth 2000x800 mm	1
101215	Poster 685x960 mm	Poster 685x960 mm	1
95E	ESPOSITORE VERTICALE a fascepiani, altezza cm.200 con pannello accessori a 10 posti + 4 posti taglia piastrelle	VERTICAL DISPLAY with shelves height cm 200, set for fixing a tile cutter Art. -3L*-3A*-3B*-3C*-3D*-3P*-3E*-3F*	1



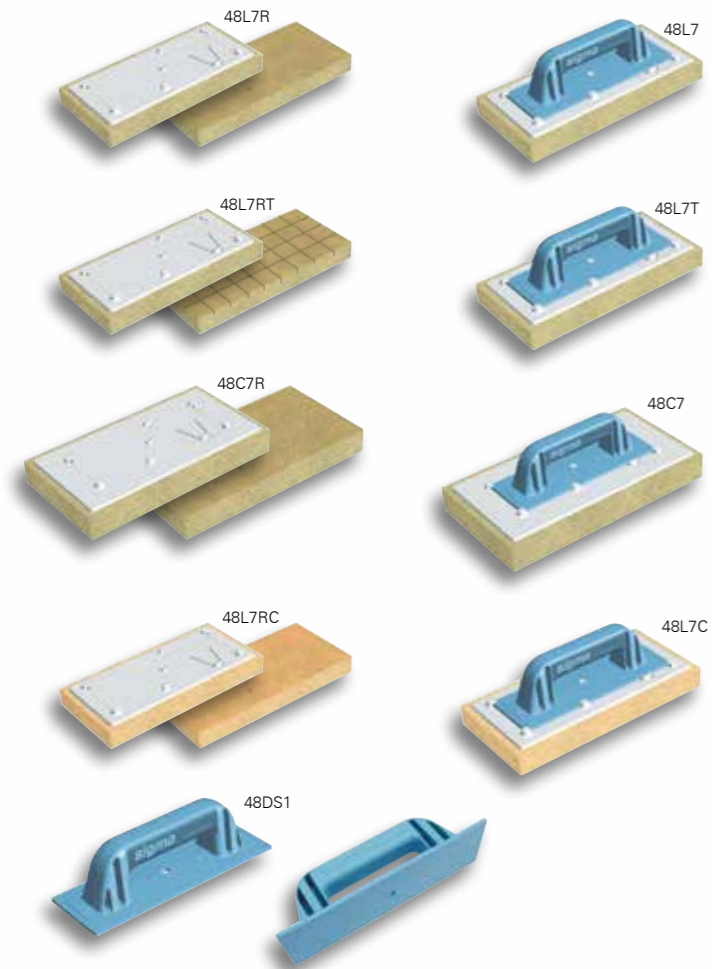

Scegli la tua combinazione  
Choose your configuration

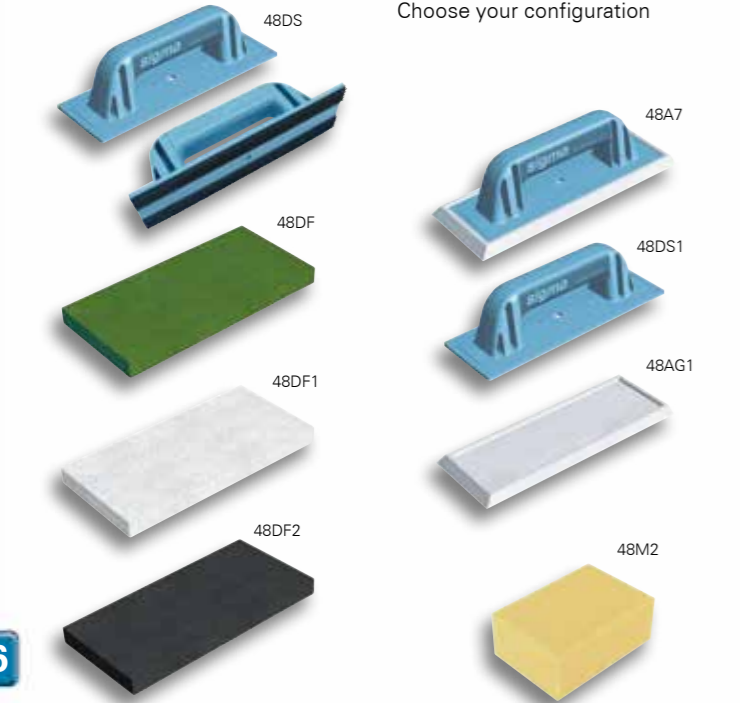

Art.	Descrizione	Description	
48L7	Frattazzo spugna ad alto assorbimento a smontaggio rapido, 30x14x3cm.	High absorption sponge float with quick disassembly 30x14x3cm.	15
48L7R	Ricambio per frattazzo 30x14x3 cm. Art.48L7 Spugna ad alto assorbimento	Spare sponge float 30x14x3cm for Art.48L7 High absorption sponge	30
48L7T	Frattazzo spugna ad alto assorbimento a smontaggio rapido, con intagli 30x14x3cm.	High absorption sponge trowel with cuts (rapid disassembly) 30x14x3cm.	15
48L7RT	Ricambio per frattazzo, con intagli 30x14x3 cm. Art.48L7T Spugna ad alto assorbimento	Spare sponge float with cuts 30x14x3cm for Art.48L7T High absorption sponge	30
48C7	Frattazzo spugna ad alto assorbimento a smontaggio rapido, 34x18x4 cm.	High absorption sponge float with quick disassembly 34x18x3cm.	10
48C7R	Ricambio per frattazzo 34x18x4 cm. Art.48C7 Spugna ad alto assorbimento	Spare sponge float 38x18x3cm for Art.48C7 High absorption sponge	10
48L7C	Frattazzo spugna <b>cellulosa</b> per <b>resina epossidica</b> a smontaggio rapido, 30x14x3cm.	Cellulose sponge float for epoxy resin with quick disassembly 30x14x3cm.	15
48L7RC	Ricambio per frattazzo 30x14x3 cm. Art.48L7C Spugna <b>cellulosa</b> per <b>resina epossidica</b>	Spare sponge float 30x14x3cm for Art.48L7C Cellulose sponge float for <b>epoxy resin</b>	30
48DS1	Impugnatura intercambiabile per Art. 48C7-48C7T-48L7-48L7T	Interchangeable handle for Art. 48C7-48C7T-48L7-48L7T	30

Vendita a confezioni intere Sold in full packs only

Art.	Descrizione	Description	
48A7	Frattazzo 25x10 cm. con gomma di durezza media (50 shore) per stuccatura doppia angolazione 55°-70°	Rubber grout float 25x10cm with medium hardness (50 shore). Double angle 55°-70°	30
48DS1	Impugnatura intercambiabile per Art. 48A7	Interchangeable handle for Art. 48A7	40
48AG1	Gomma bianca ricambio per Art.48A7 55°-70° 50 sh	Spare part rubber for Art. 48A7 55°-70° 50sh	10
48DS	Impugnatura intercambiabile con velcro per feltro	Interchangeable handle with velcro for grout float	12
48DF	Feltro verde, medio 25x12 cm. ricambio per Art.48D7	Medium green felt 25x12 cm. spare for Art.48D7	12
48DF1	Feltro bianco, delicato 25x12 cm. ricambio per Art.48D7	White felt, delicate 25x12 cm. spare for Art.48D7	12
48DF2	Feltro nero, forte 25x12 cm. ricambio per Art.48D7	Strong black grout float 25x12 cm. Spare for Art. 48D7	12
48M2	Spugna ad alto assorbimento cm. 18x12x6	High absorption sponge 18x12x6 cm.	50

Vendita a confezioni intere Sold in full packs only



Art.	Descrizione	Description	
46	Giocchiere professionali alta qualità U.S.A. avvolgenti con elastici in silicone (paio)	Professional knee wrap high quality U.S.A. with Silicone rubber strap (pair)	1
46C1	Set di 8 bottoni (4 lunghi + 4 corti) per Art. 46	Set of 8 buttons (4+4) for Art.46	1
46D1	Set di 4 elastici al silicone per Art. 46 (4pz)	Set of 4 silicone rubber strap for Art.46 (4pcs)	1
46E1	Set di 2 imbottiture di ricambio per Art.46 (2pz)	Set of 2 padding replacement for art.46 (2pcs)	1

Vendita a confezioni intere Sold in full packs only

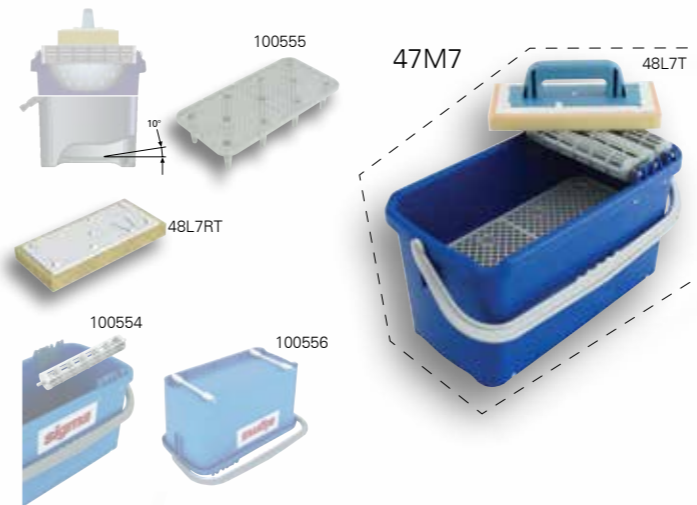

Art.	Descrizione	Description	
47M7	Vasca lavaggio-strizzatura (dim. 56x29x30) con 3 rulli perno acciaio, manico e ruote, completa di frattazzo spugna ad alto assorbimento 30x14x3 cm. (Art.48L7T).	Wash bucket (dim.56x29x30) with 3 steel pin rollers, handle and wheels, complete with high absorption sponge float with cuts 30x14x3 cm. (Art.48L7T)	1
48L7RT	Ricambio per frattazzo, con intagli Art.48L7T 30x14x3 cm. Spugna ad alto assorbimento	Spare sponge float with cuts 30x14x3cm for Art.48L7T High absorption sponge	30
100554	Rullo strizzatore forato, perno acciaio per art. 47M7	Drilled wringing roller, with steel pin for Art.47M7	3
100556	Rullo ruota singolo per art. 47M7 - 47M8	Single Roller-wheel per art. 47M7 - 47M8	2
100555	Griglia per 47M7 - 47M8	Grid for art. 47M7 - 47M8	1
Ricambi vecchi modelli Old models spare parts			
100534	Rullo strizzatore forato, perno integrale per art. 47M8	Drilled wringing roller, integral pin for Art.47M8	2
48F3	Ricambio per frattazzo, spugna ad alto assorbimento 40x12.5x3 cm. art.48G3	Spare high absorption sponge, for trowel 40x12.5x3 cm. art.48G3	5

Vendita a confezioni intere Sold in full packs only



Art. 5A cm.51

Art. 5B cm.62

Art. 4A cm.75

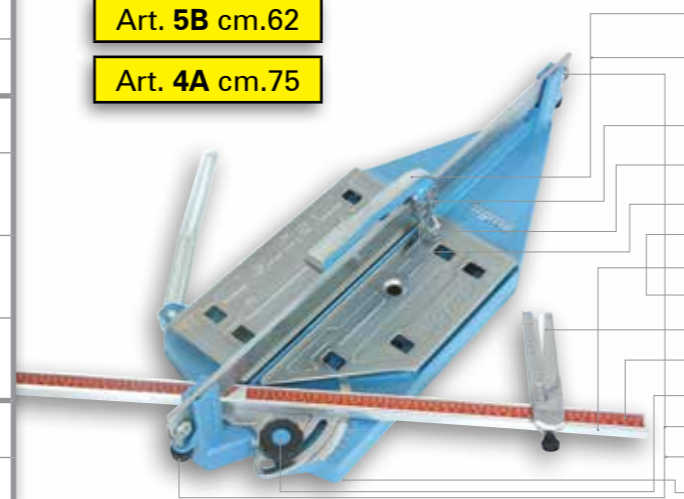

5A	5B	4A	Art.	Ricambi	Spare parts	
●	●		24E	Impugnatura a trazione scavo 8, completa di 14A	Pulling handle 8 mm groove, with Art.14A	1
		●	24AE	Impugnatura a trazione scavo 10, completa di 14A	Pulling handle 10 mm groove, with Art.14A	1
●	●	●	14A	Rotella per incisione Ø 12	Ø 12 mm scoring wheel	10
●	●	●	104033	Protezione sottopiede anti-segno per impugnatura	NO-MARK protection for Pulling handle	5
●	●	●	10144	Cuscinetto a sfere 16/5/5	Ball bearing 16/5/5	1
●	●		90B	Barra orientabile per Art. 5A	Swivel measurement bar	1
	●		90C	Barra orientabile per Art. 5B	Swivel measurement bar	1
		●	90	Barra orientabile per Art. 4A	Swivel measurement bar	1
●	●	●	19A	Squadretta	Square	1
●	●	●	91	Righetta metrica adesiva	Measurement tape	1
●	●	●	92	Pomolo Ø60 M10x25	Clamping knob Ø60 M10x25	1
●	●		20	Bilico scavo 8 completo	Compl. support screw 8pp	2
●	●		20A	Bilico scavo 10 completo	Compl. support screw 10	2
●	●	●	10675	Tappo piede Ø 15	Rubber foot Ø 15	6



## Condizioni di vendita

## Condittins de vente

CONDIZIONI GENERALI DI VENDITA in vigore dal 16 09 2018

1. Disposizioni Generali. I termini e le condizioni qui di seguito indicati formano parte integrante dei contratti conclusi tra il Venditore "Sigma di Evaristo Ambrogiani & C. Snc" e l'Acquirente per la fornitura dei prodotti del Venditore. Le presenti condizioni si applicano a tutte le transazioni concluse tra il Venditore e l'Acquirente senza la necessità che vi sia un espresso richiamo alle stesse o uno specifico accordo in tal senso alla conclusione di ogni singola transazione. Qualsiasi condizione o termine differente trova applicazione soltanto se confermato per iscritto da parte del Venditore a pena di nullità. Il Venditore si riserva il diritto di modificare, integrare o variare le presenti condizioni, allegando tali variazioni alle offerte ovvero a qualsivoglia corrispondenza inviata per iscritto all'Acquirente.

2. Offerte e Ordini. (a) Le offerte del Venditore non sono da considerarsi vincolanti, in particolare con riferimento alle quantità, ai prezzi e ai termini di consegna. Le conferme d'ordine in attesa di istruzione e/o risposta dall'Acquirente, avranno validità di giorni 15 (quindici).

(b) Gli ordini effettuati dall'Acquirente non s'intendono accettati finché non siano stati confermati per iscritto da parte del Venditore. Se il Venditore non provveda alla conferma per iscritto di un ordine negoziato verbalmente, l'emissione della fattura da parte del Venditore oppure l'esecuzione dell'ordine da parte del Venditore sarà considerata quale conferma.

(c) Gli ordini devono contenere il codice articolo del prodotto rilevabile dal listino prezzi e dal catalogo. Nel caso lo stesso ordine venga trasmesso più volte e/o da canali diversi, esso deve riportare la dicitura "ordine già trasmesso". Se l'ordine viene spedito doppio per carenza di comunicazione di cui sopra, le spese di reso sono a carico dell'acquirente.

(d) Gli ordini e/o le modifiche di ordini effettuati verbalmente o telefonicamente devono essere confermati per iscritto da parte dell'Acquirente. In caso contrario il Venditore non si assume alcuna responsabilità con riguardo a eventuali errori o possibili fraintendimenti.

(e) Gli ordini di valore inferiore a euro 50,00 sono gravati di euro 5,00 per spese amministrative. Gli ordini di valore inferiore a euro 150,00 sono effettuati con pagamento in contrassegno o anticipato.

3. Prezzi e Termini di Pagamento. (a) I Prezzi dei Prodotti non sono comprensivi di IVA, che deve essere corrisposta al momento della consegna o in conformità alle specifiche disposizioni indicate nella fattura.

(b) Tasse, imposte, dazi, spedizione, non sono incluse nei prezzi ma quotate separatamente.

(c) In aggiunta agli altri rimedi consentiti dalla legge o dalle presenti condizioni il Venditore si riserva il diritto di applicare interessi di mora sui ritardati pagamenti a decorrere dalla data in cui sia maturato il diritto al pagamento, calcolati al tasso ufficiale di riferimento della Banca Centrale Europea aumentato di 7 (sette) punti (Dir. 2000/35/CE e dal D.Lgs. 231 del 09/10/2002) nonché al rimborso di ogni consequenziale spesa sostenuta dal venditore a causa del ritardato e/o omesso pagamento.

(d) Nel caso in cui l'Acquirente non effettui il pagamento nei termini e secondo le modalità indicate dal Venditore o nel caso in cui l'attività dell'acquirente sia condotta non in conformità al corso ordinario degli affari, con ciò intendendosi, senza alcuna limitazione, l'emissione di atti di sequestro o di protesti, o quando i pagamenti siano stati ritardati o siano state richieste o promosse procedure concorsuali, il Venditore ha il diritto, a propria discrezione, di sospendere o di cancellare ulteriori consegne e di dichiarare qualsiasi pretesa derivante dal rapporto d'affari come immediatamente esigibile. Inoltre il Venditore può in tali casi richiedere anticipi sui pagamenti o un deposito in garanzia. Il compratore risponde di eventuali insoluiti.

(e) L'Acquirente è tenuto al pagamento integrale del prezzo della merce e non ha alcun diritto di effettuare alcun arrotondamento, compensazione, trattenuta o riduzione tranne che nel caso in cui la propria domanda in tal senso sia stata definitivamente e giudizialmente accolta.

4. Termini di Consegna. (a) Salvo diversa pattuizione scritta, la merce viene consegnata EXW (Franco Fabbrica) (Incoterms versione 2010) con un mezzo scelto dal compratore.

(b) Se non diversamente concordato per iscritto, qualsiasi termine di disponibilità indicato nella conferma d'ordine non è vincolante per il Venditore e, salvo diverso accordo, il termine di disponibilità indicativo è quello precisato nella conferma d'ordine.

(c) Salvo diversa comunicazione scritta dell'acquirente, il venditore si riserva il diritto di effettuare consegne parziali e l'acquirente accetterà la consegna e pagherà i prodotti consegnati. La consegna sarà effettuata come stabilito al punto 4.(a).

(d) Se per qualsiasi evento di forza maggiore o in qualsiasi caso di eccessiva onerosità o per altri eventi imprevedibili non imputabili al Venditore, ivi inclusi, senza alcuna limitazione, scioperi, serrate, disposizioni della pubblica amministrazione, successivi blocchi delle possibilità di esportazione o importazione, in considerazione della loro durata e della loro portata, l'esecuzione degli obblighi del venditore sia divenuta -prima della loro esecuzione- temporaneamente impossibile o eccessivamente onerosa, il venditore può chiedere una revisione delle condizioni contrattuali e, in mancanza, dichiarare risolto il contratto senza onere alcuno per il venditore e lo liberano dall'obbligo di rispettare i termini di consegna pattuiti.

(e) Il Venditore non è obbligato ad accettare resi dei prodotti, salvo che sia stato espressamente pattuito per iscritto. Qualsiasi costo a tal fine sostenuto è a carico dell'Acquirente.

5. Dovere di Ispezione e Accettazione dei Prodotti. (a) Qualunque sia la resa, la merce viaggia a rischio e pericolo dell'Acquirente, pertanto ogni reclamo dovrà essere rivolto direttamente al vettore e dichiarato sul documento di trasporto prima di firmare per ricevuta. Non si risponde di difetti di conformità derivanti da schiacciamenti o graffiature dei prodotti causati dal trasporto e/o dalla movimentazione.

(b) Al momento della presa in consegna dei Prodotti, l'Acquirente dovrà immediatamente: (i) verificare le quantità (n. colli/cartoni), l'integrità del materiale e del sigillo adesivo SIGMA e l'imballaggio dei Prodotti e registrare qualsiasi obiezione nella nota di consegna con il contestuale scatto di fotografie e di inviarsi qualunque indicazione in merito al danno/anomalia risultante, dentro e fuori i cartoni; (ii) effettuare un controllo di conformità dei Prodotti rispetto a quanto indicato nella conferma d'ordine e registrare qualsiasi difformità nella nota di consegna. Qualora l'Acquirente contesta la congruità di uno dei prodotti consegnati, è fatto obbligo di darne avviso scritto; contrariamente tale elemento è considerato accettato.

(c) Nel caso di denuncia di vizi l'Acquirente deve rispettare le procedure e i termini che seguono: (i) i vizi e/o difetti di qualità della merce devono essere denunciati tassativamente per iscritto dal compratore entro giorni 8 (otto) ai sensi dell'art. 1495 c.c. a partire dalla presa in consegna dei Prodotti da parte dell'Acquirente; (ii) la comunicazione dettagliata deve essere inoltrata in forma scritta al Venditore entro i termini sopra indicati. Qualsiasi comunicazione effettuata telefonicamente non viene accettata; (iii) la comunicazione deve chiaramente specificare la tipologia e l'ammontare dei vizi addotti; (iv) l'Acquirente acconsente a mettere a disposizione i Prodotti contestati perché vengano ispezionati; tale ispezione verrà effettuata dal Venditore o da un perito nominato dal Venditore.

(d) Nessuna contestazione con riferimento alle quantità, alla qualità, alla tipologia e all'imballaggio dei Prodotti potrà essere effettuata salvo che attraverso la comunicazione apposta alla nota di consegna, conformemente alla procedura sopra indicata; Qualsiasi Prodotto per il quale non sia stata sollevata alcuna contestazione conformemente alle procedure e ai termini qui sopra indicati viene considerato approvato e accettato dall'Acquirente.

(e) La sostituzione o riparazione deve essere preventivamente autorizzata per iscritto e sarà effettuata a

condizione che il reso ci pervenga in porto franco (spese di trasporto a carico dell'acquirente) con regolare documento di trasporto. Al reclamo deve essere allegata in copia la fattura di acquisto. In caso contrario sarà respinta. I prodotti di cui è stata accettata la restituzione/riparazione (anche in garanzia) saranno accreditati per intero con una riduzione minima del 15% rispetto al loro valore di fatturazione e con una ulteriore riduzione per eventuali spese di riconfezionamento e saranno riconsegnati come stabilito al punto 4.(a)

(f) I reclami relativi a fatture ed estratti conto devono essere inviati per iscritto al venditore entro 15 giorni dalla rispettiva data di emissione.

6. Controllo qualità e Termini di Garanzia. (a) Il controllo qualità del Venditore è molto accurato ed è segnalato sui listini e sui cataloghi da una piccola immagine circolare di colore rosso con scritto "Qualità Controllata".

(b) Tutti i prodotti sono coperti da Garanzia secondo le norme Italiane vigenti; In taluni casi la garanzia standard è aumentata ad anni 3 o 5 e l'indicazione è sull'immagine di cui sopra. La garanzia comprende la sostituzione di tutte le parti o componenti danneggiati e necessari al ripristino della funzionalità originale. Non sono comprese nella garanzia: (i) danni causati dal trasporto; (ii) modifiche tecniche apportate dal cliente (iii) danni causati da errata installazione o uso improprio. La garanzia non comprende inoltre la manodopera necessaria per la sostituzione dei materiali, le spese di trasferte o per trasporti.

(c) Non è ammesso nessun rimborso per spese accessorie sostenute o altre spese.

(d) Per i dettagli si rimanda a quanto contenuto nelle documentazioni tecniche "Istruzioni d'uso" SIGMA, disponibili sul sito [www.sigmailta.com](http://www.sigmailta.com) che, con il conferimento dell'ordine, il compratore dichiara di conoscere e di accettare e che, in ogni caso, devono considerarsi parte integrante delle presenti condizioni generali.

7. Limitazione della Responsabilità. (a) Tranne che nei casi di giustificata contestazione sollevati conformemente a quanto previsto nel precedente paragrafo 5, all'Acquirente non è riconosciuto alcun ulteriore diritto o rimedio. In particolare, il Venditore non è responsabile per alcun indennizzo richiesto per violazione o inadempimento contrattuale, per qualsiasi danno diretto o perdita di profitto sopportato dall'Acquirente in conseguenza dell'uso, del mancato uso, o dell'installazione dei Prodotti in altri prodotti, ad eccezione dei casi coperti da garanzia indicati nel paragrafo 6 o in caso di dolo o colpa grave da parte del Venditore

(b) Il Venditore farà tutto quanto in suo potere per consegnare i Prodotti entro i termini eventualmente concordati, ma in nessun caso potrà essere chiamato a rispondere dei danni direttamente o indirettamente causati dalla ritardata esecuzione di un contratto o dalla ritardata consegna dei Prodotti.

(c) Cataloghi, listini prezzi, materiali, qualità, colori e altri dati figurativi, prospetti, circolari o altro materiale promozionale del Venditore costituiscono soltanto una indicazione della tipologia dei Prodotti e dei prezzi e le indicazioni ivi indicate non sono vincolanti per il Venditore e non costituiscono oggetto di garanzia ai sensi dell'art. 1497 c.c.. Il Venditore non si assume alcuna responsabilità per errori/omissioni contenute nei propri listini prezzi o nel materiale promozionale.

8. Imballaggi. (a) Gli imballaggi di qualunque genere non vengono ritirati da parte del venditore e l'Acquirente si farà carico dello smaltimento nel rispetto delle norme del proprio paese a proprie spese e senza addebiti o richieste di rimborsi a qualunque titolo.

9. Riserva di Proprietà. (a) I Prodotti forniti rimangono di piena proprietà del Venditore fino alla data in cui l'Acquirente non abbia provveduto al pagamento dell'intero prezzo e di tutte le somme dovute al Venditore. Fino a tale momento l'Acquirente conserva i prodotti in qualità di possessore fiduciario del Venditore e deve custodire i Prodotti adeguatamente immagazzinati, protetti e assicurati.

(b) Nel caso in cui nel paese in cui l'Acquirente ha il proprio domicilio per la validità della riserva di proprietà a favore del Venditore sia necessario l'espletamento di formalità amministrative o legali quali, senza alcuna limitazione, la registrazione dei Prodotti in pubblici registri, ovvero l'apposizione sugli stessi di appositi sigilli, l'Acquirente si impegna fin d'ora a collaborare con il Venditore e a porre in essere tutti gli atti necessari al fine di far ottenere a quest'ultimo un valido diritto con riferimento alla riserva di proprietà.

10. Proprietà intellettuale e industriale. (a) Il Cliente riconosce espressamente che i marchi, nomi di commercio o altri segni distintivi apposti sulla merce sono di esclusiva proprietà di "SIGMA snc" e non possono essere alterati, modificati, rimossi o cancellati in qualsiasi modo. Il Cliente ha il limitato diritto di uso dei marchi, nomi di commercio o altri segni distintivi, così come di ogni altro diritto di privativa industriale o know-how produttivo e commerciale incorporato nella merce e che rimane di proprietà esclusiva di "SIGMA snc", al solo e limitato fine di rivendere la merce al pubblico. Ogni diverso utilizzo della proprietà intellettuale di "SIGMA snc" da parte del Cliente, se non espressamente concesso da "SIGMA snc" per iscritto, si intenderà violazione da parte del Cliente dei predetti diritti esclusivi, anche sotto il profilo della responsabilità contrattuale e, come tale, sarà propriamente perseguito. I documenti, disegni, video, audio, dati/informazioni (sia cartacei che su supporto elettronico) che dovessero venire consegnati al Cliente, rimangono di esclusiva proprietà di "SIGMA snc" e costituiscono supporto per una migliore rappresentazione del Prodotto e sono indicativi delle prestazioni del Prodotto stesso.

(c) I diritti d'autore e altri lavori creativi o descrizioni anche tecniche derivanti dallo sviluppo sul materiale di marketing di qualunque genere, e da chiunque realizzati fatti, apparterranno a "Sigma snc" insieme con tutti i diritti di design e tutti gli altri diritti di proprietà intellettuale esistenti in tutto il mondo e/o associato ai prodotti (d) Non è assolutamente consentito l'uso del materiale protetto da Copyright qui menzionato per la vendita online, per la quale va tassativamente richiesto il rilascio di un'autorizzazione scritta la quale va fatta pervenire direttamente al Venditore.

(e) Il Cliente si impegna a non riprodurli, a non divulgarli a terzi e ad assumerne altresì le opportune cautele nei confronti del proprio personale al fine di garantirne la tutela.

11. Trattamento dei Dati Personali. (a) I dati personali dell'Acquirente saranno trattati secondo quanto disposto dalla legge italiana ai sensi del D.Lgs. 196/2003 e dell'art. 13 Reg. UE 2016/679 "GDPR". Il Venditore informa l'Acquirente che il Venditore è il titolare del trattamento e che i dati personali dell'Acquirente vengono raccolti e trattati esclusivamente per l'esecuzione del presente accordo. L'Acquirente ha il diritto di richiedere al Venditore l'aggiornamento, la rettifica, l'integrazione, la cancellazione e la trasformazione in forma anonima dei propri dati.

12. Legge Applicabile e Foro competente. (a) Qualsivoglia controversia di natura contrattuale o extracontrattuale relativa all'interpretazione, validità, efficacia, esecuzione, risoluzione del presente, saranno soggette in via esclusiva alla competenza dell'Autorità Giudiziaria Italiana, foro di Rimini o altro deciso dal venditore; Qualora l'Acquirente sia un soggetto di nazionalità diversa da quella italiana, le presenti Condizioni e tutti i contratti stipulati da quest'ultimo con il Venditore s'intendono regolati dalla Convenzione di Vienna del 1980 relativa ai Contratti di Vendita Internazionale di Beni.

13. Disposizioni Finali. (a) L'invalibilità in tutto o in parte di singole disposizioni delle presenti Condizioni non inficia la validità delle restanti previsioni. Le presenti Condizioni sono redatte in lingua italiana e inglese. In caso sorgessero dubbi interpretativi prevarrà la versione in italiano. Ai sensi e per gli effetti degli artt. 1341-1342 c.c., l'Acquirente approva specificatamente tutte le disposizioni di cui sopra.

## Conditions of sale

## Bedingungen des Verkaufs

CONDITIONS OF SALE valid from 16 09 2018

1. General Provisions. The terms and conditions set out below shall form part of all the agreements executed between the Seller "Sigma di Evaristo Ambrogiani & C. Snc" and the Buyer for the supply of the Seller products. The General Terms and Conditions of Sale shall apply to all transaction executed between the Seller and the Buyer without any need of express reference thereto or agreement thereon at the conclusion of such transaction. Any dissenting terms and conditions shall only apply if confirmed in writing by the Seller. The Seller reserves the right to change, integrate or vary the General Terms and Conditions of Sale, by including such variations in the quotations or in any other written correspondence sent to the Buyer.

2. Offers and Orders. (a) The Seller's offers shall not be binding, in particular with reference to quantities, price and delivery time. The order confirmations waiting for instructions and/or answer from the Buyer, have validity 15 (fifteen) days after its submission.

(b) Orders placed by the Buyer shall not be regarded as accepted before these have been confirmed by the Seller in writing. If the Seller should fail to confirm an agreement in writing which it has entered into verbally, the Seller's invoice or the execution of the order by the Seller shall be regarded as confirmation.

(c) Orders must contain the articles code deduced from the price list or catalog. In the case the same order will be processed more times and/or from different canal, it must state the writing "order already transmitted". If the order is sent twice due to these reasons, the cost of the return is at Buyer charge.

(d) Orders and/or amendments of orders placed verbally or by telephone, must be confirmed in writing by the Buyer. Otherwise the Seller does not accept any responsibility for errors or consequent misunderstandings.

(e) Orders not exceeding euro 50,00 shall be charged an additional administration fee of euro 5,00. Orders not exceeding euro 150,00 shall be Prepaid.

3. Prices and Terms of Payment. (a) The Prices of the Products shall exclude any statutory VAT which shall be payable at the date of delivery or pursuant specific provisions included in the invoice.

(b) Taxes, duties, shipping, are not included in the prices unless but separately quoted.

(c) In addition to other remedies permitted under the applicable law and these General Terms and Conditions of Sale, the Seller reserves the right to recover default interest on delayed payments starting from the due date, calculated at the official reference rate of the European Central Bank increased by 7 (seven) basis points. (Dir. 2000/35/CE - D.Lgs. 231 of 09/10/2002) and refund for any consequential expenses incurred by Seller due to delayed and/or withheld payment.

(d) If the Buyer fails to take payments in the time and manner specified by the Seller or the Buyer business shall be operated beyond the ordinary course of business which shall include, without limitation, when seizure or protest has been made, payments shall be delayed or insolvency proceedings shall have been petitioned or opened, the Seller shall have the right to suspend or cancel, at its sole discretion, further delivery and to declare all its claims arising from the business relationship as immediately payable. Moreover the Seller may in such event request for anticipation on the payments or a warranty deposit. The Buyer is liable for any outstanding bills.

(e) The Buyer shall have no right to make any rounding, compensation, retention or reduction unless the counterclaims have been conclusively determined by the court.

4. Terms of Delivery. (a) Unless otherwise agreed in writing, the goods is delivered EXW (2010 INCO-TERMS), by a means selected from the Buyer.

(b) Unless otherwise expressly agreed in writing any indicated time of availability shall be nonbinding for the Seller. Unless different agreement between the parties, the approximate term for the availability is the one specified in the confirmation of order.

(c) Unless otherwise agreed in writing by the Buyer, Seller reserves the right to process partial deliveries and the Buyer accepts the consignment and will pay the goods delivered; the delivery will be made according to point 4.(a).

(d) If, for any event of force majeure or in any case of excessive intervening, or due unforeseen difficulties outside the Seller responsibility including, without limitation, strike, lock out, acts of public authorities, subsequent cease of export or import opportunities shall, for their duration and in accordance with their impact, the obligations of the Seller has become temporarily impossible or prohibitively expensive -before their execution- the Seller may request a review of the contractual conditions and, is failing, declare the contract terminated without any burden for the seller an relieve him from the obligation to comply with any agreed time for delivery.

(e) The Seller is not obliged to accept the Products returns, unless otherwise agreed in writing. Any costs arising thereof shall be at the expense of the Buyer.

5. Duty to Inspection and Acceptance of Products. (a) Whatever the yield, the goods travel at the risk of the Buyer, therefore every complaint must be addressed directly to the carrier and declared on the delivery document before signing the receipt. Not liable for any lack of conformity resulting from crushing or products scratches, caused by transport and handling.

(b) Upon taking possession of the Products, the Buyer shall immediately: (i) check quantities (numbers of the boxes), the integrity of the material and the SIGMA adhesive seal and to photograph and send us any damage/anomaly, inside and outside the boxes; (ii) conduct a conformity check on the Products compared to the data indicated in the confirmation of order and record any objections on the delivery note.

So far as the Buyer disputes the appropriateness of one of the delivered products, it is obligatory to give written notice; on the contrary this element is considered accepted.

(c) In case of a notice of defect the Buyer shall comply with the following procedures and deadline: (i) Faults and defects in the quality of goods shall be reported in writing by the purchaser in compliance with art. 1495 of the Italian c.c. and in any case within 8 (eight) days from the taking possession of the Products by the Buyer; (ii) the detailed notice above mentioned shall be delivered in written form to the Seller within the deadlines. Any notice by telephone conversation shall not be accepted; (iii) the notice must clearly specify the kind and amount of the alleged defect; (iv) the Buyer agrees to make available for inspection the objected Products; such inspection shall be done by the Seller or by any expert designated by the Seller.

(d) No objections with regard to the quantities, quality, type, and packaging of the Products shall be possible unless a note has been placed on the delivery note in accordance with the above mentioned procedure. Any Product to which objection shall not have been raised in accordance with the procedures and deadlines set out above shall be regarded as approved and accepted by the Buyer.

(e) Replacement or repair previously authorized in writing and will be made on condition that the return is received "carriage paid" (cost of the transport charged to Buyer), with regular transport document. Copy of purchase invoice must be attached. Otherwise it will be rejected. Products whose return has been accepted are credited in full, with a minimum reduction of a 15% compared to its invoiced value

and a reduction for any costs for repackaging and shall be returned as established in point 4.(a).

(f) Claims concerning invoices and account statements shall be sent in writing to Seller within 15 days from the date of issue.

6. Quality check and terms of Warranty. (a) Quality control of the Seller very accurate and is reported on the price list and on the catalog by a small round red image eith writing "qualità controllata".

(b) All the products are covered by warranty in accordance with Italian law; in some cases the standard warranty is increased to 3 or 5 years, and the indication is on the image above. Warranty includes replacement of all damaged parts or components necessary to restore the original functionality. Are not under warranty: (i) damage due to transport; (ii) technical changes made by customer; (iii) damages due to wrong installation or improper use. Warranty does not include the labor required to replacement, travel or transports.

(c) No refund is allowed for incidentals incurred or other expenses.

(d) For details refer to the content of the SIGMA technical documentation "Istruzioni d'uso" available on the website [www.sigmailta.com](http://www.sigmailta.com) that, with the confirmation of the order, the Buyer declares to know and accept, and that, in any case, shall be considered an integral part of these general terms and conditions.

7. Limitation of Liability. (a) Unless in case of justified objection which shall have been raised in accordance with the procedure and deadlines set forth in paragraph 5 above, the Buyer shall not be entitled to any further rights or remedies. In particular, the Seller shall not be responsible for any compensation based on breach of contract or default, for any direct or indirect damage or loss of profit due to the use, the inability to use, or the incorporation of the Products in other products, unless under warranties granted in paragraph 6 or in cases of willful misconduct or gross negligence on the Seller's part. (b) The Seller shall do its best endeavor to deliver the Products within the time agreed (if any), but it shall not be liable for any loss or damage of any kind whatsoever caused directly or indirectly by any delay in the completion of the contract or delivery of the Products.

(c) Catalogues, price lists, quality, materials, colours and any other figuratives data in catalogs, prospectuses, circulars, or other matters of the Seller are only an indication of the type of Products and no prices or other information contained herein shall be binding for the Seller and not covered under warranty under art. 1497 c.c.. The Seller does not accept any responsibility for errors/omissions contained in its price lists or promotional matters.

8. Packaging. (a) Any kind of packages are not collected from the Seller and the Buyer is responsible for disposal in accordance with the rules of his Country at his own expense and without objections or requests for refunds for any reason.

9. Retention of Title. (a) The Product supplied shall remain in the property of the Seller until the date of the full payment by the Buyer of the entire price of the Products and of all amounts due to the Seller. Until that time the Buyer shall hold the Products as the Seller's fiduciary agent and shall keep the Product properly stored, protected and insured.

(b) If in the Country of the Buyer's domicile for the validity of the retention of title for the benefit of the Seller it is necessary to fulfil some administrative or legal formalities as, without limitation, to file the Products with the public registers or to affix particular seals on them, the Buyer shall cooperate with the Seller and shall do its best effort for carry out all the necessary actions in order to obtain a valid retention of title right on the Products for the benefit of the seller.

10. Industrial and Intellectual Property. (a) The Client expressly recognizes that trademarks, commercial names or other distinctive marks on the goods are in the exclusive property of the "SIGMA snc" and will not be altered, changed, removed or cancelled in any manner. The Client has the limited right to use trademarks, commercial names or other distinctive marks, as well as other industrial exclusive right or Know how (productive or commercial) associated with the goods - which nonetheless remain in the exclusive property of "SIGMA snc" - to the limited purpose of the resale of the goods to the final consumer.

Any other utilization of the "SIGMA snc" Intellectual Property by the Client, if not expressly granted by "SIGMA snc" in writing, will be considered an infringement of the exclusive rights of "SIGMA snc", and a breach of contract, and will be therefore prosecuted.

(b) The documents, drawings, videos, audios, data and information (both in written papers and on electronic support) which should be delivered to the Client, remain exclusive property of "SIGMA snc" and constitute a support for a better representation of the product and are significant of the general performances of the product itself.

(c) The copyright in all photographs designs and other creative works technical descriptions generated in the development on any marketing material relating to the goods (made by anyone), shall belong to "SIGMA snc" together with all design rights and all other existing Intellectual Property rights anywhere in the world and/or associated with the Products.

(d) It is absolutely not allowed to use the copyrighted material mentioned here for the online sale, for which it is strongly required to issue a written authorization sent directly to the Seller.

(e) The Client engages itself not to reproduce them, neither to disclose them to a third party, and he engages himself to undertake the proper precaution towards staff in order to grant the above protection.

11. Data Protection Law. (a) The personal data of the Buyer shall be processed in accordance with the Italian data protection law D.Lgs. 196/2003 e dell'art. 13 Reg. UE 2016/679 "GDPR". The Seller inform the Buyer that the Seller is the data controller and that the Buyer's personal data shall be collected and processed for the only purpose of the performance of this agreement. Pursuant article 7 of the Italian Legislative Decree 196/2003, the Buyer has the right to ask to the Seller the updating, amendment, integration, writing off and transformation in anonymous form of its data.

12. Jurisdiction. (a) Any dispute related on in any way connected to the interpretation, execution or termination of the contracts these general conditions apply to, shall be solely resolved before the Tribunal Court of Rimini or other indicated by the Seller. If the Buyer is nationality other than Italian, these Terms and all contracts entered into by the latter with the Seller are governed by the 1980 Vienna Convention relating to Contracts for the International Sale of Goods.

13. Final Provisions. (a) The total or partial invalidity of any provision of the present General Terms and Conditions of Sale shall not affect the validity of the other provisions.

(b) The present General Terms and Conditions of Sale have been drafted in both Italian and English languages. In case of problems of interpretation the Italian version shall prevail. Pursuant articles 1341 e 1342 of the Italian Civil Code the Buyer hereby specifically accepts the following provisions above.



**sigma** di Sergio Ambrogiani & c. s.a.s.

Via Gagliani,4

47814 Bellaria Igea Marina (RN) Italia

Tel. +39 0541 330103

C.F.-P.I.-ID code: IT 01085360400

Fatt.Elettr.: mj1oynu

E-Mail: [info@sigmaitalia.com](mailto:info@sigmaitalia.com)

Internet: <https://www.sigmaitalia.com>